



**Systematically Understanding the Cyber Attack Business:
A Survey**

Keman Huang, Michael Siegel, and Stuart Madnick

Working Paper CISL# 2018-08

July 2018

Cybersecurity Interdisciplinary Systems Laboratory (CISL)
Sloan School of Management, Room E62-422
Massachusetts Institute of Technology
Cambridge, MA 02142

Systematically Understanding the Cyber Attack Business: A Survey

KEMAN HUANG, MICHAEL SIEGEL, and STUART MADNICK,

Massachusetts Institute of Technology

Cyber attacks are increasingly menacing businesses. Based on the literature review and publicly available reports, this article conducts an extensive and consistent survey of the services used by the cybercrime business, organized using the value chain perspective, to understand cyber attack in a systematic way. Understanding the specialization, commercialization, and cooperation for cyber attacks helps us to identify 24 key value-added activities and their relations. These can be offered “as a service” for use in a cyber attack. This framework helps to understand the cybercriminal service ecosystem and hacking innovations. Finally, a few examples are provided showing how this framework can help to build a more cyber immune system, like targeting cybercrime control-points and assigning defense responsibilities to encourage collaboration.

CCS Concepts: • **Social and professional topics** → **Computing and business; Socio-technical systems; Computer crime**; • **Security and privacy** → **Social aspects of security and privacy; Systems security; Social network security and privacy**;

Additional Key Words and Phrases: Cyber attack business, cyber crime, value chain model, cyber-crime-as-a-service, hacking innovation, control point, sharing responsibility

ACM Reference format:

Keman Huang, Michael Siegel, and Stuart Madnick. 2018. Systematically Understanding the Cyber Attack Business: A Survey. *ACM Comput. Surv.* 51, 4, Article 70 (July 2018), 36 pages.

<https://doi.org/10.1145/3199674>

1 INTRODUCTION

“Where there is commerce, there is also the risk for cybercrime” [131].

Cybercrime is a tremendous threat to today’s digital society. It is estimated that the cost of cybercrime will grow from an annual sum of \$3 trillion in 2015 to \$6 trillion by the year 2021 [109]. Nearly one-third of companies are affected by cybercrime (32%). Indeed, 61% of CEOs are concerned with the state of the cyber security of their company [124]. It has become generally accepted that, “there are only two types of companies: those that have been hacked and those that

This work is partially supported by the National Natural Science Foundation of China under grant 61502333, and Cybersecurity at MIT Sloan (the MIT Interdisciplinary Consortium for Improving Critical Infrastructure Cybersecurity, MIT-(IC)³). Authors’ addresses: K. Huang, Sloan School of Management, MIT, Cambridge, MA 02142, USA; email: keman@mit.edu; M. Siegel, Sloan School of Management, MIT, Cambridge, MA 02142, USA; email: msiegel@mit.edu; S. Madnick, Sloan School of Management, School of Engineering, MIT, Cambridge, MA 02142, USA; email: smadnick@mit.edu.

Permission to make digital or hard copies of all or part of this work for personal or classroom use is granted without fee provided that copies are not made or distributed for profit or commercial advantage and that copies bear this notice and the full citation on the first page. Copyrights for components of this work owned by others than the author(s) must be honored. Abstracting with credit is permitted. To copy otherwise, or republish, to post on servers or to redistribute to lists, requires prior specific permission and/or a fee. Request permissions from permissions@acm.org.

2018 Copyright is held by the owner/author(s). Publication rights licensed to ACM.

ACM 0360-0300/2018/07-ART70 \$15.00

<https://doi.org/10.1145/3199674>

will be” [110]. Fighting an impending cyber attack has become an important issue for companies in all industries and governments, especially those relying heavily on information technologies.

Ever since the first reported cybercrime in 1973, when Union Dime Savings Bank account data was manipulated, cybercrime has been continually evolving.¹ Beyond a nefarious hobby, cybercrime has become a way for cybercriminals to earn a living.² While it remains underground, it is a business nonetheless; attackers cooperate and work to maximize profits and minimize risk of arrest [81]. Cybercrime as a profession is increasingly attractive for able hackers, and in turn, cyber attacks themselves are increasingly well organized [2]. With the wide-spread adoption of the “as-a-service” model for cyber attack, the attacker can purchase the desired “service” through the dark web without so much as a cursory understanding of what is involved in its execution [97, 134, 145]. This eliminates the barriers that previously existed to performing a crippling cyber attack, and pushes the attackers deeper underground and further from the grasp of authorities.

In the words of Sun Tzu, “Know yourself, know the enemy” [165]. To combat cybercrimes in an effective way, we not only need to develop technical solutions to protect against attacks but also need to understand the structure of the business of underground cybercrime and its development:

- **The Challenge in Understanding Cyber Attack Operations**

It has been said that “the good guys are getting better, but the bad guys are getting badder faster” [93]. Much of published research on cyber attacks has been focused on how attackers clandestinely intrude on private systems [3, 60, 66, 129, 157]. However, reacting passively to a cyber attack and attempting to keep up with the almost daily emergence of innovations on behalf of cybercriminals means that “[Corporations] are not winning [in the cyberdefense battle]” [102]. Cybercrime has taken on the guise of a business in recent years. Without understanding the relevant operations of cybercrime, it is difficult to combat cybercrime effectively. Researchers have begun to study different components of this underground business, including the marketplaces connecting attackers and buyers, and the community of hackers ready to deliver services for a fee [16, 18, 59, 67, 70, 86, 87, 90, 117, 126, 129, 147, 154, 160, 174]. Based on these individual elements, Thomas et al. [162] proposes a framework for understanding the structure of the underground cybercrime service through the monetization process, offering what can be characterized as a bird’s-eye view of the black market for cybercrime. What remains unclear, however, is how the cybercriminal coordinates a cyber attack, and making sense of innovations in hacking. “Cybersecurity is still a game of cat-and-mouse” [41], with the defense trying to catch up with the offense with, up until this point, little success to show for its efforts.

- **The Challenge in Understanding the Cyber Attack Economy**

The underground cybercriminal has proven difficult to study. Researchers have used “honeypots” [112] to identify cybercriminals and have collected information on the activities of cybercriminals [147]. These efforts to monitor the development of cyber attacks offer relevant counter intelligence. In considering the adoption of the “as-a-service” model [50, 131, 145, 162], researchers have compiled the services offered to buyers by the cybercrime industry. However, these services are widely scattered and inconsistently described. Without a clear framework through which to

¹There is still much debate about the definition of cybercrime and what constitutes a cyber attack. Since no single, agreed-upon definition exists, in this article we will consider all cyber activities that are related to a “cyber attack” or that which undermines the function of the digital system belonging to the cybercriminal ecosystem. Note that not all activities included in our model are illegal. In fact, there are many discussions, which are outside the scope of this article, about cyber ethics and the legality of such activity [58, 149].

²During 2015, the CryptoWall ransomware virus raised more than \$325 million for the hacking group. Please check <http://thehackernews.com/2015/10/cryptowall-ransomware.html> for details.

study the cybercrime service economy, it remains difficult to understand the modern cyber attack effectively.

- **The Need to Gather Information about these Diverse Services and Provide a Framework to Systematically Understand the Cyber Attack Business**

The goal of this article is to develop an extensive and consistent survey based on a literature review and publicly available reports, organized using a value chain framework, to help understand cyber attacks in a systematic way. This can also help to develop more effective defense strategies. Cybercriminals run a business of selling cyber attacks, thus we concentrate on what could be considered as the “value-added” processes for cyber attacks. To understand these processes, we develop the *cybercriminal value chain model* consisting of the primary activities of vulnerability discovery, exploitation development, exploitation delivery, and attack, as well as the supporting roles of cyber attack life-cycle operations, human resources, marketing and delivery, and technical support. It is important to note that both the defensive side (cybersecurity) and offensive side (cybercrime)³ of cyberspace use similar innovations [37] and that not all activities included in the value chain model describing cybercrime are definitively illegal. For example, vulnerability discovery and disclosure are what are called “double-sword” activities. While they can be used to develop patches for a flawed system, they can also represent techniques to identify opportunities for deliberate exploitation by criminals [4, 9, 70].

In addition, we develop the service model—consisting of input, output, and support—to systematically discuss the cybercrime ecosystem, considering its restructuring into an “as-a-service” model. This enables the *specialization*—cyber attackers can focus on specific components and promote the expertise level; *commercialization*—cyber attackers can monetize their attack expertise; and *cooperation*—cyber attackers can loosely or closely collaborate with each other to do complex attacks, in the cybercriminal ecosystem. Using the presented value chain model, we survey how diverse cybercrime activities can be executed in a service style, resulting in a cybercrime ecosystem framework to systematically understand the cyber attack business.

This framework enables us to systematically understand hacking innovations, which can help to redefine the cat-and-mouse game [41]. By following the “value-added” paths in the framework, we can understand the development, including availability and pricing models, of the cybercriminal services. The Return-On-Investment (ROI) analysis reveals that cybercrime is a serious business, indicating the great value that “cybercriminal service composition as a service” represents to the cybercrime ecosystem.

Finally, based on the presented framework, identifying control points can help to improve the effectiveness with which cyber attack evolution is monitored and the business of cybercrime can be disrupted. Delegating responsibilities and actions among involved parties based on this framework is also helpful for realigning incentives of collaboration in the fight against cybercrime.

Therefore, the main contribution of this article is the systematic survey of cybercrime services, which helps to understand the cybercrime ecosystem as a business and its evolution for further designing more effective intervention strategies. In Section 2, we present the value chain model for understanding cybercrime activities. Section 3 introduces the service model and details the cybercriminal services. Section 4 reports the developed ecosystem framework to study the cyber attack business reconstruction and its evolution, including the emergence of the “cybercriminal service composition as a service.” Section 5 summarizes this article and briefly highlights possible ways to combat cyber attacks using the cybercriminal service ecosystem framework.

³There are two sides to cyberspace: the defensive side focuses on improving cyber security and protecting the targets from attack, while the offensive side is for cybercrime and trying to attack the targets. In this article, for the offensive side, we will use hackers and attackers synonymously.

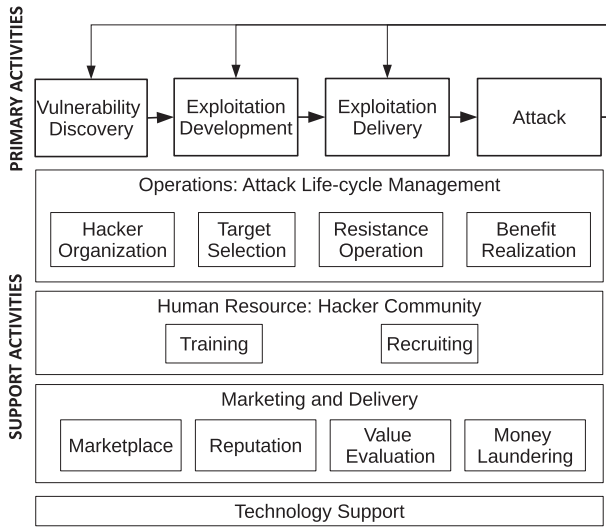

Fig. 1. Cybercriminal Value Chain Model.

2 CYBER ATTACK ACTIVITIES: THE VALUE CHAIN MODEL

To effectively combat cyber attacks and enhance the cybersecurity on which our digital society relies, it is important to understand the operations behind a cyber attack, raising the following questions: *What activities are associated with a cyber attack?* The value chain model, developed by Michael Porter [122], is a powerful approach to understanding the value-added procedures embedded within an organization. The value chain model views an organization as a system, made up of subsystems each with inputs, transformation processes, and outputs, along with support activities. As cybercrime has become a business, from a value chain perspective, we can identify activities that add value for cyber attack operations, as presented in Figure 1. These value-added processes include *any activity in the cybercrime business ecosystem that helps the attacker reduce the cost of, and increase the benefit incurred in cyber attacks*. Straightforwardly, the primary activities that directly involve the attack are valuable for the attackers. The support activities, which are often overlooked, are also critical in facilitating the operation of the cybercrime business, as they can help the attacker to perform an attack with less cost and for higher benefit. Furthermore, we have validated the list of cybercrime services and this value chain framework, as well as the cybercriminal service ecosystem framework in Section 3, with more than 30 senior executives, managers, and researchers focusing on cybersecurity from Fortune 500 companies and key cybersecurity solution providers to improve the framework.⁴ To the best of our knowledge, this is the first comprehensive survey, which integrates the different components of the cyber attacks and uses value-chain model, to systematically understand cyber attacks from the business perspective.

2.1 Primary Activities: The Attack

2.1.1 Vulnerability Discovery. Logically speaking, cyber attacks start with vulnerability discovery, which finds the weakness that can be used to intrude into the victim's systems. This

⁴These senior managers and executives are from members of Cybersecurity at MIT Sloan. Please check <https://ic3.mit.edu/> for the member list. In addition, we use WannaCry attack as an example to show the efficiency of this framework in understanding a specific cyber attack. Due to the space limitation, please check Section F in Support Materials for more details.

weakness may be a zero-day/one-day vulnerability in software/hardware, or the relatively simple use of passwords that are not modified for a long time and easy to uncover by brute force [106]. Cybersecurity usually involves technology, people, and process [89]. Overlooking strategic, managerial, and operational issues related to cybersecurity significantly weakens an organization's defenses against cybercrime [94]. Hence, vulnerability refers to both weaknesses in software or hardware in IT/OT systems, and weaknesses found in processes, policy, and the human component of an organization.

Definition 1. Cyber Vulnerability refers to the cyber-related weaknesses that can be used by a cyber attacker to intrude into the organizations, including the weakness in software or hardware, named technical vulnerability V_t , and the weakness in the process, policy, and human, named operational vulnerability V_p .

Based on this definition, the vulnerabilities detailed in vulnerability databases like National Vulnerability Database (NVD) and Security Focus BID [70] are considered as technical vulnerabilities in IT/OT systems. Most current vulnerability discovery research focuses heavily on the technical vulnerabilities [24, 55, 143]. However, with the development of defensive technologies, it becomes more difficult for an attacker to intrude into a target's systems through only software or hardware vulnerabilities. This means that an organization's vulnerabilities related to process, policy, and human aspects are often the "weakest link" in their security schemas and present themselves as opportunities for cybercriminals [135]. The typical cyber attack targeting these weakest links is the social engineering attack that deceives the users in an organization [161]. Furthermore, cyber threats from the supply chain are increasing [140]. Some recent efforts have attempted to detect and understand operational vulnerabilities in process and policy [113]. For example, a causal analysis based on STAMP [133] identified the presence of damning operational vulnerabilities that were exploited by hackers and cost TJX over \$170 million in losses in the 2007 TJX data breach incident.

2.1.2 Exploitation Development. The "Exploitation Development" activities try to exploit the discovered vulnerabilities, including both technical and operational vulnerabilities. Once a technical vulnerability is discovered, a program can be developed to exploit the vulnerability and force a system to behave in unintended ways so that a cybercriminal can carry out actions that would otherwise not be permitted. To increase the chances of success of an attack, multiple vulnerabilities may be targeted as a part of an "exploit kit." For example, the well-known exploit kits, such as Angler, Magnitude, Neutrino, Nuclear, RIG, and so on, are continually updated to reliably exploit technical vulnerabilities and guarantee continued success in disrupting the normal function of the targeted system [31]. Furthermore, a payload [18, 139] could be a malicious program performing a singular function, or a combination of many independent programs to offer a more complex, comprehensive functionality, which can be used to perform malicious actions.

Additionally, to perform advanced attacks by exploiting an operational vulnerability, some social engineering toolkits have been developed.⁵ The Social Engineer Toolkit (SET) [121] was specifically designed for targeted attacks against a person or organization in a penetration test. Many social engineering exploits begin with the manipulation of the user-computer interface to breach a computer system's security [60]. For example, developing fake mobile apps that appear to be the same as their legitimate counterparts is one typical cyber attack to exploit the operational vulnerability that arises from what we consider the human factor of an organization [42]. The business email compromise scams [98], also known as "CEO fraud" or "whaling phishing," is another

⁵Note that some social engineer toolkits may not be developed for cyber attacks but for penetration tests. However, due to the neutrality of the toolkits, they can also be used by black hat hackers to perform cyber attacks.

example in which the attacker counterfeits a message from a senior executive to trick someone at the organization into wiring funds to them. The operational vulnerability in the organization's financial process and human component is exploited to develop a persuasive, but fake, message.

2.1.3 Exploitation Delivery. Once vulnerabilities are ripe for exploitation, the cybercriminal must deliver the developed exploitative programs to the victim's cyberspace niche. Based on the delivery medium (physical medium or digital channel) and infected approach (whether it needs an intermediate host or not; if yes, whether the host is an individual server or a distribution channel), there exist four typical delivery mechanisms:

- **Physical Infection.** This straightforward mechanism involves infecting the victim's system via a physical medium, such as hardware or USB; the delivery depends entirely upon physical transportation. The typical observed scenario is that this mechanism uses virus propagation: once one person with an infected system makes copies of files that are then used on another system, the virus will spread to the second system, from which even more systems can be infected. Though this physical infection mechanism is old-fashioned and ultimately not very effective, due to operational vulnerabilities, it remains relevant. An example would be purposefully dropping a USB drive loaded with an exploitative program inside an organization's offices, or even in the parking lot, with the hope that an employee may pick it up and plug it into a computer, at which point the company's systems can be infected. In the supply chain security scenario, counterfeit hardware or hardware with embedded malware can be distributed to infect many victims [140].

- **Sent Directly.** This mechanism involves sending the exploitative program directly to the victim. In this scenario, the programs will be forwarded to the victim's cyberspace niche through digital channels, like SMS messages or email. Once the victim is tricked into accepting the exploitative program, such as by opening the fake emails or messages, the exploit has been successfully delivered and the victim's system will be infected. One attack utilizing this mechanism in recent memory is the Ukraine power grid cyber attack. Spear phishing emails containing BlackEnergy malware were sent to the victims, and the corporate IT network was compromised by opening disguised documents attached to the emails, which then propagated to the OT network [39].

- **Drive-by-download.** The third mechanism involves redirecting the victim online to a website loaded with the exploitative programs, which are delivered to the victim's system in a "drive-by-download." In this scenario, the victim is driven to the compromised website by following a maliciously disguised advertisement and is redirected to a landing page where a downloader for the exploitative program will be installed on the victim's machine to contact the command-and-control (C&C) server and establish at least one download channel to deliver the exploitative programs to the target's cyberspace niche [16, 130, 160].

- **Software-Distribution.** This fourth mechanism has been emerging with the rapid development of the mobile ecosystem. In this scenario, an original piece of software is infected during transmission to the user. One typical approach is to add malicious code to the software that requests permissions beyond those required by the original software through repacking [68]. Once the adulterated software runs, the malicious code will be executed and the exploitative programs will be downloaded to the victim's machine [56]. With the development of the auto-update feature, the cybercriminal can also dynamically add malicious code to an application during runtime or update an application to include malicious components so that a benign application becomes malicious after a software update [3, 125].

2.1.4 Attack Victim. Once a victim's system is successfully infected, the avenue is open for attack. For a single-step attack, once an initial action by the victim has been carried out, such as open a file, click on a link, run a program, accept a permissions request, the attack is already completed. For a multi-step attack, the initial action by the victim not only activates an immediate

attack but also opens the doors for subsequent attacks, including identifying further exploitable vulnerabilities. In this scenario, the attacker first gains privileged access to a victim's system so that they can move freely within the otherwise private environment. Once an attacker successfully intrudes upon a system, he or she can access and extract sensitive information, rewrite or erase files, and alter the functionality of the system, affecting the system's confidentiality, integrity, and availability of data. To once again use the Ukraine power grid attack [39] as an example, after disrupting the power grid, the hackers used KillDish to erase important executable files and cause physical damages to the control system. Some attackers may want to establish a sustained presence in their victims' systems so that they may come and go and do as they please. To study the cyber attack from the value-added perspective, instead of the detailed cyber attack mechanisms, we must understand what a cybercriminal can gain from a successful cyber attack and what these gains afford in terms of further attacks:

- **Digital Gains.** Once inside, an attacker can get information contained in a victim's system, including sensitive information such as personal profiles, accounts, and intellectual property. The compromised system can be a "trophy" for the attack, while sometimes the human who is tricked by the attacker can be a "trophy." One example is when someone is tricked to work as a money mule for money laundering [66]. Furthermore, the attacker can gain valuable knowledge related to the victim's system, such as operational processes, network configuration, and organizational structure. With an understanding of these aspects of a system, an attacker can better hide further attacks from detection. What made the cyber attack on Bangladesh Bank's (BB) SWIFT payments system in February, 2016 [142] so hidden and damaging was the attacker's understanding of the bank's transaction confirmation process: The attacker was able to intercept confirmation messages and cover up fraudulent transactions. Attacks to the CIA [168], NSA [54], Hacking Team [62], and so on, can offer attackers 0-day vulnerabilities, exploitations, and many tools developed and customized by these professional organizations that expand and strengthen their arsenal.

- **Direct Monetary Gains.** A successful attack can interrupt the business continuity of an organization by adversely affecting the confidentiality, integrity, and availability of certain systems. This results in not only a direct monetary cost to an organization in the form of losses or damages but also in indirect costs, such as loss of trust, missed business opportunities, and increasing defense costs for prevention, protection, detection, response, and recovery to the cyber attack [7]. The attacker can benefit by monetizing the victim's loss for themselves. The typical scenario is that the attacker draws funds directly from a victim's accounts. The more eye-catching scenario with a recent surge in popularity involves the attacker proving his or her capability to interrupt the victim's business continuity and requesting money in return for not capitalizing on their abilities, effectively holding a business hostage for a ransom. The ransomware attacks of 2016 [114] are such examples and 88% of these attacks targeted hospitals and health systems, since cybercriminals correctly perceived these organizations as more vulnerable and receptive to threats and eager to pay a ransom to avoid damage.

- **Psychological Gains.** The attacker who carries out attacks seeking the inherent satisfaction of success or for the fun or challenge of the process gains psychological benefits from an attack [81]. In this particular case, the attack is perceived as merely a test of hacking skills, and the successful attack carries with it not only a sense of accomplishment for the attacker but also reputation in the hacker community. Some attackers may seek vengeance against a symbolic enemy or see cybercrime as a way to further political agendas. Anonymous is one such group. A particular interesting case was when Anonymous attacked Freedom Hosting II, which hosts 20% of dark web websites, 50% of which contained child pornography in some forms [13]. In this case, Anonymous was trying to "do something good."

2.2 Support Activities: Facilitate the Attack

To supplement the primary activities discussed above, support activities are emerging in the cybercrime ecosystem to make cyber attacks more efficient: *gaining greater benefit with less cost*.

2.2.1 Operations: Attack Life-cycle Management. A cybercrime operation, like a legitimate business [152], must actively manage and support the cyber attack life-cycle to reduce costs, increase profits, and mitigate risk. In addition, cybercrime operations must also make conscious efforts to avoid being identified and having their operatives punished under the law. To meet these criteria, a cybercriminal within a greater operation must select the valuable attack targets, decide how to organize hackers (if more than one) to carry out primary cybercrime activities, manage the distribution of proceeds (payroll if you will), hide the operation from authorities, and if disrupted, recover the sidelined operation.⁶

Definition 2. Cyber attack Operations refers to the activities that manage and support primary activities to gain higher benefit with less cost from the cyber attack. These include target selection, hacker organization, benefit realization, and resistance operation.

- *Target Selection: what are the characteristics that make a target valuable for cyber attackers?*

The cybercriminal in the executive role selects the target that would deliver the highest profit, the greatest positive difference between benefit and cost [81]. There are three factors to consider in evaluating the benefit from a successful cyber attack:

- **Ease of the attack P_e .** If hackers do not have a specific objective, then they may take on an exploratory mindset to probe various targets and identify those with sufficient weaknesses to be considered for a full-scale cyber attack. In this scenario, the more easily vulnerabilities can be discovered and exploited in a certain organization's systems, the more attractive of a target the organization becomes. Once a specific target was selected, the cybercriminals may take on an exploitation mindset to dig into the target's systems and attempt an attack; however, if breaking into the current target's systems proves too difficult, and after a few days or weeks no progress is made, the target can be abandoned in favor of another target identified in the exploratory phase.

- **Potential Benefit B_p .** As mentioned above, a successful attack can bring the attacker the digital gains that themselves have value in the underground market, or the attacker can attempt to seek money directly from the victim of the attack. The attacker may also experience psychological gains. These encompass the two main categories with which we can understand the benefit to cybercriminals in the wake of a successful cyber attack: the monetary benefit B_{pm} and the psychological benefit B_{pp} . Hence, $B_p = B_{pm} + B_{pp}$.

- **Ease of benefit realization E_r .** Converting unrealized benefit into tangible, realized benefit is of concern to the cybercriminal engaged in the business of cybercrime. The easier it is for cybercriminals to experience the benefit earned in an attack, the more true benefit is accrued.

Hence, we define the **expected benefit B_e** for an attack on a given target as follows: $B_e = P_e \times (B_{pm} + B_{pp}) \times E_r$.

In terms of costs, we can identify the following costs inherent to the execution of an attack:

- **Psychological Costs C_{ps} .** Costs of this nature refer to the psychological and mental energy expended in committing a cyber attack. These could include the fear of being caught, or punishment.

⁶Based on the definition presented by William J. Stevenson [152], operations management is "the management of systems or processes that create goods and/or services." Operations management specialists are involved in "product and service design, process selection, selection and management of technology, design of work systems, location planning, facilities planning, and quality improvement of the organization's products and/or services."

• **Expected Penalty Costs C_p .** This cost captures to the monetary opportunity costs of conviction if the attackers, which become real if the cybercriminals happen to be arrested and convicted following the attack. Straightforwardly, it is proportional to the arrest rate P_a for the particular kind of cyber attack, the ease of the judicial process involved in the conviction P_c , and the monetary opportunity cost if the attacker is convicted C_c . $C_p = P_a \times P_c \times C_c$.

• **Operational Costs C_o** refers to the cost to carry out the cyber attack. The investment cost C_{im} captures the up-front costs for the cybercriminal to perform the attack, which could be renting a server, buying or learning any necessary tools or services, and the opportunity cost of the time taken in searching for valuable targets. The monetary opportunity cost of the investment C_{om} in cyber attack should also be considered. Hence, $C_o = C_{im} + C_{om}$.

Based on these definitions, the expected cost C_e for an attack can be defined as $C_e = C_{ps} + (P_a \times P_c \times C_c) + (C_{im} + C_{om})$.

Definition 3 (Cyber attack Target Selection Rule). For a rational cyber attacker, the target can be considered as valuable if and only if the expected benefit outweighs the expected cost:

$$P_e \times (B_{pm} + B_{pp}) \times E_r > C_{ps} + (P_a \times P_c \times C_c) + (C_{im} + C_{om}). \quad (1)$$

Note that the equations discussed above are at a high level. They can help us to understand the values of different activities for the cyber attack. Any activity that can reduce the expected cost or increase the expected benefit will be highly valuable in the cybercrime ecosystem. Understanding this operation can shed light into the decision-making process for the attackers.

- *Hacker Organization: how do cybercriminals collaborate with each other for an attack?*

For an attack to be successful, especially for the organized cyber attack that involves multiple hackers, the cybercriminal in the executive role must organize his or her team for the attack. There exist the following six basic types of organization structures [104]:

- A *Swarm* refers to a group of hackers who work together in viral forms that have a minimal, if not nonexistent, chain of command;
- A *Hub* refers to the structuring scheme in which there is a core group of hackers around which peripheral associates gather;
- A *Clustered Hybrid* structure combines online and offline activity and typically operates in a similar way as *Hub*, focusing on specific activities or methods;
- An *Extended Hybrid* structure is like the *Clustered Hybrid* structure but incorporates many associates and subgroups, while retaining a level of coordination sufficient to ensure the success of operations;
- *Hierarchies* refer to structure reminiscent of traditional organizations as well as criminal groups but take advantage of online technology to facilitate activities;
- An *Aggregate* structure refers to a loosely organized group of hackers committed only to temporary collaboration and often without a clear goal.

Different organizational structures have different pros and cons; the leaders need to consider which organizational structure is best suited to a given attack objective. For example, most state-supported cybercriminal hackers organize under a *Hierarchy* structure, while the well-known group Anonymous appears to adhere to an *Aggregate* structure. Though family ties, friendships, and online relationships all play important roles in the collaboration between cybercriminals [115], online forums are serving as offender convergence settings for cybercriminals and shaping a more fluid and flat structure so that all participants are able to get contact with each other [85]. Furthermore, in online hacker forums, most hackers are novices with only a few more highly skilled

hackers participating in forum activity [64, 87, 90], and this community forms the core and peripheral *Hubs*.

- *Benefit Realization: How to gain benefit from an attack*

It is within the executive's responsibilities to maximize the benefit to be gained from a successful attack. Considering monetary benefit as an example, the executive may hire a money laundering network so that the source of "dirty" money cannot be identified. Recently, researchers have presented the concept of "DDoSCoin," which allows a cybercriminal to prove their own participation in a DDoS attack by having miners create a large number of connections to a given target and using the target server's signed responses as a proof to receive the digital monetary rewards that they deserve [169]. Digital currency, especially Bitcoin, has become the main approach for cybercriminals to transfer monetary gains to one another in the wake of a successful attack [80]. Though the motivation for the WannaCry ransomware attack on May 2017 is still a mystery, there is a theory that it is for currency manipulation to raise the Bitcoin value by increasing the number of users [163]. Additionally, many markets or forums are constructed for cybercriminals to trade their digital gains from successful attacks [26, 123, 147, 174]. According to the tracking of ransomware payments [123], 95% of the traced ransoms are cashed out via BTC-E, a digital currency trading and exchange platform. For psychological benefit, "Hall of Fame" for hackers with the greatest reputations can motivate cybercriminals to continue participating in attacks within the cybercrime ecosystem, considering the value placed on reputation and trust within the cybercriminal community [38, 63, 85, 171].

- *Resistance Operation: How to skirt detection and recover from a take-down*

Generally, hackers do not want to be identified or have their attack detected. Common methods that aim to accomplish this include employing a proxy server to bounce online activities, using anonymous tools such as a Tor network [6, 36, 103], clearing event logs, command history, and shredding history files. To increase the chance of success of a cyber attack, the executive can introduce obfuscations to avoid being detected by the target's defense tools, regularly update an attack's configurations and executable file builds, or use multiple channels and distribute servers across network boundaries [116, 130].

Parts of the cybercrime ecosystem can be taken down by law enforcement, therefore, a plan for recovery is extremely valuable for cybercriminals. For example, the Ramnit botnet that infected 3.2 million computers was taken down in February 2015 but quickly re-emerged and attacked banks and e-commerce operations in Canada, Australia, the United States, and Finland in December 2015 [76]. This is because some of Ramnit's infrastructure survived from the take-down and its operators were not arrested. Additionally, it is believed that the cybercriminals acquired the web injection mechanism from a separate group that provides web injections as a service, making Ramnit even more resilient.

2.2.2 Human Resource: Hacker Community. As discussed above, the hacker forum is the most common form of communication for the cybercriminal community. A hierarchical structure has lower coordination costs than a pure market structure, so most hacker forums have adopted hierarchical management systems consisting of administrators, moderators, reviewers, reviewed vendors, and general members to stratify and organize the community [171].

- **Hacker Training.** There is a limited number of highly skilled hackers [87] and the cybercriminal tends to build a collegial culture that encourages sharing of information and values innovation [64]. Since most hackers are novices, part of the value-added activity for the hacker community is training the novices. Note that both the offensive and defensive sides of cybercrime are

leveraging the same innovations [37], and hackers can learn skills through online cybersecurity forums or even via YouTube videos. The near-term advances in machine learning, automation and artificial intelligence can also be used by the criminals and nation-state adversaries [37] while the attacker may even have the advantage in skill, as the “worst is getting worse faster” [92]. Some hacker communities will offer training programs to train fledgling cybercriminals. For example, the Anonymous launched an online school called OnionIRC allowing members to share technical skills and maintain anonymity [46].

- **Hacker Recruiting.** To grow the hacker community, recruiting is an important activity for the cybercrime ecosystem. To achieve this goal, many tutorials are available to reduce the barriers for the novices to join the hacker community and benefit from the cyber attack. According to the research from Digital Shadows, the process hackers use to recruit new hires is the mirror to its legitimate counterpart [128]: post advertisements on forums, hacker-specific job boards, social networks to reach fresh talents, qualify candidates by application forms or even through interviews, and maintain a time-sensitive membership. The study of 18 investigations into criminal networks [84] demonstrates that the relationships based on real-world social networks play an important role in the origin and growth of the majority of networks while the access to online forums can increase the criminal capabilities quickly. For the nation-supported cyber attacks, the recruiters may even hire hackers with specific experiences from the criminal underworld [144].

2.2.3 *Marketing and Delivery.* The “booming” underground marketing and delivery activities play critical roles for attackers to realize potential benefits from successful cyber attacks.

- **Marketplace.** A marketplace for attackers to trade the digital gains is the principal way for attackers to realize the benefit from successful cyber attacks. We can observe many different dark web marketplaces available for different kinds of goods and services: vulnerability and exploitation [4, 70, 119], dumps, skimmers, identities, attack tools and mules [174], credit card [59], fake tools [153], Bitcoin [123], and so on. Some marketplaces even allow cybercriminals to operate “single-vendor stores”, in the same way as one could do on eBay, where sellers will run their own online website to sell their products to their clients [59]. In June 2017, a black market framework was offered as “platform-as-a-service” for buyers to build their own darknet marketplace [35].

- **Reputation.** Anonymity can translate to uncertainty related to product quality in the hacker community [61, 171]. To mitigate this problem, trust and reputation play fundamental roles in the cybercrime ecosystem [85]. Any activity that a cybercriminal can undertake to show that he or she is trustworthy or to bolster his or her reputation is extremely valuable. It is important for the cybercriminal to make sure a potential trading partner is not in fact law enforcement; the takedown of Shadowcrew is a “painful” example of such a situation in the hacker community [49]. Some forums are open exclusively to well-vetted users and often require a fee to join, and other forums are invite-only [171] while some forums may even request that the members “must hack a website within 3 months” to maintain the membership [128]. Some guarantors will offer vetting services to check a prospective user’s background, contributions, and trustworthiness [50]. Like the legitimate e-commerce sites such as eBay and Amazon, some forums offer a rating system so that members can rate each other and evaluate a potential traders’ reputation. Due to the prevalence of “rippers” who trade dishonestly by double selling, some marketplaces, such as credit card forums, have introduced a mechanism to review prospective vendors’ goods and/or services and assign a “reviewed vendor” tag as an approval of quality if a vendor passes the review [61]; if a reviewed vendor is found to have traded dishonestly, that vendor will face a punishment [171].

- **Value Evaluation.** Since there exist many different digital goods and services in the marketplace, determining the price of a good is a typical value-added task for the hackers. It is no surprise that a zero-day vulnerability will be much more valuable than a one-day vulnerability.

The one-day vulnerability is still valuable because of the observed patch delay in practice [74]. Additionally, the going price changes based on supply and demand in the market. For example, in May 2016, due to the shutdown of Angler, the demand for Neutrino increased so much that the developer doubled the price per month from \$3,500 to \$7,000 [22].

- **Money Laundering.** Money laundering is a traditional activity for underground crime, to make illegally-gained proceeds appear legal [15]. Likewise, money laundering plays a critical value-added role to support the benefit realization activities for cybercriminals, especially for those attackers motivated by financial gains. In addition, the advantage of digital currency—the protocol’s anonymity and resilience through flexibility—enables money launderers to do their business faster, cheaper and more discretely than before.

2.2.4 Technical Support. Cybercrime relies heavily on technical support. Notably, the offensive and defensive sides use similar innovations [37]. Many technologies developed for “good” purposes have been coopted by cybercriminals for less than positive ends. The first IRC (Internet Relay Chat) bot was invented in 1988, then the first malicious bot appeared 10 years later [164]. The anonymous communication network technology Onion Routing (Tor) and the Invisible Internet Project (I2P) were developed to protect privacy online [6, 30]. Bitcoin, a peer-to-peer electronic cash system, was developed to allow any two willing parties to transact directly without the need for a third party [111]. Now these technologies have become the “cornerstones” for cybercriminals.

Additionally, the well-known tools such as *Application Specific Scanners, Debuggers, Encryption Tools, Firewalls, Forensics, Fuzzers, Intrusion Detection Systems, Multi-Purpose Tools, Packet Crafting Tools, Packet Sniffers, Password Crackers, Port Scanners, Linux Hacking Distros, Rootkit Detectors, Traffic Monitoring Tools, Vulnerability Exploitation Tools, Vulnerability Scanners, Web Browser Related Tools, Web Proxies, Web Vulnerability Scanners, and Wireless Hacking Tools*⁷ are used by both cybercriminals and security engineers. For example, Nmap is a very well-known open source hacking tool for network inventory, open port checking, managing service upgrade schedules and monitoring host or service uptime, which is also widely used by attackers to intrude into the victim’s network. Furthermore, many tools developed or customized by professional organizations or experts, even by the state-supported agencies like CIA [168] or NSA [54], may be taken and used to strengthen cybercriminal’s arsenal.

2.3 Cyber Attack Ecosystem: The Combination of Primary and Support Activities

The cyber attack ecosystem consists of not only primary activities directly related to a cyber attack but also support activities that facilitate a cyber attack by reducing costs and increasing benefits. In addition to technical vulnerabilities, attackers also target operational vulnerabilities, the weaknesses related to the processes, policies, and humans in an organization, which are often overlooked. Cyber attack operation activities, including target selection, hacker organization, benefit realization, and resistance measures, can significantly improve attackers’ performance in the digital, direct monetary, and psychological gains. The hacker community is growing in both skill and scale to offer human resources, and marketing and delivery activities are available to further facilitate the benefit realization for cyber attack operation.

In addition, these value-added cyber attack activities are not isolated but related to each other. The cyber attack ecosystem is already well embedded within a comprehensive value chain. Some attackers, especially the highly skilled hackers, can be involved in multiple activities. A more eye-catching scenario is that these activities can be orchestrated to collaborate within a more complex cyber attack, even when they are provided by different actors.

⁷For these tools, we follow the kali linux tool taxonomy. Please check <https://tools.kali.org/tools-listing> for details.

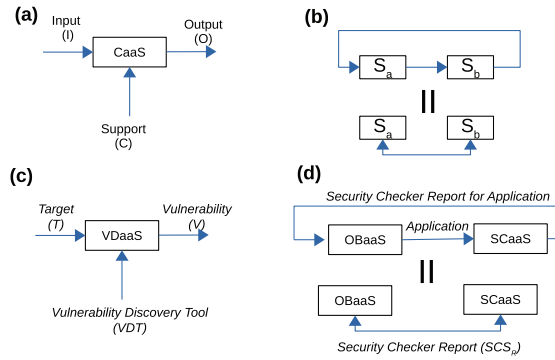

Fig. 2. Cybercriminal Service Model. (a) Each cybercrime value-added activity can be modeled as the service that takes input and produces output using supportive tools or techniques. (b) Two services form the composition based on their dependencies, further constructing a loop, simplified as a double arrow for convenience. (c) Taking the vulnerability discovery as an example, given the a target, using the vulnerability discovery tools, this component identifies the related vulnerabilities as the output. (d) Taking the obfuscation and the security checker components as examples, the obfuscation component (OBaaS) uses the service checker component (SCaaS) to check the obfuscation’s effectiveness. It can continuously involve the security checker until the security check report ($SCSR$) shows that the application can bypass the security software.

Hence, to combat the modern cyber attack effectively, beside the primary attack activities, the defensive community should also pay special attention to those emerging support activities. More importantly, it is critical to understand the cyber attack ecosystem from a systematic perspective, not only focusing on the individual activities but also their relations with each other.

3 CYBERCRIMINAL SERVICE ECOSYSTEM: BUSINESS RECONSTRUCTION

With the development of service science [83], cybercrime as a service (CaaS) has become an important trend for the cybercriminal ecosystem [97, 134, 145]. Cybercriminals are leveraging this innovation to make their products and services more attractive, trustworthy, and more easily delivered. This innovation not only puts cybercriminal tools and services in the hands of a wider range of threat actors, but it also turns the cyber attack into a business that can provide a living for a career cybercriminal [2]. Furthermore, it restructures cybercrime activities and drives attackers even deeper underground, as activities related to cybercrime can now be offered as independent, modular components in a cybercrime supply chain with attackers benefiting from each component. In this section, following the value-added processes discussed in Section 2, we will identify the relevant cyber attack services, to construct a systematic framework for the cybercrime ecosystem, developing an understanding of the business and the evolution of cyber attack itself.⁸

3.1 Service Model: Business Components for Cyber attack

A cyber attack service provider can advertise a cybercrime service offering specific modules related to a cyber attack on the marketplace to reach as many potential users as possible. A buyer can purchase any needed services on a marketplace to build a cyber attack from scratch, or can integrate the purchased services into his or her own operation, becoming a service provider. As shown in Figure 2, to build the systematic framework for the cybercriminal ecosystem, we define

⁸In this article, we will use component and service synonymously. In addition, we further map these services into the value chain model. Please check Section C in the Support Materials for details.

each service as the value-added activity that takes some inputs and produces an output using the support tools and techniques:

Definition 4 (Cybercrime Service). refers to a value-added activity related to a cyber attack that takes input and produces output using the support tools and techniques:

$$\mathbf{O} = CS(\mathbf{I}, \mathbf{C}), \quad (2)$$

where \mathbf{I} refers to the input set for the service, \mathbf{O} refers to the output set for the service, while \mathbf{C} refers to the techniques or tools that support or enable this service. The input, output, or support are not necessarily a single-element set and could be a multi-element, meaning that it involves different types of variables, or even an empty set \emptyset if no variable is necessary for the given parameters.

In the “as-a-Service” model, a cyber attacker can concentrate on a particular value-added activity in the cybercriminal ecosystem, becoming an expert and driving the “*specialization*” for the cyber attack activities. Cybercriminal specialists can then “*commercialize*” their skills as services/products that can support use by many users simultaneously and are intuitive enough so that buyers do not need to understand the details of their execution to use them. To overcome defensive efforts and execute a successful cyber attack, a cyber attack executive may combine related services so that they “*cooperate*” in performing more complex tasks to improve the performance of a cyber attack. Based on the definition above, if the output set of a service CS_a intersects with the input or support of another service CS_b , then there will exist a value-adding path from CS_a to CS_b , and these two services can collaborate with each other to form a composition and lend an advantage in performing complex attack activities.

Definition 5 (Cybercrime Service Composition). Given two cybercrime services, they can collaborate with each others as a composition for value-adding and form a complex attack activity if and only if there exist intersections between the output set of the previous service and the input or support of the next service.

Note that the output set of the previous service does not need to be equal to the input or support of the next service. Once there exists some intersection, then they can collaborate with each other to generate added value. Hence, with the adoption of the “as-a-Service” model for cybercrime, *specialization*, *commercialization*, and *cooperation* in the cybercriminal ecosystem form the crux of the cybercrime business. In the following sections, based on the value chain model presented in Section 2 and the service model discussed above, we will formally identify the unique cybercriminal services,⁹ including those directly related to the primary activities and those indirectly supporting a cyber attack, and how they collaborate with each other for the cyber attack.

In the following sections, using the value chain model presented above, we will define and describe the key cybercrime services, listed in Table 1, along the current status, examples (with references), and sample pricing.

3.2 Cybercrime Services Directly Related to Primary Activities

The cybercrime services directly related to primary activities consist of the services for the primary activities, and the related supportive activities to overcome the defensive efforts and to improve the cyber attack performance.

⁹In this article, we are focusing on the added value and the business in the cybercriminal ecosystem, so the technical details, or cyber attack mechanisms, as discussed in many studies like References [9, 19, 20, 23, 125, 150, 156], are out of scope. We consider the attack service as a “black box” as the buyers do not need to understand the details of the services they purchase.

Table 1. Status and Typical Pricing of Cybercrime Services

Service	Status	Pricing Model	Example Case	Estimated Price
EaaS	Existing	License	Exploit Trading [71]	up to more than \$250,000
		Subscription	Up-to-date Zero-day Exploits [151]	\$150,000 per month
PLaaS	Existing	Pay-per-install Commission	Payload Renting [10, 16]	\$0.02–0.10 per install 40%
DaaS	Existing	Subscription	Phishing Service [145]	\$85–\$115 per month 40%
		Commission	Fake Anti-virus [97]	
OBaaS	Existing	Subscription	Obfuscation Platform [50]	\$50–150 per month
SCaaS	Existing	Subscription	Scan4you [72]	\$25 per month
TRaaS	Existing	Pay-per-click	Traffic Redirection [50]	\$7–\$15 per 1,000 visitors
BNaas	Existing	Subscription	Botnet Shops [145]	\$40 per month
BHaaS	Existing	Subscription	Cloud Bulletproof Servers [100]	\$300 per month
TAaaS	Existing	Subscription	DDoS Attack Service [134]	\$999 per month
REaaS	Existing	Pay-per-record	Reputation Escalation Markets [170]	\$0.4–0.7 per record
MPaaS	Existing	License	Market Framework [35]	\$4,500 per licence
		Commission	Marketplace [34]	2%–10%
MRaaS	Existing	License	Money Laundering Recruitment Package [99]	\$1,700 per licence
MLaaS	Existing	Commission	Money Laundering Service [127]	2%–30%
HTaaS	Existing	License	Hacker Training Courses [138]	\$250–\$800 per person
PPaaS	Evolving	License	Personal Profile Investigator [59]	\$4–\$20 per record
TPaaS	Evolving	Subscription	“One-stop-shop” Platform [2, 73]	\$4,000 per month
RaaS	Evolving	Subscription	Smart Contract [79]	/
HRaaS	Evolving	Subscription	Online Hacker Recruiting Market [105]	/
VDaaS	Emerging	Subscription	Bug Bounty Program [132]	\$542.04–\$1810.31 per vulnerability
TSaaS	Emerging	Subscription	Targets Ranking based on Value [101]	/
EPaaS,RPaaS	Emerging	Subscription	Repackaging Platform [143, 151]	\$4,000 per month
DMaaS	Emerging	Subscription	“How-to” Knowledge Systems [27]	/
VEaaS	Emerging	Subscription	Comparison “Shopping” Service [57]	/

Services are defined and explained in the following sections. Examples for existing services are actual, emerging, and evolving services are based on offensive versions of actual legitimate services. Prices listed here are intended to be representative of current prices and are constantly evolving.

3.2.1 Vulnerability Discovery as a Service (VDaaS). For the vulnerability discovery service, given the target as the input, with the support from the vulnerability discovery tools, potential vulnerabilities of the target are identified and returned as outputs. We define VDaaS as follows:

$$\mathbf{V} = VDaaS(\mathbf{T}, \mathbf{VDT}), \quad (3)$$

where \mathbf{T} is the target, which can be the information system or an employee in a specific organization, or a specific information product series like Windows 10 operating system. \mathbf{V} refers to the discovered vulnerabilities related to the given target \mathbf{T} , including technical vulnerability V_t and operational vulnerability V_p . \mathbf{VDT} refers to the vulnerability discovery tools such as Metasploit, Wireshark, or W3af. Note that the more specific the given target is, the more targeted the cyber attack based on the discovered vulnerability can be.

It is not a surprise that in the underground cybercrime ecosystem, hackers trade their discovery directly in the dark web [4]. However, vulnerability discovery is a nontrivial, time consuming,

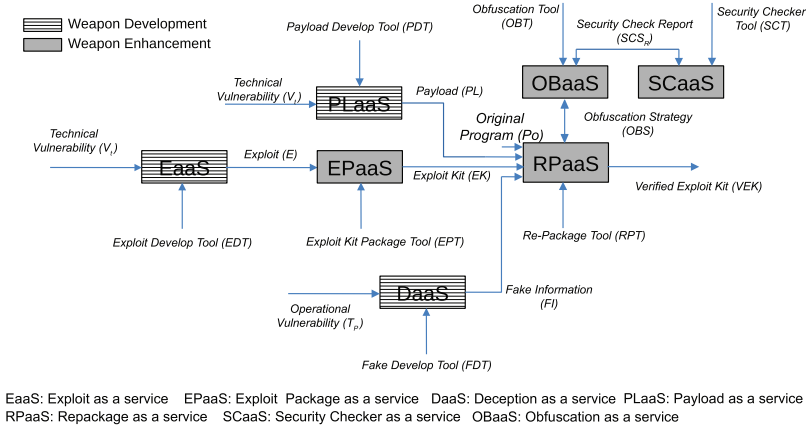

Fig. 3. Exploitation Development Service (EKaaS). “Weapon development” means the service is related to transfer the vulnerability into the weapon that can be used for attack. “Weapon enhancement” means the service is used to improve the effectiveness of the weapons.

uncertain, but highly valuable task. Google even launched a vulnerability research grant to reward “security researchers that look into the security of Google products and services even in the case when no vulnerabilities are found” [51]. Hence, it is rare to observe the independent vulnerability discovery services in the cybercriminal ecosystem. Only some highly skillful hackers, especially the organized cybercrime hackers, can offer services to help the clients to identify vulnerabilities in a target system. Given the success of the bug bounty programs [69, 95, 173], where organizations reward external experts who discover vulnerabilities in their systems and patch them before they are publicly disclosed, it is very possible that deep in the dark web there will exist offensive-versions of “bug bounty programs,” where a platform is offered to take advantage of the hacker community to dig the vulnerability within a given target. Considering the menacing targeted cyber attacks, aka, advanced persistent threat (APT) [146], this VDaaS as the offensive bug bounty programs is very likely to be reality, if it does not exist yet, in the cybercriminal ecosystem.

3.2.2 Exploitation Development Service (EKaaS). An exploit is a program that takes advantage of discovered *technical vulnerabilities* to make a target’s systems perform in an abnormal way. Hackers can package exploits in an exploit kit to simplify and increase the success rate of attacks. To avoid being detected by defensive security software, exploit kits can include components to obfuscate their true functionality. Additionally, exploit kits can integrate additional payloads to bolster an attack on potential targets. For the *operational vulnerability*, the attacker can deploy a fake WiFi, website, software, message, or email to exploit the discovered operational weaknesses. Hence, the exploit development service is the service that converts discovered vulnerabilities into effective cyber attack weapons with the support of development tools. As shown in Figure 3, the independence between different components can be used to increase the cyber attack performance and overcome the defensive efforts. For example, in the exploitation development process, the “weapon development” services can be used to transfer a vulnerability into an attack weapon and the “weapon enhancement” services can be used to improve its effectiveness for cyber attack.

• **Exploit as a Service (EaaS).** Given the discovered technical vulnerability V_t , the exploit E is developed with the support of the exploit development tool set EDT. We can model EaaS as

$$E = EaaS(V_t, EDT). \quad (4)$$

Normally, when the vulnerability is discovered, the proof-of-concept trial is also developed to demonstrate its practicality. We can explore many verified exploitations in ExploitDB [33]. While responsible vulnerability disclosure policy ensures the release of a patch before any details of the vulnerability are publicly revealed, it is possible for the hackers to automatically develop the exploitation [8] or reverse-engineer the patch without the relevant details [14]. Though the automatic exploitation generation is fairly basic now [143], it is not surprising to observe new tools to support this highly valuable activity.

- **Exploit Package as a Service (EPaaS).** Given a collection of exploits E , EPaaS combines them into the exploit kit EK that is potentially more effective than any individual exploit. An unintelligent exploit kit, one that delivers all its exploits at once regardless of the conditions in the victim's systems, may adversely affect the performance of other active exploits and increase the possibility of detection. Meanwhile, intelligent exploit kits are developed to take into account the target's conditions when delivering an exploit [50]. In most exploit kits, the exploitative programs and strategies are hard-coded, but this may not be the case for long; exploit kits can be developed in such a way to enable dynamic updates as conditions change. Consider the following definition:

$$EK = EPaaS(E, EPT), \quad (5)$$

where EPT refers to the strategies and tools used to package the exploits into exploit kit.

- **Deception as a Service (DaaS).** Given the operational vulnerability V_p , with the support of the development tools FDT, this component generates the fake information FI, like a fake website [88, 167], fake emails [60, 118], or fake software [153], which can be delivered to the target. A DaaS is defined as follows:

$$FI = DaaS(V_p, FDT). \quad (6)$$

Note that if the V_p contains detailed information about the specific target, like organization structure, business process, or network environment, the attack is referred to as targeted attack [145], and normally it will have a higher probability of success. For example, in a whaling phishing attack in early 2016, employee payroll information was successfully stolen when an employee voluntarily gave it away in an email to whom he thought to be the company's CEO [107].

- **Payload as a Service (PLaaS).** This component offers the payloads PL involved in a cyber attack. A payload [18, 40, 139] can refer to an atomic malicious program performing a singular function, or a combination of many independent ones to offer a more complex, comprehensive functionality. PLaaS is defined in terms of the following relationship:

$$PL = PLaaS(V_t, PDT), \quad (7)$$

where PDT refers to the tools used to develop the payload.

- **Obfuscate as a Service (OBaaS).** Given an application, such as exploit E , exploit kit EK , fake information FI , payload PL , this component uses various obfuscation strategies and technologies, such as packers, polymorphism, and metamorphism, to reduce the chance that an application is detected by antivirus software [53, 116, 136]. For example, the Q implementation [137, 143] can be used to harden the exploits generated by the EaaS. Some may include security software to confirm the effectiveness of the obfuscation [50]. We define OBaaS in terms of the following relationship:

$$A_O = OBaaS(A_I, \{OBT, SCS_R\}), \quad (8)$$

where A_I refers to the input application, such as a payload, exploit kit, exploit, or fake information, while A_O refers to the output application with obfuscation methods applied; OBT refers to the obfuscation tools and strategies; SCS_R refers to the interactions with the security checkers, if any.

- **Security Checker as a Service (SCaaS).** This component verifies whether a given application can bypass the defensive barrier from a certain security software or platform [53]. If an application

is detected by a security software, then the OBaaS component can update the obfuscation strategy until the application goes undetected, resulting in a loop between the OBaaS and SCaaS,

$$SCS_R = SCaaS(A_I, SCT), \quad (9)$$

where A_I refers to the input application from OBaaS and SCS_R refers to the report from the security checker tool set SCT. For example, cybercriminals once used Google's VirusTotal platform to verify the effectiveness of malware [172]. It is believed that for the Ukrainian power grid attack, the attacker built a simulated power grid system similar to the Ukrainian power grid plant that they were able to evaluate and test the developed firmware prior to the attack [39]. As shown in Figure 3(d), OBaaS and SCaaS can form a loop to guarantee the effectiveness of the developed cyber weapons. Given the high value for this loop, it is not surprising to observe these platforms, which may even be operated similarly to the mobile app testing cloud [47] for the mobile ecosystem.

- **Repackage as a Service (RPaaS).** Given a list of inputs, this component packages the elements of the input in a verified exploit kit to increase the effectiveness of an attack, with support from obfuscation component, OBaaS, and repackaging tools. We define RPaaS as

$$VEK = RPaaS(A_I, \{RPT, OBS\}), \quad (10)$$

where A_I refers to the input, which can be the payload PL from PLaaS, exploit kit EK from EPaaS, fake information FI from DaaS, the original benign application P_o , or their combinations; VEK refers to the application that will be delivered to the target for cyber attack; RPT refers to the repackaging tools and strategies to enhance the input. This component plays an important role for the cyber attack. Take the payload development as an example. Since a payload may be identified by security software, hackers will revise detected payloads using the repackage component so that they may bypass detection on subsequent attacks [18]. This iterative process creates a so-called "family" of payloads [18, 157]. To circumvent detection more effectively, an advanced payload protects itself through redundant actions and encryption [116]. The malware "Dendroid" is even capable of detecting emulated environments such as Google Bouncer [155], and the WannaCry malware can detect whether the running environments are sandboxes [96]. This dynamic awareness is what sets apart intelligent cyber weapons from their less sophisticated counterparts. For the exploit kit from EPaaS, the automated shellcode placement methods are developed to generate the modified exploit by changing or replacing the original shellcode of the existing exploit for new attacks [9].

Until now, we have discussed the main value-added components related to exploitation development in the "as-a-service" model. The EaaS (exploit), PLaaS (payload), and DaaS (fake information) are related to develop the weapons to attack the victims based on the discovered vulnerability, which belongs to the "exploitation development" activities. Meanwhile, the EPaaS (exploit kit package), the RPaaS (repackage), the OBaaS (obfuscation), and the SCaaS (security checker) are used to improve the effectiveness of the developed weapons, which belongs to the support activities "resistance operation." Based on Figure 3, various ways can be observed that exploitation services can be combined. For a given cyber attack, at least one of the "exploitation development" activities will be employed, while the "resistance operation" component is not a must. However, the more services an attacker can effectively employ, the higher the chance of success in an attack will be. For example, when applying the generated verified exploit kits, the VEK will be more difficult to detect for security programs and more effective in the attack.

Additionally, the employed services can be used simultaneously or in different phases of a multi-step attack. For example, in the Ukraine power grid cyber attack [39], the spear-fishing emails from DaaS (fake information), the exploit kit targeting vulnerabilities, including CVE-2014-4114, CVE-2010-3333 from EPaaS (exploit kit), the KillDisk, a destructive data-wiping utility, and the SSH

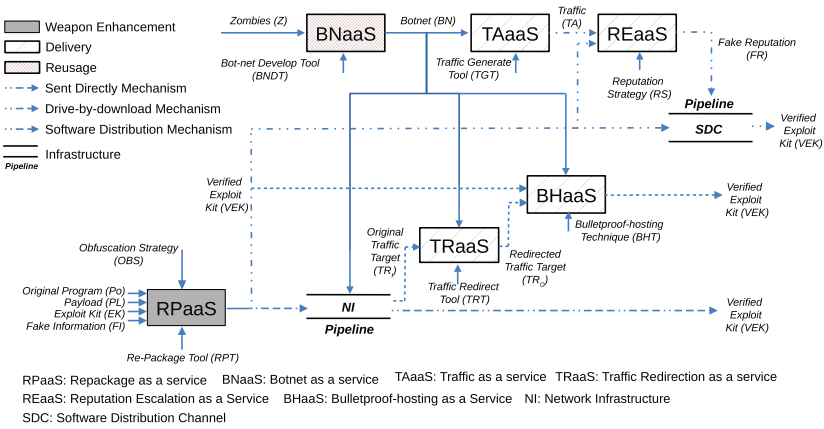

Fig. 4. Exploitation Delivery Services. “Delivery” refers to services serving to support the exploitation delivery. “Reusage” refers to services repurposing gains from previous successful attacks. “Infrastructure” refers to network infrastructures that are operated by network infrastructure operators and serve as the pipeline.

backdoor to maintain persistent access from PLaaS (payload), were used in tandem to successfully break into the Ukrainian power grid system. In the second step of the same attack, malicious firmware (from PLaaS) developed based on domain knowledge collected from the distribution management system, which was tested by the simulated power grid system (from SCaaS), was uploaded to the system and to attack the ICS components.

3.2.3 *Exploitation Delivery Service (EDaaS)*. As shown in Figure 4, the purpose of these activities is to deliver the exploitative programs VEK from EKaaS to the targeted systems. Effectively, EDaaS serves as a pipeline for the cybercrime ecosystem, consisting of the following components:

- **Botnet as a Service (BNaaS)**. As presented in [129], given a list of compromised machines, called zombies, a developer can use tools, such as Zeus and Aldi, to implement a Botnet that is controlled by a human operator, the bot-master, in some cases through Command and Control (C&C) channels. To improve resilience with respect to being taken down, a bot-master may use tools, such as multi-hopping, ciphering, binary obfuscation, polymorphism, IP spoofing, Email spoofing, and fast-flux network, to maintain and update a botnet.

$$BN = BNaaS(Z, BNDT), \tag{11}$$

where Z refers to a set of zombie machines, BN refers to the botnets, and $BNDT$ is the tool set to develop and maintain the botnet [129].

- **Traffic Redirection as a Service (TRaaS)**. Using this component, incoming web traffic to a specific address will be redirected to a server hosting the verified exploit kits, which is a fundamental component for the “drive-by-download” mechanism. A typical example is search-engine poisoning, in which cyber-criminals compromise links to popular websites and redirect search traffic to the other websites [67, 167]. We formally define TRaaS as

$$TR_O = TRaaS(TR_I, \{TRT, BN\}), \tag{12}$$

where TR_I refers to the original traffic target, and TR_O refers to the redirected traffic target, TRT is the traffic redirection technique [48, 159], and BN can be used to construct a fast-flux network to support traffic redirection [65].

- **Bulletproof Hosting as a Service (BHaaS)**. Bulletproof hosting services, such as Russian Business Network, McColo, Troyak, and Vline [78], are a lot more lenient about the contents hosted

on their servers so that the attackers can host most types of materials on them without worrying about being taken down: the service provider must make the servers harder to seize and be inconspicuous enough to avoid calling the attention of authorities [100]. Furthermore, the providers intend to host the servers in countries with more relaxed laws to make it easier to evade law enforcement [12]. Supported by the botnet, some providers will hire the compromised servers out until they are discovered [100]. This kind of service is used by cybercriminals as the “gang’s hideout” and is widely available in the underground market due to its emphasis on anonymity.

$$VEK_O = BHaaS (\{VEK_I, TR\}, \{BHT, BN\}), \quad (13)$$

where **BHT** refers to the tools and strategies that protect the servers, such as located offshore, moving among different service providers, registering and dropping network blocks frequently [5], making them “bulletproof.”

- **Traffic as a Service (TAaaS)**. This component may use many servers or sources, typically the botnet **BN**, to generate the traffic for the given target. One typical scenario is the well-known DDoS attack [75], which flood the bandwidth or resources of the targeted system, usually one or more web servers, with traffic from multiple compromised systems. For example, on October 21, 2016, a botnet consisting of tens of millions of Internet-connected devices infected by Mirai flooded Dyn’s servers, resulting in 11h of blocked access to popular websites such as Twitter, Spotify, Netflix, Amazon, Tumblr, Reddit, and Paypal, among others [11]. Another typical application for this component is in an advertising fraud scheme, in which fake traffic generates vast amounts of undeserved revenue [44]. We formally define TAaaS in terms of the following relationship:

$$TA = TAaaS (BN, TGT). \quad (14)$$

- **Reputation Escalation as a Service (REaaS)**. For the “software distribution” mechanism, this component will exploit the vulnerability of the current recommendation system [141] to craft a fake reputation [170] for the given malicious applications. Due to the fake ratings, search engines or rating services will list them as a popular service. This will significantly increase the exposure of the malicious applications. We formally define REaaS as

$$FR = REaaS (\{A_I, TA\}, RS), \quad (15)$$

where **A_I** refers to the given malicious applications and **TA** refers to the traffic used to generate the fake reputation **FR**, and **RS** refers to mechanisms to establish reputation on a given platform.

3.2.4 Multi-step Attack Service (AaaS). Once a target’s systems are compromised, the avenue for attack is open and cybercriminals make their entrance seeking benefits of the following forms: digital gains (**GD**) including intellectual property, sensitive information, domain knowledge, compromised machines, or even a targeted user who can be manipulated; psychological gains (**GP**) affecting reputation, and monetized forms of benefit (**GL**) from damages incurred by targets. When performing a cyber attack, a cybercriminal must hide the attack from detection using an obfuscation strategy (**OBS**) informed by relevant domain knowledge (**DK**). Examples that have already been discussed include the attack on the Bangladesh Bank’s (BB) SWIFT payment system [142], where attackers clearly exhibited knowledge of SWIFT operations, which may be from willing—or coerced—domain experts, and the Ukraine power grid attack [39], in which power grid network structure information is believed to have been collected in previous attacks. Considering the necessary human resources (**HR**) services supporting a cybercrime operation in addition, we can define the component representing the attack itself as follows:

$$\{GD, GP, GL\} = AaaS (\{VEK, TA\}, \{OBS, HR, DK\}). \quad (16)$$

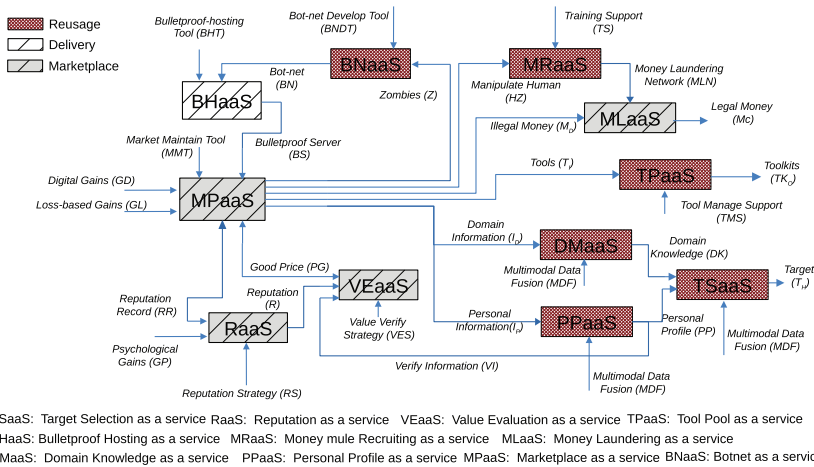

Fig. 5. Marketplace and Gain Reuse. “Marketplace” refers to the services to enable the trade for benefit realization while “Reusage” refers to the services that reuse the digital gains from previous successful cyber attacks to facilitate further attacks.

Until now, we have explored the value-added processes of the primary activities and the directly related supportive services behind a cyber attack. In the following sections, we will discuss the supporting components that are not directly related to a cyber attack but nonetheless critical to operations in the cybercrime ecosystem.

3.3 Cybercriminal Services Indirectly Supporting Primary Activities

There exist support services related to benefit realization, which are focusing on monetization of cyber attack gains through different marketplaces. Personal profile information can be listed for sale or exposed publicly on underground markets to damage the organization or individual to whom the information belongs [117]; domain information is extremely valuable for the targeted cyber attack [146]; compromised computers can be sold to assemble a botnet [129]; the stolen tools can be used to construct the toolkits that offer “one-stop-shop” tool support [77]; while a manipulated person can serve as the money mule [66]. For direct monetary gains, attackers can collect benefits directly from their victims; however, if it proves too difficult or risky for attackers to interact with victims to realize benefits, attackers can opt to trade the potential benefit on the market, supported by the value evaluation services. For example, a group of underground cybercriminals created Ran\$umBin—a dark web service to monetize ransomware attacks—that allows cybercriminals to upload stolen data and motivate victims to pay to get back their stolen data [120]. Psychological gains can help attackers build reputation in the hacker community. Furthermore, to mitigate identity and quality uncertainty [171], the reputation and pricing systems are important for the cybercriminal ecosystem. Finally, but straightforwardly, offering the marketplace to enable the trading is a fundamental component for the cybercriminal ecosystem. Hence, as shown in Figure 5, we can identify the additional re-usage components beside BNaaS for the digital gains, and the marketplace components.

3.3.1 Digital Gain Reuse Service. Through the marketplace, these components turn the digital gains from the successful cyber attacks into services that can be reused to facilitate the further cyber attack.

• **Personal Profile as a Service (PPaaS)**. This component offers personal profile **PP** about targets such as passport numbers, driver’s licenses, email accounts, social media accounts, or credit card numbers. Any personal information I_p that can be used to build a complete personal profile, for an individual or an organization can be included in this component, whether it comes from data breaches [166] or public sources on the internet, such as social media pages.

$$PP = PPaaS(I_p, MDF), \quad (17)$$

where **MDF** refers to the multimodal data fusion [82] that can be used to manage and analyze the collected data. It is extremely valuable, because different data sets can interact and inform each other [17] to offer value-adding information about the targets. One typical application could be offering the detail information for the given individual or organization for the buyers, which can be used for further attack, especially for a whaling phishing attack [60, 66].

• **Domain Knowledge as a Service (DMaaS)**. This component refers to domain information I_d gained from past attacks to offer specific knowledge **DK** relevant to future attacks with the support of the developing data manage and analysis technology **MDF**:

$$DK = DMaaS(I_d, MDF). \quad (18)$$

The basic form of the domain knowledge is the step-by-step guidance for cyber attack. Inspired by the emergences of the WikiHow, eHow, Howcast, and so on, which offers extensive information about how-to tasks, as well as the development of the knowledge graph techniques [27], the DMaaS in the cybercriminal ecosystem could evolve into the similar how-to knowledge systems that can be used across different scenarios.

• **Tool Pool as a Service (TPaaS)**. Cyber attacks, like the CIA breach [168] or NSA cyber incident [54], and the HackerTeam hack [62], can result in cybercriminals gaining access to hacking tools used by the targeted organizations that can be repurposed and applied in future cybercrimes. Hacker communities, often cybercrime groups or nation-support groups, will collect these tools T_I and develop new variants to address their specific goals. Since these tools can benefit the entire cybercrime ecosystem by facilitating new attacks, it is no surprise that toolkits or platforms TK_O on the dark web exist to facilitate the access to these tools. For example, the “Shadow Brokers” offered a subscription-based service [77] with access to up-to-date exploits gained from the NSA cyber incident. We can formally define TPaaS as

$$TK_O = TPaaS(T_I, TMS), \quad (19)$$

where **TMS** refers to the technology enabling tool customization and management.

• **Target Selection as a Service (TSaaS)**. As discussed above, informed target selection is very valuable in the cybercrime ecosystem, because it can significantly reduce the cost and increase the benefit from the cyber attack. Given the availability of personal information and domain knowledge, as well as the development of advanced data analysis and artificial intelligence, it is possible for attackers to identify the valuable targets based on the expected benefit and cost, before they actually perform the cyber attack. Hence, we can expect the emergence of target selection as a service for the cybercriminal ecosystem [101]. We formally define TSaaS as follows:

$$T_H = TSaaS(\{PP, DK\}, MDF), \quad (20)$$

where T_H refers to the identified valuable targets, which may even be ranked according to the different value for different attackers.

3.3.2 Marketplace Service. To support monetization efforts on dark web marketplaces, bullet-proof servers are necessary to guarantee the availability and reliability of these services. The following components are important to bridge the gap between the dark web and legitimate businesses by money laundering, mitigate the identity through reputation system and reduce quality uncertainty by value evaluation and pricing.

- **Money Laundering as a Service (MLaaS).** Given the illegal, “dirty” money M_D from a cyber attack, this component makes use of a money laundering network MLN to make it appear as though it was earned by legal means M_C . We define MLaaS as follows:

$$M_C = MLaaS(M_D, MLN). \quad (21)$$

Note that the M_C could also be in the form of digital currency, such as Bitcoin [80], since Bitcoin can be easily cashed out via digital currency trading platforms such as BTC-E or exchanged with each other [123]. MLN refers to the money laundering network consisting of many money mules, who make available their own bank or digital accounts to be used as conduits for transferring money out of the cybercrime ecosystem for a fee [25, 43, 66].

- **Money Mule Recruiting as a Service (MRaaS).** To recruit the money mules who will make up a money laundering network, the mule herders, those who establish connections with would-be money mules, send out believable fake emails advertising normal jobs such as Financial Department Manager and contact the recipients who respond to the email. These individuals will be trained and brought into the money laundering network [148].

$$MLN = MRaaS(HZ, TS), \quad (22)$$

where HZ refers to the people acting as the money mules in the money laundering network MLN , who could be tricked to join the network, because it is an acceptable “job” for them, especially if they are unemployed [1]. TS refers to training support, including tools and related knowledge. Normally, the DaaS component is a prerequisite for the MRaaS component, since MRaaS relies on creating and distributing fake emails.

- **Reputation as a Service (RaaS).** Reputation is very important in the cybercrime ecosystem as it serves as a metric to mitigate the uncertainty associated with dealing users who hide their true identities [171]. As a result, most marketplaces, especially forums, incorporate a reputation mechanism into their core service that generates a reputation rating based on a user’s previous interactions in the marketplace. To warn the underground visitors to stay away from fraudsters,¹⁰ some third-party services such as Ripper.cc and Kidala.info [158] were developed to maintain a database of rippers.

$$R = RaaS(\{GP, RR\}, RS), \quad (23)$$

where GP refers to the previous conducted attacks of the given user, while RR refers to the interaction records, and R refers to the user’s reputation determined by the reputation evaluation mechanism RS , which can be similar to the mechanisms [141] employed by a legitimate business.

- **Value Evaluation as a Service (VEaaS).** Similar to a legitimate business, judging the value of goods traded in a marketplace plays a fundamental role to mitigate the risk associated with quality uncertainty [171]. In the case of credit cards, the quality of a stolen card may depend on the credit limit of the account, and this will drive the price. Recently, Fatboy, a new ransomware-for-hire scheme, automatically adjusts its ransom demands according to the Big Mac Index, a measurement that shows to what extent the currencies are overvalued or undervalued [52]. Some cybercriminals

¹⁰In the cybercriminal ecosystem, it is not clear who are the “good guys” and “bad guys.” A “fraudster” can be actually a law enforcement associate trying to track down hackers [171]. The attackers can even conduct attacks against each other [21].

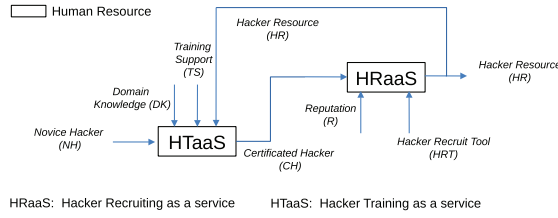

Fig. 6. Human resource service. These services prepare the necessary human resource for the cyber attack business through training and recruiting.

can use scanned documents, like passports, to confirm other users' identities. For example, a hacker may verify a Paypal account with a scanned copy of the purported owner's passport [50].

$$PG_O = VEaaS (\{PG_I, R, VI\}, VES), \quad (24)$$

where PG_I refers to the goods offered by the providers on the marketplace; R refers to the seller's reputation; VI refers to the verify information, which can be part of the personal profile from $PPaaS$; VES is the methodology to evaluate the value to determine the good's price PG_O .

- **Marketplace as a Service (MPaaS).** As discussed above, the marketplace is a fundamental component, serving as the trading place to realize the benefit from the cyber attacks. It serves as a pipeline to transfer the gains from a successful cyber attack into input for many different types of services, which can facilitate further cyber attacks, and monetary benefit, which can be made as legal through money laundering.

$$\{G_O, M_D\} = MPaaS (G_I, \{MMT, BS, RR, PG\}), \quad (25)$$

where G_I refers to the products or services traded in the marketplace, which can be the digital gains GD or the loss-based gains GL from a cyber attack. Note that each service mentioned in this article can also be traded in the marketplace, including the $MPaaS$ itself can also be available in the dark web to build a specific marketplace for some attackers. G_O refers to the different types of materials like personal information I_p , domain information I_d , stolen tool set T_I , compromised machines Z , manipulate human HZ . M_D refers to the illegal monetary benefit the seller achieve from the trading; MMT refers to the tool and technique to build the marketplace in the dark web, BS refers to the bulletproof server to host the marketplace; RR refers to the seller's activities records while PG refers to the evaluate value for the goods, representing the support from the $RaaS$ and $VEaaS$ to mitigate the identity and quality uncertainty.

3.3.3 Human Resource Service. The main functionality of human resources is to train novice hackers so that they attain the necessary skills to participate in cyber attacks, and to recruit new hackers to join the community or to participate in a specific cyber attack. As shown in Figure 6, it consists of the following two main services:

- **Hacker Training as a Service (HTaaS).** Given specific domain knowledge related to a cyber attack, this component helps a hacker, especially a novice hacker, gain skills relevant to cybercrime and become a qualified member in the hacker community. In its most basic form, $HTaaS$ offers step-by-step guides or online school like OnionIRC [46]. Nowadays, it has grown into an industry of its own, and is not necessarily an underground activity or an illegal business at this point. For example, the "Offensive Security" provides the "true performance-based penetration testing training" [138] offering certifications once training is completed, and even runs a bug bounty program to reward those who find qualifying vulnerabilities in their sites.

$$CH = HTaaS (NH, \{DK, TS, HR\}), \quad (26)$$

where **NH** refers to the hackers without the specific hacking skill, who are normally the novice in the community; **CH** refers to the hackers gaining the necessary skills, namely certificated hackers; **DK** refers to the necessary domain knowledge; **TS** refers to the tools or platforms supporting training; **HR** refers to the hackers who can offer the training materials, such as personal experience, domain knowledge, or mentorship.

- **Hacker Recruiting as a Service (HRaaS)**. Cybercriminals may need to recruit additional hackers to collaborate on a particular attack. As an example, a nation-state sponsoring a cyber-crime operation may hire non-affiliated hackers to carry out an attack, reducing the political risk that accompanies the sponsorship of cybercrime [144].

$$HR = HRaaS (CH, \{R, HRT\}), \quad (27)$$

where **HR** are the hacking resources that can be used for an attack while **CH** are the available, certificated hackers; **R** refers to support from the reputation system RaaS; **HRT** refers to the tools or platforms to recruit the reliable hackers to join the group or to participate into a cyber attack.

4 CYBERCRIMINAL SERVICE ECOSYSTEM FRAMEWORK

Following the value chain model presented in Section 2, we have identified 24 key value-added services¹¹ related to cybercrime activities in primary and supporting roles. Using the definitions about service composition discussed above, we can combine these services, preserving their dependencies, to form the systematic framework shown in Figure 7. It can be seen that the cyber-crime ecosystem can be viewed as a complete cyber-threat capability supply chain. The discovered vulnerabilities from “Vulnerability Discovery” can be transformed into effective weapons by “Exploitation Development” for cyber attacks. “Resistance Operation” activities make a cyber attack more powerful and better suited to avoid detection. The “Delivery” activities represent the act of delivering cyber attack weapons to their targets. “Marketplace Support” activities create the platforms for cybercriminals to trade the gains from successful attacks, while “Reusage” activities re-purpose these gains to enable further attacks, serving as the “Benefit Realization” component in the value chain. “Human resource” activities represent human resources that support the cyber-crime ecosystem. Finally, the tools and platforms to support these identified services are parts of the “Technology Support” in the value chain model. Furthermore, using this framework, we can systematically understand the hacking innovations in the cybercriminal ecosystem, including the development of these cybercriminal services, and the emerging services, like “cybercriminal service composition as a service.”

4.1 Cybercriminal Service Development

4.1.1 Service Status. Based on the above discussions, we follow the value-added processes to construct the cybercriminal service ecosystem framework,¹² to integrate widely scattered services into a consistent framework and to understand these services’ development. As shown in Table 1, for most identified services, we can observe many actual cases on the dark web. More importantly, as the offensive side and defensive side use similar innovations, the innovations in the context of legitimate businesses can drive the evolution of components in the cybercriminal service ecosystem. Hence, it is reasonable to expect that, even for those services that have not yet been observed as independent services, if they do not already exist, the offensive versions of legitimate

¹¹Please check Section B in Support Materials to see the glossary.

¹²Please check Section C in Support Materials for discussions about the mapping to value chain model and developments for each service.

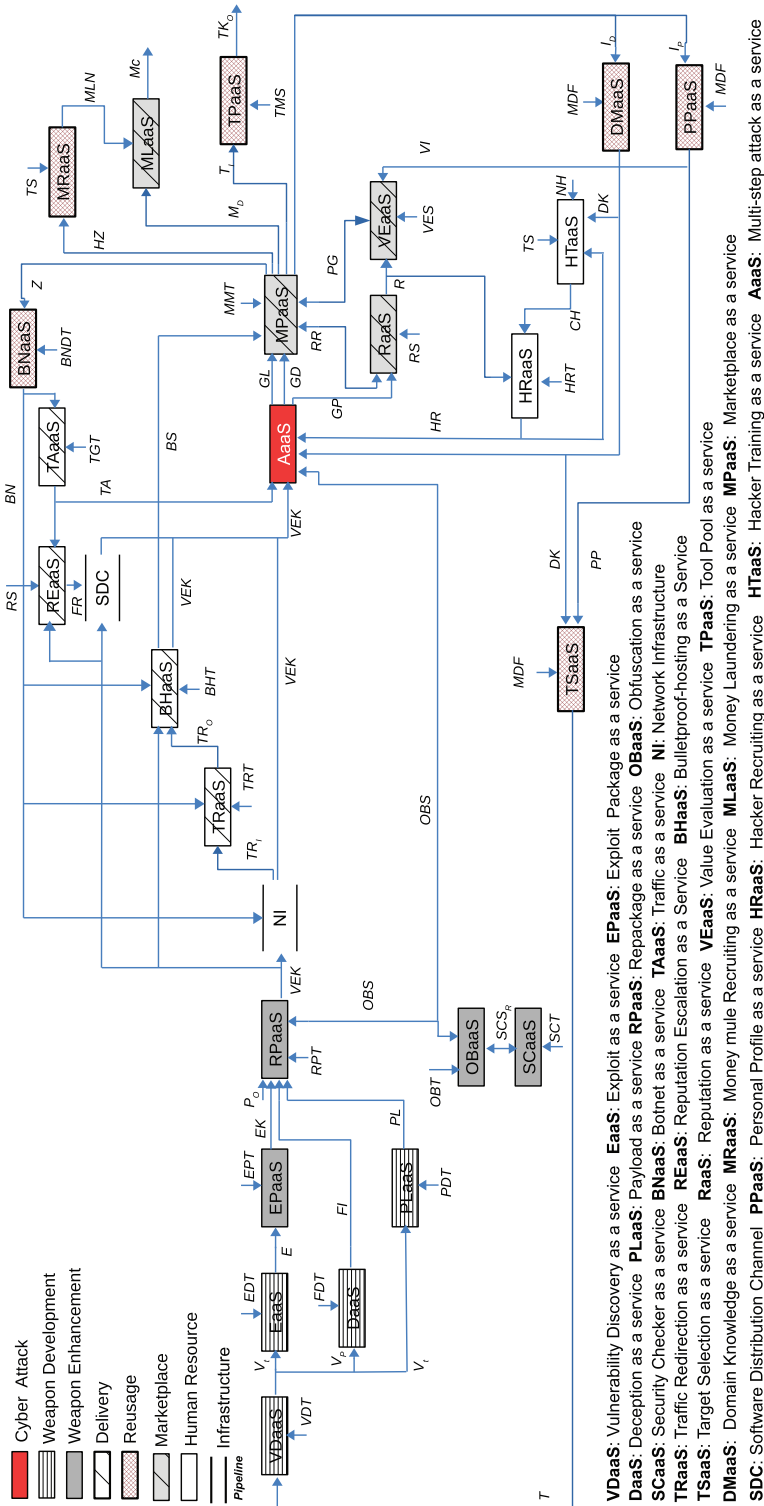

Fig. 7. Cybercriminal Service Ecosystem Framework: systematic understanding of the cyber attack business based on the identified services and their dependencies, including 25 services, their supported tools and two related network infrastructures.

defensive techniques are likely to emerge. Therefore, these identified services can be grouped into three different categories based on their availability:

- **Existing Services** refers to the existing services whose business model is not expected to change significantly in a short term.
- **Evolving Services** refers to the services that are currently available in the dark web, in some form, but are expected to evolve into a new service model due to technological development. For example, in the cybercriminal service ecosystem, new reputation mechanisms like smart contract based on blockchain technology [79] or cyber grand challenge [9, 169] could be further developed to mitigate the uncertainty, beside existing services like Ripper.cc and Kidala.info to maintain a database of rippers [158], or relationships based on real-world social networks [84].
- **Emerging Services** refers to the services, though not observed as independent services on the dark web yet but expected to emerge, due to their specialization, the desirability of such services, and the existence of the similar innovations in legitimate businesses. Taking TSaaS as an example, given the rapid growth of the targeted cyber attack [91, 101, 146], targets ranking based on value can spread to and prove popular in the dark web.

4.1.2 Service Pricing Mechanism. For the pricing mechanism, some services, especially those providing digital goods, are generally offered with one-time fees and unlimited use. For example, the price of EaaS, which provides exploit using this license model, range from free to up to more than \$250,000, depending on its exploited vulnerability. It is important to realize that the cyber-crime ecosystem is constantly evolving and the pricing models and prices even more so. The prices listed in our table are intended to be representative of current prices.

Increasingly, service providers charge buyers based on outputs or require commission sharing from successful cyber attacks. One example is the Pay-per-install model [16] for PLaaS, where buyers purchase the service and pay only \$0.02–\$0.10 for each successful installment. Another example is REaaS in the reputation escalation markets where buyers buy “fault positive” feedback records with a very low price at \$0.4–\$0.7 per record. One eye-catching example of requiring commission sharing price mechanism recently is that the “GandCrab,” a ransomware payload service discovered in January, 2018 offers a partner program, in which members share 40% profits with the developers[10]. Another pricing mechanism uses a subscription model that the buyer pays a membership to access provided service. One example is that the Shadow Brokers released zero-day vulnerabilities and exploits as a subscription-based service—“TheShadowBrokers Dump Service”[151]. Notably, providers may adopt various pricing models for different customers at different service prices for a given service.

4.1.3 Rapid Growth of Services. Based on the presented framework, it can be expected that services with more available inputs tend to grow faster. For instance, the increasing occurrence of data breach incidents [166] will enable the growth of the PPaaS (personal profile) and DMaaS (domain knowledge) in our framework, which will further drive the development of TSaaS (target selection). With TSaaS is an input to the “weapon development” process for targeted cyber attacks, the cost for a whaling phishing will substantially drop and therefore whaling phishing attacks can scale up. Due to the advancement of target selection services, we can foresee more personalized, large-scale cyber attacks.

We can also expect that services located at crossroads of many value-added paths will grow more rapidly. One example for this is “Repackage-as-a-Service (RPaaS).” As this type of service becomes more available, it is very possible that we will experience a significant number of new malware attacks relying on repackaged payloads and new obfuscation methods. A sign for this is

that repackaging attacks are becoming common for mobile devices, especially for Android ecosystem [143]. More importantly, services in the framework are not isolated. They actually have already formed four reinforcing loops, including the reuse of the compromised machines, stolen tools, stolen information, and hacking experience. These loops and interactions among services enable each cyber incidence to reinforce and empower other incidences.¹³

4.2 Profitability of Cybercriminal Business: The Emergence of Composition Services

As discussed above, components for a cyber attack are offered as services that a would-be attacker can purchase on the dark web to equip themselves for an attack. To analyze the profitability of the cybercriminal business, we use the ransomware attack as an example. The price of each involving service are based on the observed instances in the dark web. For the benefit, we use the indicators from the Angler revenue reported by Cisco [28] as a baseline but make a much more conservative estimate acknowledging the defensive efforts.

- **Costs of sample services.** To run a ransomware attack as a business, a cybercriminal can buy BNaaS (botnet) for \$999 per month, a traffic redirection protocol for \$600, six servers as a part of BHaaS (bulletproof server) for \$1,800 per month, access to the Neutrino exploit kit in EPaaS (exploit package) for \$4,000, a ransomware payload with customer support in PLaaS (payload) for \$3,000 and the traffic redirection service TRaaS to redirect victims to servers for \$600 per month. To further increase the effectiveness of an attack, a cybercriminal can hire a qualified hacker from HRaaS for \$2,000 per month, and employ an obfuscation service from OBaaS to repackage the exploit kit and payload for \$600 per month. Finally, to reduce risk of arrest, services to monetize benefits in the wake of a cyber attack as a part of MLaaS (money laundering) can be accessed for a fee of \$400 and 40% commission on processed funds.

- **Example of Return on Investment (ROI).**¹⁴ For calculating benefit, we assume that 30,000 people are redirected per day, of which 10% are victims of a ransomware attack where 0.5% of victims pay a \$300 ransom. Though only 450 victims (0.05% of total users redirected) will end up paying the ransom over a period of one month (30 days), this brings the cybercriminal's monthly earnings to \$135,000. We can see that the Return-On-Investment (ROI), even when only a small proportion of people end up paying a ransom, is as high as 504.52%, an impressive ROI for a business. Using the reports from CSIMarket [32] for comparison, the highest industrial ROI, which is from the Tobacco industry, is only 50.63% in August 2017; in fact, this theoretical cybercrime operation would be ranked as one of the top seven best performing companies in the world in terms of ROI. If we use the numbers from the Angler revenue report, which shows that 9,515 users pay the ransom per month, a number more than 20 times larger than the 450 users dictated by our assumptions, then the ROI of this operation would reach 12,682.30%.

- **Cybercriminal service composition as a service.** Hence, we can conclude that combining separate services to perform a cyber attack has great value for cybercriminals. This motivates the emergence of *“cybercriminal service composition as a service.”* In this scenario, hackers can collaborate and apply services available on multiple dark web marketplaces and combine them together to offer a “one-stop shop”-style service, which will continuously reduce the barriers to entry of cybercrime and performing complex cyber attacks. More importantly, this development would allow cybercriminals in the cybercrime ecosystem to focus on the parts of the value chain model at which they are best and provide their expertise as a service to other cybercriminals. Following this “specialization, commercialization, and cooperation” trend, cybercriminals may be

¹³Please check Section D in Support Materials for discussions about the cyber threat reinforcements.

¹⁴Please refer to Section E in Support Materials for more details about the benefit and cost.

able to hide themselves even deeper, and in certain cases, some of their activities may no longer be characterized as illegal.

5 CONCLUSION AND IMPLEMENTATION

The “double-edged sword” nature of cybersecurity technology means that the defensive and offensive sides use similar innovations, and until now, the offense has been able to nurse its advantage: “the bad guys are getting badder faster.” Cybercrime is no longer just a hobby. Cybercrime has become a business, and even less-than-prodigious hackers may choose it as a profession. The cybercrime ecosystem has evolved to encompass a comprehensive supply chain built around certain value-added processes. Furthermore, recent “as-a-service” innovations accelerate the evolution of the cybercrime ecosystem and the growth of the cybercrime business, reconstructing into a specialization, commercialization, and cooperation system. Without a systematic understanding of this trend in the cybercrime ecosystem, effectively combatting cyber attacks will be difficult.

This article provides a comprehensive survey of cybercrime services, based on an extensive literature review and publicly available reports, and organized them using a value chain framework. We see that aside from the primary activities of vulnerability discovery, exploitation development, exploitation delivery, and attack, many support activities are emerging to facilitate cyber attacks, including attack lifecycle operations, human resource management, marketing and delivery, and technology support. These activities are not isolated but can collaborate with each other. Combining the value chain model with the developments of the “as-a-service” innovations, we can model cybercrime activities as service components with inputs, outputs, and supports. In this way, we can identify the relationships between components and construct a global view of this underground business: the cybercrime service ecosystem framework. The framework enables us to systematically understand the hacking innovations in the cybercriminal ecosystem, including the cybercriminal service’s development (availability status, pricing model, and growth), as well as the emergence of composition service: “cybercriminal service composition as a service,” which can offer “one-stop-shop”-style cyber attack services for the cybercriminal ecosystem.

Finally, based on the systematic understanding about the cyber attack business, the framework inspires several strategies to more effectively combat cyber attacks, including¹⁵:

- **Striking the dark side by identifying the Control Points to improve effectiveness.**

Inspired by Reference [29], we can define the control point as “*the critical components which can support the other components in the cybercriminal service ecosystem.*” Based on the presented cybercrime ecosystem framework, if we can use “honeypots” to monitor the important control points in the cybercrime ecosystem, representing the value-added paths of the cyber-threat supply chain, we can achieve a better understanding of the underlying economy of cybercrime and profile what has until now been the “dark side” of a cyber attack. Furthermore, such a scheme could also help law enforcement associates collecting critical evidence to convict cybercriminals and to strike at the heart of cybercrime business. Another interesting aspect is that given the uncertainties related to identity and quality, the cybercriminal market is a typical “market for lemons” [108, 167]. If the defensive side can flood the cybercriminal ecosystem with honeypot-style or deceptive goods, then it will make the dark web less attractive for cybercriminals looking to purchase services. For example, as Hansa (one of the largest dark web markets) was once compromised by police but kept running, now hackers are suspecting that the other dark web markets, like “Dream Market,” was also compromised in a similar manner and under police control [45]. In addition, the framework can help to access the effectiveness and the side-effect for the cybersecurity policies. For example, HRaaS (hacker recruit) serves a control-point role to recruit

¹⁵Please check Section G in Support Materials for more detailed discussions about these two examples.

skillful hackers into the cybercriminal ecosystem. Without considering its impact, the efforts to train cybersecurity workforce [37] for defensive side will also increase the cybercriminal workforce supply.

- **Assigning responsibility to different actors for meaningful collaboration.**

There exist several challenges plaguing cybersecurity and cybersecurity policy when it comes to working together to build a safer connected world [108]: the externalities, the misaligned incentives, and the information asymmetries. These market failures call for implementation of policy to allocate responsibilities to different parties so cybersecurity can be improved in the places where economic forces disincentive it. Given the presented cybercrime ecosystem framework, we can identify which responsibilities or actions fall to which actors based on whether the actors have the capability to take the actions, including the *individuals and corporations, software/hardware providers, security companies, infrastructure operators, financial systems, governments, and third-party threat intelligence service providers*. For example, the government has an important role in combatting cybercrime, given its position to address market failures related to cybersecurity and strategies to recruit skilled individuals to the defensive side and combat incentives that drive them to join the cybercrime business should be considered. Intuitively, only emphasizing the *individuals and corporations* to protect themselves is not an effective policy. All these actors need to take specific responsibilities and collaborate with each other to strike the cyber threat capability supply chain. Policies to motivate them to take actions are urgently needed.

Overall, by conceptualizing the modern cyber attack business systematically, we will be able to design better strategies to combat cyber attacks. More research about how to disrupt the business of cybercrime by stymieing the development of the threat capability supply chain in the cybercrime ecosystem is needed for the security community.

ACKNOWLEDGMENTS

The authors thank members from the Cybersecurity at MIT Sloan for their valuable comments and inputs. In addition, we thank all the reviewers for their comments and improvements.

REFERENCES

- [1] ABC NEWS. 2008. Bad economy helping Web scammers recruit mules. Retrieved from <http://abcnews.go.com/Technology/story?id=6428943>.
- [2] Lillian Ablon, Martin C. Libicki, and Andrea A. Golay. 2014. *Markets for Cybercrime Tools and Stolen Data: Hackers' Bazaar*. Technical Report. RAND Corporation. 1–85.
- [3] Yasemin Acar, Michael Backes, Sven Bugiel, Sascha Fahl, Patrick Mcdaniel, and Matthew Smith. 2016. SoK: Lessons learned from Android security research for appified software platforms. In *Proceedings of the 2016 IEEE Symposium on Security and Privacy*. 433–451.
- [4] Abdullah M. Algarni and Yashwant K. Malaiya. 2014. Software vulnerability markets: Discoverers and buyers. *Int. J. Comput., Electr., Automat., Control Info. Eng.* 8, 3 (2014), 480–490.
- [5] Sumayah Alrwais, Xiaojing Liao, Xianghang Mi, Peng Wang, XiaoFeng Wang, Feng Qian, Raheem Beyah, and Damon McCoy. 2017. Under the shadow of sunshine: Understanding and detecting bulletproof hosting on legitimate service provider networks. In *Proceedings of the 2017 IEEE Symposium on Security and Privacy*. 805–823.
- [6] Mashael Alsabah and Ian Goldberg. 2014. Performance and security improvements for Tor: A survey. *Comput. Surveys* 49, 2 (2014), 1–38.
- [7] Ross Anderson, Chris Barton, Rainer Böhme, Richard Clayton, Michel J. G. van Eeten, Michael Levi, Tyler Moore, and Stefan Savage. 2013. Measuring the cost of cybercrime. In *The Economics of Information Security and Privacy*. Springer-Verlag Berlin Heidelberg 2013, 265–300.
- [8] Thanassis Avgerinos, Sang Kil Cha, Brent Lim, Tze Hao, and David Brumley. 2011. AEG: Automatic exploit generation. In *Proceedings of the 18th Annual Network and Distributed System Security Symposium*, Vol. 14. 1–18.
- [9] Tiffany Bao, Ruoyu Wang, Yan Shoshitaishvili, and David Brumley. 2017. Your exploit is mine: Automatic shellcode transplant for remote exploits. In *Proceedings of the IEEE Symposium on Security and Privacy*. 824–839.
- [10] Bradley Barth. 2018. RIG and GrandSoft exploit kits shell out new GandCrab ransomware. Retrieved from www.scmagazine.com/rig-and-grandsoft-exploit-kits-shell-out-new-gandcrab-ransomware/article/740900/.

- [11] Eli Blumenthal and Elizabeth Weise. 2016. Hacked home devices caused massive Internet outage. Retrieved from <https://www.usatoday.com/story/tech/2016/10/21/cyber-attack-takes-down-east-coast-netflix-spotify-twitter/92507806/>.
- [12] Danny Bradbury. 2014. Testing the defences of bulletproof hosting companies. *Netw. Secur.* 2014, 6 (2014), 8–12.
- [13] Russell Brandom. 2017. An Anonymous group just took down a fifth of the dark web. Retrieved from <https://www.theverge.com/2017/2/3/14497992/freedom-hosting-ii-hacked-anonymous-dark-web-tor>.
- [14] David Brumley, Pongsin Poosankam, Dawn Song, and Jiang Zheng. 2008. Automatic patch-based exploit generation is possible: Techniques and implications. In *Proceedings of the IEEE Symposium on Security and Privacy*. 143–157.
- [15] Danton Bryans. 2014. *Bitcoin and Money Laundering: Mining for an Effective Solution*. Vol. 89. Indiana Law Journal, 441–472.
- [16] Juan Caballero, Chris Grier, Christian Kreibich, and Vern Paxson. 2011. Measuring pay-per-install: The commoditization of malware distribution. In *Proceedings of the USENIX Security Symposium*. 13:1–13:16.
- [17] Vince D. Calhoun and Tülay Adalı. 2009. Feature-based fusion of medical imaging data. *IEEE Trans. Info. Technol. Biomed.* 13, 5 (2009), 711–720.
- [18] Alejandro Calleja, Juan Tapiador, and Juan Caballero. 2016. A look into 30 years of malware development from a software metrics perspective. In *Proceedings of the International Symposium on Research in Attacks, Intrusions, and Defenses*, Vol. 9854 LNCS. 325–345.
- [19] Davide Canali and Davide Balzarotti. 2013. Behind the scenes of online attacks: An analysis of exploitation behaviors on the web. In *Proceedings of the 20th Annual Network & Distributed System Security Symposium*.
- [20] Onur Catakoglu, Marco Balduzzi, and Davide Balzarotti. 2016. Automatic extraction of indicators of compromise for web applications. In *Proceedings of the World Wide Web Conference*. 333–343.
- [21] Onur Catakoglu, Marco Balduzzi, and Davide Balzarotti. 2017. Attacks landscape in the dark side of the web. In *Proceedings of the ACM Symposium on Applied Computing*. 1739–1746.
- [22] New Jersey Cybersecurity & Communications Integration Cell. 2016. Exploit kit variants: Neutrino. Retrieved from <https://www.cyber.nj.gov/threat-profiles/exploit-kit-variants/neutrino>.
- [23] Jian Chang, Krishna K. Venkatasubramanian, Andrew G. West, and Insup Lee. 2013. Analyzing and defending against web-based malware. *Comput. Surveys* 45, 4 (2013), 1–35.
- [24] Chia Yuan Cho, Domagoj Babic, Pongsin Poosankam, Kevin Zhijie Chen, Edward XueJun Wu, and Dawn Song. 2011. MACE: Model-inference-assisted concolic exploration for protocol and vulnerability discovery. In *Proceedings of the USENIX Security Symposium*. 139–154.
- [25] Kim-Kwang Raymond Choo. 2011. The cyber threat landscape: Challenges and future research directions. *Comput. Secur.* 30, 8 (2011), 719–731.
- [26] Nicolas Christin. 2013. Traveling the silk road: A measurement analysis of a large anonymous online marketplace. In *Proceedings of the 22nd International Conference on World Wide Web*. 213–224.
- [27] Cuong Xuan Chu, Niket Tandon, and Gerhard Weikum. 2017. Distilling task knowledge from how-to communities. In *Proceedings of the World Wide Web Conference*. 805–814.
- [28] Cisco. 2016. *Cisco 2016 Annual Security Report*. Technical Report. Cisco. 1–87.
- [29] David D. Clark. 2012. Control point analysis. In *Proceedings of the TRPC Conference*. 25. Retrieved from <http://papers.ssrn.com/sol3/papers.cfm?abstract>.
- [30] Bernd Conrad and Fatemeh Shirazi. 2014. A survey on Tor and I2P. In *Proceedings of the 9th International Conference on Internet Monitoring and Protection*. 22–28.
- [31] Contagio. 2015. An Overview of Exploit Packs (Update 25) May 2015. Retrieved from <http://contagiodump.blogspot.com/2010/06/overview-of-exploit-packs-update.html>.
- [32] CSIMarket. 2017. CSIMarket return on investment screening. Retrieved from <https://csimarket.com/screening/index.php?s=roi>.
- [33] Exploit Database. 2017. The exploit database. Retrieved from <https://www.exploit-db.com/>.
- [34] DEEPDOTWEB. 2018. Updated: List of Dark Net Markets. Retrieved from <https://www.deepdotweb.com/2013/10/28/updated-llist-of-hidden-marketplaces-tor-i2p/>.
- [35] DEEPWEBADMIN. 2017. Build a black market in dark web only for \$4500; Cybercrime goes PAAS. Retrieved from <https://www.deepweb-sites.com/build-black-market-dark-web-4500-cybercrime-goes-paas/>.
- [36] Roger Dingledine, Nick Mathewson, and Paul Syverson. 2004. Tor: The second-generation onion router. Naval Research Lab Washington DC.
- [37] Thomas Donilon, Chair Samuel Palmisano, Keith Alexander, Ana Antón, Ajay Banga, Steven Chabinsky, Patrick Gallagher, Peter Lee, Herbert Lin, Heather Murren, Joseph Sullivan, Maggie Wilderotter, and Kiersten Todt. 2016. *Commission on Enhancing National Cybersecurity*. Technical Report. NIST, 1–100.
- [38] Benoit Dupont, Anne-Marie Cote, Claire Savine, and David Decary-Hetu. 2016. The ecology of trust among hackers. *Global Crime* 17, 2 (2016), 129–151.

- [39] Rober M. Lee, Michael J. Assante, and Tim Conway. 2016. *Analysis of the Cyber Attack on the Ukrainian Power Grid*. Technical Report. SANS ICS and E-ISAC, 23.
- [40] Manuel Egele, Theodor Scholte, Engin Kirda, and Christopher Kruegel. 2012. A survey on automated dynamic malware-analysis techniques and tools. *Comput. Surveys* 44, 2 (2012), 1–42.
- [41] Jose Esteves, Elisabete Ramalho, and Guillermo de Haro. 2017. To improve cybersecurity, think like a hacker. *MIT Sloan Manage. Rev.* 58, 3 (2017), 71–77.
- [42] Adrienne Porter Felt and David Wagner. 2011. Phishing on mobile devices. In *Web 2.0 Security and Privacy*, Vol. 2. 1–10.
- [43] Kristin M. Finklea and Catherine A. Theohary. 2015. *Cybercrime: Conceptual Issues for Congress and U.S. Law Enforcement*. Technical Report. Congressional Research Service, R42547, 1–27.
- [44] Thomas Fox-Brewster. 2016. Android Gooligan hackers just scored the biggest ever theft of Google accounts. Retrieved from <https://www.forbes.com/sites/thomasbrewster/2016/11/30/gooligan-android-malware-1m-google-account-breaches-check-point-finds>.
- [45] Thomas Fox-Brewster. 2017. Forget Silk Road, cops just scored their biggest victory against the dark web drug trade. Retrieved from <https://www.forbes.com/sites/thomasbrewster/2017/07/20/alphabay-hansa-dark-web-markets-taken-down-in-massive-drug-bust-operation>.
- [46] Anonymous France. 2016. Anonymity and privacy first lesson taught on OnionIRC. Retrieved from <https://www.anonymous-france.eu/anonymity-and-privacy-first-lesson-taught-on-onionirc.html>.
- [47] Jerry Gao, Xiaoying Bai, Wei-Tek Tsai, and Tadahiro Uehara. 2014. Mobile application testing: A tutorial. *Computer* 47, 2 (2014), 46–55.
- [48] Glen Gibb, Hongyi Zeng, and Nick McKeown. 2012. Outsourcing network functionality. In *Proceedings of the ACM Workshop on Hot Topics in Software Defined Networking (HotSDN'12)*. 73. Retrieved from <http://dl.acm.org/citation.cfm?doid=2342441.2342457>.
- [49] Misha Glenny. 2011. *DarkMarket: Cyberthieves, Cybercops and You*. Retrieved from <http://books.google.nl/books?id=uxAcuzbyw9YC>
- [50] Max Goncharov. 2012. *Russian Underground 101*. Technical Report. Trend Micro. 1–29.
- [51] Google. 2015. Vulnerability Research Grant Rules. Retrieved from <https://www.google.com/about/appsecurity/research-grants/>.
- [52] Diana Granger. 2017. Fatboy Ransomware-as-a-Service Emerges on Russian-Language Forum. Retrieved from <https://www.recordedfuture.com/fatboy-ransomware-analysis/>.
- [53] Mariano Graziano, Davide Canali, Leyla Bilge, Andrea Lanzi, and Davide Balzarotti. 2015. Needles in a haystack: Mining information from public dynamic analysis sandboxes for malware intelligence. In *Proceedings of the 24th USENIX Security Symposium*. 1057–1072.
- [54] Andy Greenberg. 2016. Hackers claim to auction data they stole from NSA-linked spies. Retrieved from <https://www.wired.com/2016/08/hackers-claim-auction-data-stolen-nsa-linked-spies/>.
- [55] Gustavo Grieco, Guillermo Luis Grinblat, Lucas Uzal, Sanjay Rawat, Josselin Feist, and Laurent Mounier. 2016. Toward large-scale vulnerability discovery using machine learning. In *Proceedings of the ACM Conference on Data and Application Security and Privacy*. 85–96.
- [56] Felix Gröbert, Ahmad-Reza Sadeghi, and Marcel Winandy. 2009. Software distribution as a malware infection vector. In *Proceedings of the International Conference for Internet Technology and Secured Transactions*. 1–6.
- [57] Chen Hajaj, Noam Hazon, and David Sarne. 2017. Enhancing comparison shopping agents through ordering and gradual information disclosure. *Auton. Agents Multi-Agent Syst.* 31, 3 (2017), 696–714.
- [58] Ashley Harris. 2016. *Cyber Ethics: An assessment of government and private industry*. Ph.D. Dissertation. Utica College.
- [59] Andreas Haslebacher, Jeremiah Onaolapo, and Gianluca Stringhini. 2016. All your cards are belong to us: Understanding online carding forums. *CoRR abs/1607.00117* vol. 1. Retrieved from <http://arxiv.org/abs/1607.00117>.
- [60] Ryan Heartfield and George Loukas. 2015. A taxonomy of attacks and a survey of defence mechanisms for semantic social engineering attacks. *Comput. Surveys* 48, 3 (2015), 1–39.
- [61] Cormac Herley and Dinei Florêncio. 2010. Nobody sells gold for the price of silver: Dishonesty, uncertainty and the underground economy. In *Economics of Information Security and Privacy*. Springer Science+Business Media, LLC, 33–53.
- [62] Alex Hern. 2015. Hacking Team hacked: Firm sold spying tools to repressive regimes, documents claim. Retrieved from <https://www.theguardian.com/technology/2015/jul/06/hacking-team-hacked-firm-sold-spying-tools-to-repressive-regimes-documents-claim>.
- [63] Thomas J. Holt. 2017. Identifying gaps in the research literature on illicit markets on-line. *Global Crime* 18, 1 (2017), 1–10.

- [64] Thomas J. Holt, Deborah Strumsky, Olga Smirnova, and Max Kilger. 2012. Examining the social networks of malware writers and hackers. *Int. J. Cyber Criminol.* 6, 1 (2012), 891–903.
- [65] Thorsten Holz, Christian Gorecki, Konrad Rieck, and Felix C. Freiling. 2008. Measuring and detecting fast-flux service networks. In *Proceedings of the Network and Distributed System Security Symposium (NDSS'08)*. 24–31.
- [66] Jason Hong. 2012. The current state of phishing attacks. *Commun. ACM* 55, 1 (2012), 74–81.
- [67] Danny Yuxing Huang, Doug Grundman, Kurt Thomas, Abhishek Kumar, Elie Bursztein, Kirill Levchenko, and Alex C. Snoeren. 2017. Pinning down abuse on google maps. In *Proceedings of the 26th International World Wide Web Conference*. 1471–1479.
- [68] Keman Huang, Jinjing Han, Shizhan Chen, and Zhiyong Feng. 2016. A skewness-based framework for mobile app permission recommendation and risk evaluation. In *Proceedings of the International Conference on Service-Oriented Computing*. 252–266.
- [69] Keman Huang, Michael Siegel, Stuart Madnick, Xiaohong Li, and Zhiyong Feng. 2016. Diversity or concentration? Hackers' strategy for working across multiple bug bounty programs. In *Proceedings of the IEEE Symposium on Security and Privacy*. 2.
- [70] Keman Huang, Jia Zhang, Wei Tan, and Zhiyong Feng. 2017. Shifting to mobile: Network-based empirical study of mobile vulnerability market. *IEEE Trans. Services Comput.* 99 (2017), 1–14.
- [71] Inj3ct0r. 2018. Oday.today. Retrieved from <https://oday.today>.
- [72] Steven K. 2011. Tracking cyber crime: scan4you.net (Private AV Checker). Retrieved from <http://www.xylibox.com/2011/10/scan4younet-private-av-checker.html>.
- [73] Vitaly Kamluk and Alexander Gostev. 2016. *Adwind-a Cross Platform RAT*. Technical Report. Kaspersky.
- [74] Karthik Kannan, Mohammad S. Rahman, and Mohit Tawarmalani. 2016. Economic and policy implications of restricted patch distribution. *Manage. Sci.* 62, 11 (2016), 3161–3182.
- [75] Mohammad Karami, Youngsam Park, and Damon McCoy. 2016. Stress testing the booters: Understanding and undermining the business of DDoS services. In *Proceedings of the 25th International Conference on World Wide Web*. 1033–1043.
- [76] Limor Kessem. 2015. The return of Ramnit: Life after a law enforcement takedown. Retrieved from <https://securityintelligence.com/the-return-of-ramnit-life-after-a-law-enforcement-takedown/>.
- [77] Swati Khandelwal. 2017. Shadow brokers, who leaked WannaCry SMB exploit, are back with more 0-days. Retrieved from <http://thehackernews.com/2017/05/shadow-brokers-wannacry-hacking.html>.
- [78] Maria Konte and Nick Feamster. 2015. ASwatch: An AS reputation system to expose bulletproof hosting ASes. In *Proceedings of the SIGCOMM Conference on Communications Architecture & Protocols (SIGCOMM'15)*. 625–638.
- [79] Ahmed Kosba, Andrew Miller, Elaine Shi, Zikai Wen, and Charalampos Papamanthou. 2016. Hawk: The blockchain model of cryptography and privacy-preserving smart contracts. In *Proceedings of the 2016 IEEE Symposium on Security and Privacy*. 839–858. DOI : <http://dx.doi.org/10.1109/SP.2016.55>
- [80] Brian Krebs. 2016. Money mule gangs turn to Bitcoin ATMs. Retrieved from <https://krebsonsecurity.com/2016/09/money-mule-gangs-turn-to-bitcoin-atms/>.
- [81] Nir Kshetri. 2006. The simple economics of cybercrimes. *IEEE Secur. Priv.* 4, 1 (2006), 33–39.
- [82] Dana Lahat, Tulay Adali, and Christian Jutten. 2015. Multimodal data fusion: An overview of methods, challenges, and prospects. *Proc. IEEE* 103, 9 (2015), 1449–1477.
- [83] Angel Lagares Lemos, Florian Daniel, and Boualem Benatallah. 2015. Web service composition: A survey of techniques and tools. *Comput. Surveys* 48, 3 (2015), 1–41.
- [84] E. R. Leukfeldt. 2014. Cybercrime and social ties: Phishing in amsterdam. *Trends Organ. Crime* 17, 4 (2014), 231–249.
- [85] Rutger Leukfeldt. 2015. Organised cybercrime and social opportunity structures: A proposal for future research directions. *Eur. Rev. Organ. Crime* 2, 2 (2015), 91–103.
- [86] Kirill Levchenko, Andreas Pitsillidis, Neha Chachra, Brandon Enright, Mark FelegyhaziGrier, Chris Grier, Tristan Halvorson, Chris Kanich, Christian Kreibich, He Liu, Damon McCoy, Nicholas Weaver, Vern Paxson, Geoffrey M. Voelker, and Stefan Savage. 2011. Click trajectories: End-to-end analysis of the spam value chain. In *Proceedings of the IEEE Symposium on Security and Privacy*. 431–446.
- [87] Weifeng Li, Hsinchun Chen, and Jay F. Nunamaker Jr. 2017. Identifying and profiling key sellers in cyber carding community : AZSecure text mining system. *J. Manage. Info. Syst.* 33, 4 (2017), 1059–1086.
- [88] Xiaojing Liao, Damon Mccoy, and Elaine Shi. 2016. Characterizing long-tail SEO spam on cloud web hosting services. In *Proceedings of the World Wide Web Conference*. 321–332.
- [89] Vincent Loy, Kyra Mattar, Tan Shong Ye, Bahgya Perera, Jimmy Sng, and Maggie Leong. 2015. *Reclaiming Cybersecurity: The Global State of Information Security Survey 2016*. Technical Report. PwC. 1–8.
- [90] Yong Lu, Xin Luo, Michael Polgar, and Yuanyuan Cao. 2010. Social network analysis of a criminal hacker community. *J. Comput. Infor. Syst.* 51, 2 (2010), 31.

- [91] Robert Luh, Stefan Marschalek, Manfred Kaiser, Helge Janicke, and Sebastian Schrittwieser. 2017. Semantics-aware detection of targeted attacks: A survey. *J. Comput. Virol. Hack. Techn.* 13, 1 (2017), 47–85.
- [92] Stuart Madnick. 2016. Dark Web: Hackers trump good guys in sharing information. (2016).
- [93] Stuart Madnick. 2017. Preparing for the cyberattack that will knock out U.S. power grids. *Harvard Bus. Rev.* (2017), 5. <https://hbr.org/2017/05/preparing-for-the-cyberattack-that-will-knock-out-u-s-power-grids>.
- [94] Stuart Madnick. 2017. What executives get wrong about cybersecurity. *Sloan Manage. Rev.* January (2017), 22–24.
- [95] Thomas Maillart, Mingyi Zhao, Jens Grossklags, and John Chuang. 2016. Given enough eyeballs, all bugs are shallow? Revisiting Eric Raymond with bug bounty programs. In *Proceedings of the Workshop on the Economics of Information Security (WEIS'16)*. 1–19.
- [96] MalwareTech. 2017. How to accidentally stop a global cyber attack. Retrieved from <https://www.malwaretech.com/2017/05/how-to-accidentally-stop-a-global-cyber-attacks.html>.
- [97] Derek Manky. 2013. Cybercrime as a service: A very modern business. *Comput. Fraud Secur.* 6 (2013), 9–13.
- [98] Steve Mansfield-Devine. 2016. The imitation game: How business email compromise scams are robbing organisations. *Comput. Fraud Secur.* 11 (2016), 5–10.
- [99] Etay Maor. 2013. No money mule, no problem: Recruitment website kits for sale. Retrieved from <https://securityintelligence.com/money-mule-problem-recruitment-website-kits-sale/>.
- [100] Max Goncharov. 2015. *Criminal Hideouts for Lease: Bulletproof Hosting Services*. Technical Report. Trend Micro. 28 pages.
- [101] Inc. McAfee. 2016. *McAfee Labs 2017 Threats Predictions*. Technical Report. McAfee. 1–51.
- [102] Michael McCaul. 2017. The war in cyberspace: Why we are losing—How to fight back. Retrieved from <https://www.rsaconference.com/videos/the-war-in-cyberspace-why-we-are-losing-and-how-to-fight-back>.
- [103] Damon McCoy, Kevin Bauer, Dirk Grunwald, Tadayoshi Kohno, and Douglas Sicker. 2008. Shining light in dark places: Understanding the Tor network. In *Proceedings of the International Symposium on Privacy Enhancing Technologies Symposium*. 63–76.
- [104] Michael McGuire. 2012. *Organised Crime in the Digital Age*. Technical Report. London: John Grieve Centre for Policing and Security.
- [105] McKinsey & Company. 2015. *A Labor Market That Works : Connecting Talent With Opportunity in the Digital Age*. Technical Report. McKinsey & Company. 88.
- [106] William Melicher, Blase Ur, Sean M Segreti, Saranga Komanduri, Lujo Bauer, Nicolas Christin, and Lorrie Faith Cranor. 2016. Fast, lean, and accurate: Modeling password guessability using neural networks. In *Proceedings of the Usenix Security Conference*. 239.
- [107] Max Metzger. 2016. Snapchat got whaled, employee payroll released. Retrieved from <https://www.scmagazineuk.com/snapchat-got-whaled-employee-payroll-released/article/530493/>.
- [108] Tyler Moore. 2010. Introducing the economics of cybersecurity: Principles and policy options. In *Proceedings of the Workshop on Deterring Cyberattacks: Informing Strategies and Developing Options for U.S. Policy*. 3–23.
- [109] Steve Morgan. 2016. *Hackerpocalypse : A Cybercrime Revelation*. Technical Report. Cybersecurity Ventures. 1–24.
- [110] Robert S. Mueller III. 2012. Combating threats in the cyber world: Outsmarting terrorists, hackers, and spies. Retrieved from <https://archives.fbi.gov/archives/news/speeches/combating-threats-in-the-cyber-world-outsmarting-terrorists-hackers-and-spies>.
- [111] Satoshi Nakamoto. 2008. *Bitcoin: A Peer-to-Peer Electronic Cash System*. Bitcoin.org. <https://bitcoin.org/bitcoin.pdf>.
- [112] Marcin Nawrocki, Matthias Wählisch, Thomas C. Schmidt, Christian Keil, and Jochen Schönfelder. 2016. A survey on honeypot software and data analysis. *eprint arXiv:1608.06249* (2016), 1–38.
- [113] Arash Nourian and Stuart Madnick. 2015. A systems theoretic approach to the security threats in cyber physical systems applied to stuxnet. *IEEE Trans. Depend. Secure Comput.* 99 (2015), 20.
- [114] NTTSecurity. 2016. *SERT Quarterly Threat Report Q2 2016*. Technical Report. NTTSecurity.
- [115] G. Odinet, M. A. Verhoeven, R. L. D. Pool, and C. J. de Poot. 2017. *Organised Cybercrime in the Netherlands*. Technical Report. The WODC (Research and Documentation Centre) of the Ministry of Security and Justice, 1–87.
- [116] Philip O’Kane, Sakir Sezer, and Kieran McLaughlin. 2011. Obfuscation: The hidden malware. *IEEE Secur. Priv.* 9, 5 (2011), 41–47.
- [117] Jeremiah Onaolapo, Enrico Mariconti, and Gianluca Stringhini. 2016. What happens after you are Pwnd: Understanding the use of leaked account credentials in the wild. In *Proceedings of the ACM SIGCOMM Conference on Internet Measurement Conference*. 1–15.
- [118] Hilarie Orman. 2013. The compleat story of phish. *IEEE Internet Comput.* 17, 1 (2013), 87–91.
- [119] Andy Ozment. 2004. Bug auctions: Vulnerability markets reconsidered. In *Proceedings of the Workshop on Economics of Information Security (WEIS'04)*. 1–23.
- [120] Pierluigi Paganini. 2016. Ran\$umBin a dark web service dedicated to ransomware. Retrieved from <http://securityaffairs.co/wordpress/46770/breaking-news/46770.html>.

- [121] N. Pavkovic and L. Perkov. 2011. Social engineering toolkit—A systematic approach to social engineering. In *Proceedings of the 34th International Convention on Information and Communication Technology, Electronics and Microelectronics*. 1485–1489.
- [122] Michael Porter. 1985. *Competitive Advantage: Creating and Sustaining Superior Performance*. The Free Press.
- [123] Rebecca S. Portnoff, Sadia Afroz, Greg Durrett, Jonathan K. Kummerfeld, Taylor Berg-Kirkpatrick, Damon McCoy, and Vern Paxson. 2017. Tools for automated analysis of cybercriminal markets. In *Proceedings of the World Wide Web Conference*. 657–666.
- [124] PwC. 2016. *Global Economic Crime Survey 2016: Adjusting the Lens on Economic Crime*. Technical Report. PwC. 1–31.
- [125] Bradley Reaves, Jasmine Bowers, Sigmund Albert, Gorski Iii, North Carolina, Olabode Anise, Rahul Bobhate, Raymond Cho, Hiranava Das, Sharique Hussain, Hamza Karachiwala, Nolen Scaife, Byron Wright, Kevin Butler, and Patrick Traynor. 2016. *Droid: Assessment and evaluation of Android application analysis tools. *Comput. Surveys* 49, 3 (2016), 1–30.
- [126] Bradley Reaves, Nolen Scaife, Dave Tian, Logan Blue, Patrick Traynor, and Kevin R. B. Butler. 2016. Sending out an SMS: Characterizing the security of the SMS ecosystem with public gateways. In *Proceedings of the IEEE Symposium on Security and Privacy*. 339–356.
- [127] Peter Reuter and Edwin M. Truman. 2003. Money laundering: Methods and markets. In *Chasing Dirty Money: The Fight Against Money Laundering*. Peterson Institute, 25–43.
- [128] Rick Holland. 2016. the hacker talent shortage: What organizations can learn from the recruitment efforts of their attackers. Proceedings of the <https://www.digitalshadows.com/blog-and-research/the-hacker-talent-shortage-what-organizations-can-learn-from-the-recruitment-efforts-of-their-attackers/>.
- [129] Rafael A. Rodríguez-Gómez, Gabriel Maciá-Fernández, and Pedro García-Teodoro. 2013. Survey and taxonomy of botnet research through life-cycle. *Comput. Surveys* 45, 4 (2013), 1–33.
- [130] Christian Rossow. 2013. *Using Malware Analysis to Evaluate Botnet Resilience*. Ph.D. Dissertation. Vrije Universiteit.
- [131] RSA Whitepaper. 2016. *2016: Current State of Cybercrime*. Technical Report. RSA. 1–7.
- [132] Ryan Ellis, Keman Huang, Michael Siegel, Katie Moussouris, and James Houghton. 2017. Fixing a hole: The labor market for bugs. In *New Solutions for Cybersecurity*, Alex Pentland, Howard Shrobe, and David Shrier (Eds.). MIT Press, 122–147.
- [133] Hamid Salim and Stuart Madnick. 2016. Cyber safety: A systems theory approach to managing cyber security risks—applied to TJX cyber attack. Cybersecurity at MIT Sloan, Working Paper, 1–17. <http://web.mit.edu/smadnick/www/wp/2016-09.pdf>.
- [134] Raj Samani and Francois Paget. 2013. *Cybercrime Exposed: Cybercrime-as-a-Service*. Technical Report. McAfee. 1–18.
- [135] Bruce Schneier. 2015. *Secrets and Lies: Digital Security in a Networked World*. Wiley.
- [136] Sebastian Schrittwieser, Johannes Kinder, Georg Merzdovnik, Edgar Weippl, and Stefan Katzenbeisser. 2015. Protecting software through obfuscation: Can it keep pace with progress in code analysis? *Comput. Surveys* 49, 4 (2015), 1–40.
- [137] E. J. Schwartz, Thanassis Avgerinos, and David Brumley. 2011. Q: Exploit hardening made easy. In *Proceedings of the USENIX Security Conference*, vol. 8. 25.
- [138] Offensive Security. 2017. Offensive security training, certifications, and services. Retrieved from <https://www.offensive-security.com/>.
- [139] Securityfocus. 2012. Payload Definition. Retrieved from <http://www.securityfocus.com/glossary/P>.
- [140] Dave Shackelford. 2015. *Combatting Cyber Risks in the Supply Chain*. Technical Report. SANS Institute, 1–20.
- [141] Wanita Sherchan, Surya Nepal, and Cecile Paris. 2013. A survey of trust in social networks. *Comput. Surveys* 45, 4 (2013), 47–47:33.
- [142] Sergei Shevchenko. 2016. Two bytes to \$951M. Retrieved from <http://baesystemsai.blogspot.com/2016/04/two-bytes-to-951m.html>.
- [143] Yan Shoshitaishvili, Ruoyu Wang, Christopher Salls, Nick Stephens, Mario Polino, Andrew Dutcher, John Grosen, Siji Feng, Christophe Hauser, Christopher Kruegel, and Giovanni Vigna. 2016. SOK: (State of) the art of war: Offensive techniques in binary analysis. In *Proceedings of the IEEE Symposium on Security and Privacy*. 138–157.
- [144] Johan Sigholm. 2013. Non-state actors in cyberspace operations. *J. Military Studies* 4, 1 (2013), 1–37.
- [145] Aditya K. Sood and Richard J. Enbody. 2013. Crimeware-as-a-service—a survey of commoditized crimeware in the underground market. *Int. J. Crit. Infrastruct. Protect.* 6, 1 (2013), 28–38.
- [146] Aditya K. Sood and Richard J. Enbody. 2013. Targeted cyberattacks: A superset of advanced persistent threats. *IEEE Secur. Priv.* 11, 1 (2013), 54–61.
- [147] Kyle Soska, Nicolas Christin, Kyle Soska, and Nicolas Christin. 2015. Measuring the longitudinal evolution of the online anonymous marketplace ecosystem. In *Proceedings of the 24th USENIX Security Symposium*. 33–48.
- [148] Melvin R. J. Soudijn and Birgit C. H. T. Zegers. 2012. Cybercrime and virtual offender convergence settings. *Trends Organ. Crime* 15, 2–3 (2012), 111–129.

- [149] Richard Spinello. 2016. *Cyberethics: Morality and Law in Cyberspace*. Jones & Bartlett Learning.
- [150] Oleksii Starov, Johannes Dahse, Syed Sharique Ahmad, Thorsten Holz, and Nick Nikiforakis. 2016. No honor among thieves: A large-scale analysis of malicious web shells. In *Proceedings of the World Wide Web Conference*. 1021–1032.
- [151] Steemit. 2017. theshadowbrokers. Retrieved from <https://steemit.com/@theshadowbrokers>.
- [152] William J. Stevenson. 2012. *Operations Management* (11th ed.). Tim Vertovec.
- [153] Brett Stone-gross, Ryan Abman, Richard A. Kemmerer, Christopher Kruegel, Douglas G. Steigerwald, and Giovanni Vigna. 2013. The underground economy of fake antivirus software. In *Economics of Information Security and Privacy III*. Springer, New York, 55–78.
- [154] Gianluca Stringhini, Oliver Hohlfeld, Christopher Kruegel, and Giovanni Vigna. 2014. The harvester, the botmaster, and the spammer: On the relations between the different actors in the spam landscape. In *Proceedings of the 9th ACM Symposium on Information, Computer and Communications Security*. 353–364.
- [155] Guillermo Suarez-Tangil, Juan E. Tapiador, Pedro Peris-Lopez, and Jorge Blasco. 2014. Dendroid: A text mining approach to analyzing and classifying code structures in Android malware families. *Expert Syst. Appl.* 41, 4, 1 (2014), 1104–1117.
- [156] Sufatrio, Darell J. J. Tan, Tong-wei Chua, and Vrizlynn L. L. Thing. 2015. Securing Android: A survey, taxonomy, and challenges. *Comput. Surveys* 47, 4 (2015), 1–45.
- [157] Kimberly Tam, A. L. I. Feizollah, N. O. R. Badrul Anuar, Rosli Salleh, and Lorenzo Cavallaro. 2017. The evolution of Android malware and Android analysis techniques. *Comput. Surveys* 49, 4 (2017), 1–41.
- [158] Digital Shadows Analyst Team. 2017. Innovation in the underworld: Reducing the risk of ripper fraud. Retrieved from <https://www.digitalsadows.com/blog-and-research/innovation-in-the-underworld-reducing-the-risk-of-ripper-fraud>.
- [159] Vrizlynn L. L. Thing, Henry C. J. Lee, and Morris Sloman. 2005. Traffic redirection attack protection system (TRAPS). In *IFIP Advances in Information and Communication Technology*, vol. 181. Springer, Boston, 309–325.
- [160] Kurt Thomas, Juan Antonio Elices Crespo, Ryan Rasti, Jean-Michel Picod, Damon McCoy, Lucas Ballard, Elie Bursztein, Moheeb Abu Rajab, and Niels Provos. 2016. Investigating commercial pay-per-install and the distribution of unwanted software. In *Proceedings of the 25th USENIX Security Symposium*. 721–738.
- [161] Kurt Thomas, Chris Grier, Justin Ma, Vern Paxson, and Dawn Song. 2011. Design and evaluation of a real-time URL spam filtering service. In *Proceedings of the IEEE Symposium on Security and Privacy*. 447–462.
- [162] Kurt Thomas, Danny Huang, David Wang, Elie Bursztein, Chris Grier, Thomas J. Holt, Christopher Kruegel, Damon McCoy, Stefan Savage, and Giovanni Vigna. 2015. Framing dependencies introduced by underground commoditization. In *Proceedings of the Workshop on the Economics of Information Security*. 1–24.
- [163] Kevin Townsend. 2017. Latest WannaCry theory: Currency manipulation. Retrieved from <http://www.securityweek.com/latest-wannacry-theory-currency-manipulation>.
- [164] Amit Kumar Tyagi and G. Aghila. 2011. A wide scale survey on botnet. *Int. J. Comput. Appl.* 34, 9 (2011), 975–8887.
- [165] Sun Tzu. 2005. *The Art of War*. Shambhala Publications.
- [166] Verizon. 2017. *2017 Data Breach Investigations Report*. Technical Report. Verizon.
- [167] John Wadleigh, Jake Drew, and Tyler Moore. 2015. The E-commerce market for “lemons”: Identification and analysis of websites selling counterfeit goods. In *Proceedings of the 24th International Conference on World Wide Web*. 1188–1197.
- [168] Wikileaks. 2017. Vault 7: CIA Hacking Tools Revealed. Retrieved from <https://wikileaks.org/ciav7p1/>.
- [169] Eric Wustrow and Benjamin VanderSloot. 2016. DDoSCoin: Cryptocurrency with a malicious proof-of-work. In *Proceedings of the USENIX Workshop on Offensive Technologies*.
- [170] Haitao Xu, Daiping Liu, Haining Wang, and Angelos Stavrou. 2015. E-commerce reputation manipulation: The emergence of reputation-escalation-as-a-service. In *Proceedings of the 24th International Conference on World Wide Web*. 1296–1306.
- [171] Michael Yip, Nigel Shadbolt, and Craig Webber. 2013. Why forums?: An empirical analysis into the facilitating factors of carding forums. In *Proceedings of the 5th Annual ACM Web Science*. 453–462.
- [172] Kim Zetter. 2014. A Google site meant to protect you is helping hackers attack you. Retrieved from <https://www.wired.com/2014/09/how-hackers-use-virustotal/>.
- [173] Mingyi Zhao, Jens Grossklags, and Peng Liu. 2015. An empirical study of web vulnerability discovery ecosystems. In *Proceedings of the 22nd ACM SIGSAC Conference on Computer and Communications Security*. 1105–1117.
- [174] Ziming Zhao, Mukund Sankaran, Gail Joon Ahn, Thomas J. Holt, Yiming Jing, and Hongxin Hu. 2016. Mules, seals, and attacking tools: Analyzing 12 online marketplaces. *IEEE Secur. Priv.* 14, 3 (2016), 32–43.

Received November 2017; revised March 2018; accepted March 2018

Supplementary Material for: Systematically Understanding the Cyber Attack Business: A Survey

KEMAN HUANG, MICHAEL SIEGEL, and STUART MADNICK, Massachusetts Institute of Technology

A NOTATION FOR THE CYBER ATTACK TARGET SELECTION RULE

For a rational cyber-attacker, a victim organization can be considered as a target if and only if the expected benefit B_e outweighs the expected cost C_e :

$$B_e = (P_e \times (B_{pm} + B_{pp}) \times E_r) > C_e = (C_{ps} + (P_a \times P_c \times C_c) + (C_{im} + C_{om})). \quad (1)$$

We summarize the notations as follows:

- P_e : Ease of the attack, represents how easy it is to performance the cyber attack;
- B_{pm} : Monetary benefit from a successful cyber attack against the target;
- B_{pp} : Psychological benefit from a successful cyber attack against the target;
- B_p : Potential benefit from a successful cyber attack; $B_p = B_{pm} + B_{pp}$
- E_r : Ease of benefit realization, represents how easily the attacker can realize the benefit, including both monetary and psychological benefit, from a successful attack;
- C_{ps} : Psychological Costs of the cyber attack for the attacker;
- P_a : Arrest rate, represents the risk of the attacker being identified and arrested for performing the cyber attack;
- P_c : Ease of the judicial process involved in the conviction;
- C_c : The opportunity cost if the attacker is convicted;
- C_p : The expected penalty cost $C_p = P_a \times P_c \times C_c$;
- C_{im} : The investment cost for the attacker to perform the cyber attack;
- C_{om} : The opportunity cost for the attacker to perform the cyber attack;
- C_o : The operational cost $C_o = C_{im} + C_{om}$.

B GLOSSARY FOR CYBERCRIMINAL SERVICE ECOSYSTEM

Table 1. Cybercriminal Services

<i>VDaaS</i>	Vulnerability Discovery as a Service
<i>EaaS</i>	Exploit as a Service
<i>EPaaS</i>	Exploit Package as a Service
<i>DaaS</i>	Deception as a Service
<i>PaaS</i>	Payload as a Service
<i>OBaaS</i>	Obfuscate as a Service
<i>SCaaS</i>	Security Checker as a Service
<i>RPaaS</i>	Repackage as a Service
<i>BNaaS</i>	Botnet as a Service
<i>TRaaS</i>	Traffic Redirection as a Service
<i>BHaaS</i>	Bulletproof Hosting as a Service
<i>TAaaS</i>	Traffic as a Service
<i>REaaS</i>	Reputation Escalation as a Service
<i>PPaaS</i>	Personal Profile as a Service
<i>DMAaaS</i>	Domain Knowledge as a Service
<i>TPaaS</i>	Tool Pool as a Service
<i>TSaaS</i>	Target Selection as a Service
<i>MLaaS</i>	Money Laundering as a Service
<i>MRaaS</i>	Money Mule Recruiting as a Service
<i>RaaS</i>	Reputation as a Service
<i>VEaaS</i>	Value Evaluation as a Service
<i>MPaaS</i>	Marketplace as a Service
<i>HTaaS</i>	Hacker Training as a Service
<i>HRaaS</i>	Hacker Recruiting as a Service

Table 2. Information for the Cybercriminal Service Ecosystem

<i>V</i>	Vulnerability	<i>V_p</i>	Operational Vulnerability
<i>V_t</i>	Technical Vulnerability	<i>T</i>	Target
<i>VEK</i>	Verified Exploit Kit	<i>E</i>	Exploit
<i>EK</i>	Exploit Kit	<i>FI</i>	Fake Information
<i>PL</i>	Payload	<i>SCSR</i>	Security Checker Report
<i>BN</i>	Botnet	<i>Z</i>	Zombie Machine
<i>BH</i>	Bulletproof Server	<i>TA</i>	Traffic
<i>GD</i>	Digital Gain	<i>GP</i>	Psychological Gain
<i>GL</i>	Monetized Forms of Benefit Directed from Attack	<i>HR</i>	Human Resource
<i>DK</i>	Domain Knowledge	<i>PP</i>	Personal Profile
<i>I_p</i>	Personal Information	<i>I_d</i>	Domain Specific Information
<i>M_C</i>	Legal Money	<i>M_D</i>	Illegal Money
<i>MLN</i>	Money Laundering Network	<i>HZ</i>	Manipulated/Tricked Human
<i>RR</i>	User Interaction Records	<i>R</i>	User Reputation
<i>VI</i>	Verified Information	<i>PG</i>	Good's Price
<i>CH</i>	Certificated Hacker with Necessary Skills	<i>NH</i>	Novice in the Hacker Community

Table 3. Tools for the Cybercriminal Service Ecosystem

<i>VDT</i>	Vulnerability Discovery Tool	<i>OBT</i>	Obfuscation Tool
<i>EKDT</i>	Exploit Development and Improvement Tool	<i>EDT</i>	Exploit Development Tool
<i>EPT</i>	Exploit Package Tool	<i>FDT</i>	Deception Development Tool
<i>PDT</i>	Payload Development Tool	<i>SCT</i>	Security Check Tool
<i>RPT</i>	Repackaging tool	<i>BNDT</i>	Botnet Development and Maintain Tool
<i>TRT</i>	Traffic Redirection Technique	<i>BHT</i>	Bulletproof Server Tool
<i>TGT</i>	Traffic Generate Tool	<i>RS</i>	Reputation Mechanism
<i>MDF</i>	Multi-modal Data Fusion Technology	<i>TMS</i>	Customization and Management Tool
<i>TS</i>	Training Support	<i>VES</i>	Value Verification Tool
<i>MMT</i>	Online Marketplace Development Tool	<i>HRT</i>	Hacker Recruiting Tool

C MAPPING BETWEEN THE VALUE CHAIN MODEL AND THE ECOSYSTEM FRAMEWORK

As shown in Figure 1, we map the services in the cybercriminal service ecosystem framework constructed in Section 3 to the value chain model presented in Section 2, and then we group the services into three different categories based on their availability:

- **Existing Services** refers to the existing services whose business model is not expected to change significantly in a short term.
- **Evolving Services** refers to the services which currently are available in the dark web but can evolve into a new service model due to technological development.
- **Emerging Services** refers to the services, though not observed as independent services yet but expected to emerge, due to their specialization and the existence of the similar innovations in legitimate businesses.

As summarized in Table 4, in the sections below we discuss each service's availability, pricing model, and some examples with their estimated price. Note that the prices do change over time, but the evolution of prices are one of our ongoing projects and out-of-scope in this article.

C.1 Existing Services

C.1.1 EaaS. Providing exploit as a service is one typical services for the cyber attack. Its price depends on its exploited vulnerability and can range from free to more than \$250,000. For example, a Microsoft Office zero-day vulnerability traded in a dark web market-TheRealDeal-on June, 2016 was priced at \$30,031 and a one-day vulnerability, including the exploit is about \$648.10. The zero-day exploit "iCloud reset mail Account Authentication Elevation of Privilege 0day Exploit" from oday.today, was priced at \$4,500 on November, 2017 [36].

C.1.2 PLaaS. For the payload, the price can go up to thousand U.S. dollars based on its efficiency. For example, GandCrab, a ransomware discovered in Jan 2018, demands payment using the cryptocurrency Dash, which converts to about \$1,200 [10].¹ In addition, the pay-per-install (PPI) has risen to predominance for payload services, in which the miscreants were charged based

¹The prices of crypto currencies have been changing rapidly.

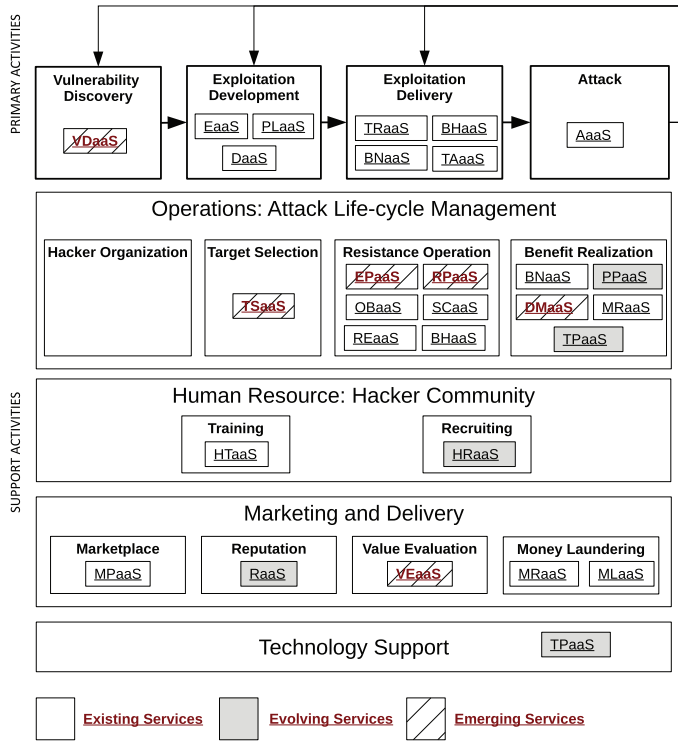

Fig. 1. Mapping between the ecosystem framework and the value chain model to understand the development of the cybercrime services.

on the number of victim systems [15, 78], with around \$0.02–\$0.10 per install. The GandCrab even offers a partner program, in which members share 40% profits to the developers.²

C.1.3 DaaS. The phishing service is a typical demonstration of “DaaS,” which includes four different components: an SMTP server, priced \$15–\$30, to relay phishing emails; automated mailer applications to send emails, priced \$20–\$25; fraudulent websites, priced \$15–\$20; and high-quality email lists of individuals and businesses, priced \$35–\$40. This reveals that the estimated price for the phishing service will demand \$85–\$115 [72]. For the fake anti-virus, the victim will typically pay between \$50 and \$100, while the buyers will share about 40% commission with the sellers [49].

C.1.4 OBaaS. The obfuscation service makes it difficult for the anti-virus software to detect the cyber attacks by making it hard to understand the program logic without affecting the execution behaviour. On average, the obfuscation services will cost \$50–\$150 per subscription and for the file-stitching service style, the price can range from \$5–\$30 per file.

C.1.5 SCaaS. Providing the “security checking” platform for testing, similar to the emerging mobile app testing cloud in mobile ecosystem [30], can increase the succeed rate of cyber-attacks. One typical SCaaS is the Scan4you, which “help[s] you in anonymous check[ing] of different

²<https://www.scmagazine.com/researchers-uncover-russian-dark-web-ad-for-new-gandcrab-ransomware-as-a-service/article/741771/>.

Table 4. Status and Typical Pricing of Cybercrime Services Actual examples for existing services, emerging and evolving services are based on offensive versions of actual legitimate services

	Status	Pricing Model	Example Case	Estimated Price
EaaS	Existing	License	Exploit Trading [36]	up to more than \$250, 000
		Subscription	Up-to-date Zero-day Exploits [74]	\$150, 000 per month
PLaaS	Existing	Pay-per-install	Payload Renting [10, 15]	\$0.02–0.10 per install
		Commission		40%
DaaS	Existing	Subscription	Phishing Service [72]	\$85–\$115 per month
		Commission	Fake Anti-virus [49]	40%
OBaaS	Existing	Subscription	Obfuscation Platform [31]	\$50–\$150 per month
SCaaS	Existing	Subscription	Scan4you [39]	\$25 per month
TRaaS	Existing	Pay-per-click	Traffic Redirection [31]	\$7–\$15 per 1, 000 visitors
BNaaS	Existing	Subscription	Botnet Shops [72]	\$40 per month
BHaaS	Existing	Subscription	Cloud Bulletproof Servers [52]	\$300 per month
TAaaS	Existing	Subscription	DDoS Attack Service [67]	\$999 per month
REaaS	Existing	Pay-per-record	Reputation Escalation Markets [87]	\$0.4–\$0.7 per record
MPaaS	Existing	License	Market Framework [24]	\$4, 500 per licence
		Commission	Marketplace [23]	2%–10%
MRaaS	Existing	License	Money Laundering Recruitment Package [51]	\$1, 700 per licence
MLaaS	Existing	Commission	Money Laundering Service [62]	2%–30%
HTaaS	Existing	License	Hacker Training Courses [69]	\$250–\$800 per person
PPaaS	Evolving	License	Personal Profile Investigator [33]	\$4–\$20 per record
TPaaS	Evolving	Subscription	“One-stop-shop” Platform [1, 42]	\$4, 000 per month
RaaS	Evolving	Subscription	Smart Contract [43]	/
HRaaS	Evolving	Subscription	Online Hacker Recruiting Market [54]	/
VDaaS	Emerging	Subscription	Bug Bounty Program [64]	\$542.04–\$1, 810.31 per vulnerability
TSaaS	Emerging	Subscription	Targets Ranking based on Value [53]	/
EPaaS, RPaaS	Emerging	Subscription	Repackaging Platform [71, 74]	\$4, 000 per month
DMaaS	Emerging	Subscription	“How-to” Knowledge Systems [19]	/
VEaaS	Emerging	Subscription	Comparison “Shopping” Service [32]	/

It is important to realize that the cybercrime ecosystem is constantly evolving and the pricing models and prices even more so. The prices listed in our table are intended to be representative of current prices.

anti-virus system” [39].³ It offers three different service package: \$25 per month, or \$3 per day, or \$0.15 per check. Note that SCaaS can also be very expensive. For example, it is believed that for the Ukrainian power grid attack, the attacker built a simulated power grid system similar to the Ukrainian power grid plant so that they were able to evaluate and test the developed firmware prior to the attack [26]. In this case, the price for this service, if available, would be much higher.

C.1.6 TRaaS. The “*traffic redirection*” service is used to redirect the visitors to a particular website via a traffic direction system. Normally, it costs only \$7–\$15 for 1,000 visitors [31].

³The service’s website “<http://scan4you.net>” is no longer available since 2018. However, the reference provides the screen shots for this service.

C.1.7 BNaas. The underground sellers can control the botnet and then the buyer can rent the C&C panel through the bot shops [72]. Typically, a bot net consisting of 4,000 machines cost only about \$40.

C.1.8 BHaaS. The bulletproof servers play an important role in cybercriminal operations. Their prices depend on the risk involved in the contents. For low-risk content like shopping sites for fake goods, a bulletproof server will only cost \$2 per month while high-risk content like exploits, malware etc. will cost about \$300 per month [52] for a dedicated server. In addition, hackers even offer cloud-style “bulletproof servers” on the dark web to tap into the benefit of cloud computing [7] and their price will depend on the cloud-hosting service.

C.1.9 TAaaS. The typical scenario for TAaaS is the well-known DDoS attack. Normally, a DDoS attack service will cost the buyer \$25 per hour and nowadays, most DDoS attack services are served in a subscription style. According to Reference [67], the “Brilliant” package, consisting of “a DDoS bot, lifetime free updates, unlimited free rebuilds, all modules for free, 25% discount on other products like sources, web-panel reinstalling, etc.,” was priced with \$999 per month. A DDoS attack service, CoalaBot, discovered in September 2017, went for only \$300 per month [41].

C.1.10 REaaS. The Blackhat search engine optimization (SEO) services, which is a low-price example of typical reputation escalation services, can be used to promote websites and optimize for searches. For example, the consumer only needed to pay \$140 to get 1,000 Facebook Likes [31] in 2012. In addition, the research about five seller reputation escalation markets, including SKY, WOOD, EMPIRE, COOL, and NET, reveals an average price of \$0.4–\$0.7 per express tracking label in 2015 [87].

C.1.11 MPaaS. The marketplace is a fundamental component serving as the trading place to realize the benefit from the cyber attacks [23]⁴ and the market runner will charge 2%–10% commission for each transaction. Some marketplaces may require vendor bond or are available only by invitation to enhance the market’s reputation. In June 2017, a black market framework for buyers to build their own darknet marketplace was offered as “platform-as-a-service” to sell licenses at a price around \$4,500 in Bitcoin [24]. Professional services to customize the markets were also provided depending on the customer needs.

C.1.12 MRaaS. Money mule recruitment services are provided to help cybercriminals achieve faster recruitment rates via a complete mule recruitment template package, including “a back-end administration system, website template, spam e-mail templates, mule correspondence templates and more” [51]. In 2009, such standard money mule recruitment services were offered for \$900 and the corporate version, with additional features like multi-language support, fake signatures representing the CEO, domain hosting management, and so on, goes for \$1,700.⁵

C.1.13 MLaaS. Once the money mules are recruited to join the money laundering network, they are offered around \$870 per week and a small commission, normally 2–5%, for each transaction. However, according to Reference [62], the total cost of using laundering service ranges from 5%–10% commission. Specifically, Ran\$umBin, a money-laundering service discovered in April 2016, operates a one-stop shop for monetizing ransomware. The business model is quite simple: the attackers pay the service provider \$100 and a 30% commission, and then the service provider guides the victim to pay the ransom [60].

⁴Deep.Dot.Web maintains a list of dark net markets. For the last update on February 3, 2018, it includes 32 live markets and vendor shops.

⁵<https://ddanchev.blogspot.com/2009/10/standardizing-money-mule-recruitment.html>.

C.1.14 HTaaS. For the basic form, HTaaS offers step-by-step guides, tutorials, or online school like OnionIRC [29], which can be offered at a very low price (around \$50 or even for free). For example, “The OnionIRC network” was launched by Anonymous to educate beginners with advanced free courses about pen-testing, security, hacking, social engineering, or others. However, many ethical hacker training courses offer not only lectures about attack technologies but also hands-on lab exercises, with prices ranging from \$250 to \$800 [69].

C.2 Evolving Services

C.2.1 PPaaS. For the “*personal profile*” services, a typical service offers personal account information, like email account, driver license, passport, and so on, at a very low price. For example, the price for an European passport is about \$5 [31] and a pharmacy customer database with more than 50,000 emails was sold in dark web-RealDeal-for no more than \$1000 on June, 2017. The estimated price per credit card is related to the credit card’s value, which can range from \$4 to \$20 [33]. However, the available data from data breaches and social media, as well as the development of the multimodal data fusion techniques, will further enable new services that will offer value-added information, like comprehensive personal profile, on the given targets when requested. Consider the analogy of private investigators, who run a legitimate business: their fees range from \$40 to over \$100 per hour, and average around \$50 an hour in the United States.⁶

C.2.2 TPaaS. “*Tool-kit platforms*” will emerge to collect the hacking tools, especially those developed or customized by highly skilled hackers or nation-supported hacker organizations, and make them available in a “one-stop-shop” style [1, 12, 79, 88] to enable more destructive attacks. The Adwind [42], a typical TPaaS example, was distributed via a software-as-a-service platform based on an online subscription model in 2015. The price for a one-month membership is \$4,000 and it offers different standalone components as a service. “TheShadowBrokers Monthly Dump Service” in October 2017 requests 500ZEC, equal to about \$150,000. Currently, these tools are sold as independent components and it is very likely that in the future, this platform-style service may even integrate different available components for more complex attacks, serving the “cybercriminal service composition as a service.”

C.2.3 RaaS. As discussed before, the dark web marketplaces offer reputation mechanisms, like offering user feedback or providing a certain vendor bond, to mitigate the uncertainty associated with dealing with users who hide their true identities. In addition, some third-party services maintain databases of rippers [77], or use relationships based on real-world social networks [46], to enhance the reputation evaluation. Beside these, to address this critical issue for the underground economy, we can expect new “*Reputation mechanism*” like smart contract based on blockchain technology [43, 86] or cyber grand challenge [9] could be further developed to mitigate the uncertainty.

C.2.4 HRaaS. Cybercriminals may need to recruit additional hackers to collaborate with or work on a particular attack. “Rent-a-Hacker” [80] has been proven to provide good-quality hacking services with a lot of positive customer feedback. According to the service description, it can do different hacking tasks, including “ruining people, espionage, website hacking or DDoS attack, etc.,” with prices ranging from \$300 to \$1,400. In addition, most hackers-for-hire can be found on Reddit-like forums and are hired to perform specific cyber attacks with bounties up to \$2,000 [84]. However, similar to the legitimate online labor market services, like Glassdoor [54], we can expect

⁶<https://www.angieslist.com/research/private-investigator-services/>. Last visited on February 6, 2018.

such online hacker labor market in the near future, if it does not exist yet, to become available to facilitate the hacker recruitment.

C.3 Emerging Services

C.3.1 VDaaS. Due to the high uncertainty for vulnerability discovery, we have not observed instances of vulnerability discovery services in the dark web during our research. However, it is possible that we will observe similar applications in the dark web, inspired by the rapid growth of the bug bounty program platforms, to take advantage of knowledge from the whole hacker community for a targeted cyber attack. Additionally, services that can dig into the operational vulnerabilities [58, 65, 66] could emerge and prove attractive to attackers. Intuitively, the price for VDaaS will depend on the value of discovered vulnerabilities, which has a very large price range. According to Reference [64], the average bug bounty for a valid discovered vulnerability is \$542.04 on HackerOne, while for the Facebook bug bounty program, it is about \$1,810.31.

C.3.2 TSaaS. Given the rapid growth of the targeted cyber attack [47, 53, 73], targets ranking based on value can spread to, and prove popular, in the dark web, as it can help the attackers significantly reduce the target searching process and increase the potential benefit from the successful attack. However, given its basis of intelligence sharing, it is very likely that this service, if it exists, will be provided as a subscription-based service or as a special membership benefit.

C.3.3 EPaaS and RPaaS. “Repackaging” to produce a verified exploit kit, including the EPaaS and RPaaS, requires specific skills and recently most attackers are performing by themselves. However, as technology develops, it is reasonable to expect that cybercriminals will offer platforms or related tools to help the repackaging attacks more effectively [8, 13, 71]. Currently, this repackaging-style service is integrated as a part of the exploit kits. For example, the Neutrino exploit kit, which was a favorite tool among cyber-criminals between June and September 2016, contained five different exploits and a user-friendly control panel to make it easy to use. The price was \$1,500 per week, or \$4,000 per month, in June, 2016 [40].⁷

C.3.4 DMaaS. For “domain knowledge” services, the most likely services we may expect to observe would resemble the “how-to” knowledge systems similar to the emerging online platforms like WikiHow, eHow, and Howcast [19].

C.3.5 VEaaS. Many comparison shopping websites [32] help the customers filter and compare products based on price, reviews, and other criteria. It can be expected that similar “valuation” services will emerge on the dark web to help cybercriminals choose the most reliable components and to help sellers competitively price their goods. Similar to TSaaS, it is very likely that this type of service, if it exists, may be provided as a subscription-based service or as a special membership benefit embedded within the dark web marketplace.

D CYBERCRIMINAL THREAT DEVELOPMENT

To evaluate whether the presented framework can usefully describe the cybercriminal ecosystem and serve as a tool to study evolving cyber threats, we consider the cyber threats discussed in the McAfee Labs 2017 Threats Prediction report [53] as an example. This McAfee report proposes 14 predictions for cybersecurity developments in 2017. Not all predictions are related to cyber-attacks, and we only consider those related to cybercrime, mapping them into the presented framework to understand the cyber-threats they pose, and graphically represent these cases in Figure 2. Those

⁷For more details about Neutrino’s life-cycle, please check this website: <https://www.bleepingcomputer.com/news/security/former-major-player-neutrino-exploit-kit-has-gone-dark/>.

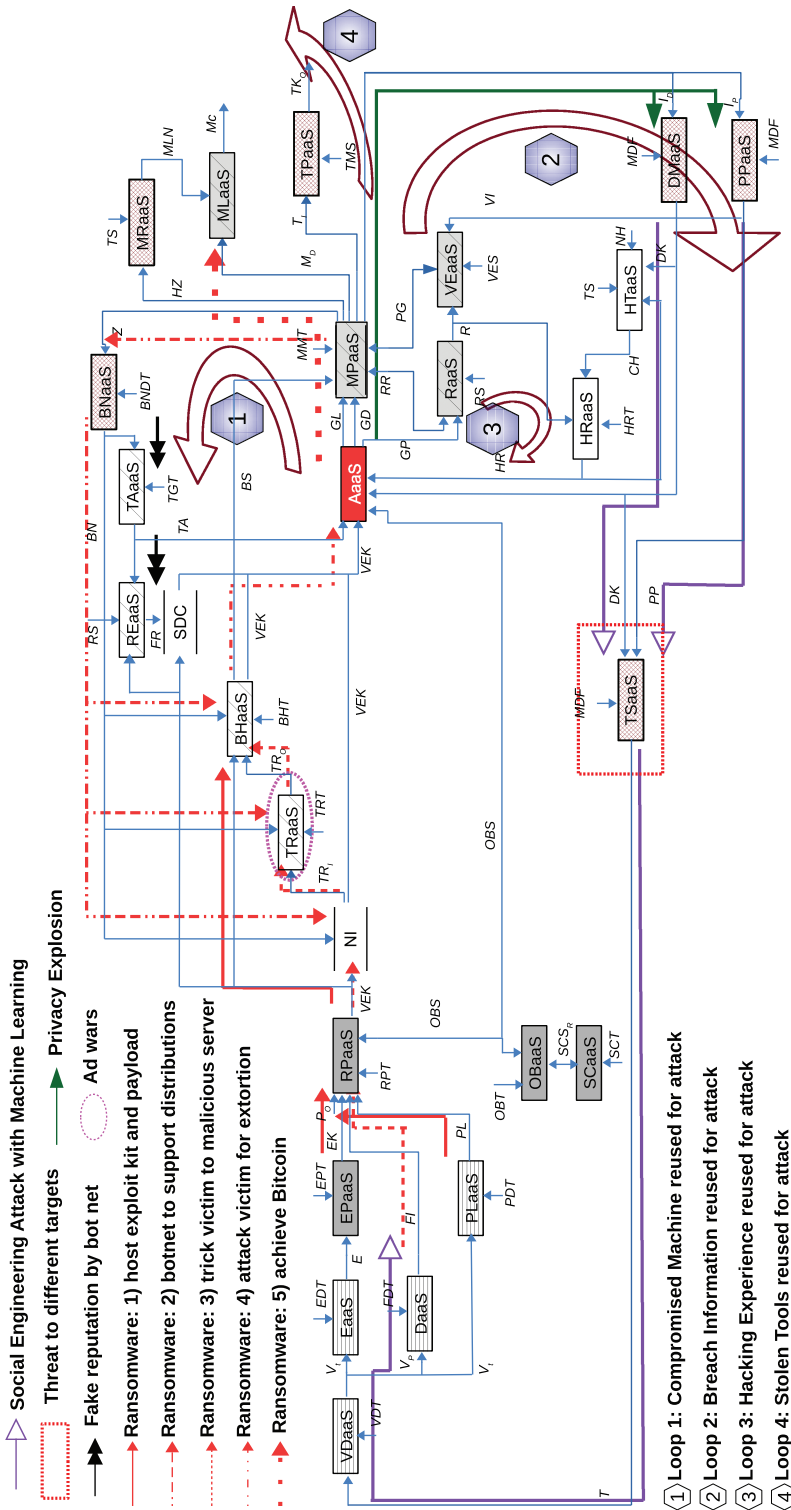

Fig. 2. Systematic Understanding of Cyber-threats. Using the predictions from the McAfee Labs 2017 Threats Prediction Report, we map the identified threats into the framework which forms two reinforcement loops including the reuse of the compromised machines and the breach information. Furthermore, based on the framework, we can also observe two other loops including the hacking experience and the stolen tools for further cyber attacks.

that are particularly related to the potential defense efforts, such as “*Leveraging increased cooperation between law enforcement and industry, law enforcement takedown operations will put a dent in cybercrime*” or “*Threat intelligence sharing will make great developmental strides in 2017,*” are not included in the following discussions.

- **Ransomware Attacks, especially to compromise business processes.** Ransomware attacks continue to pose a significant threat. Often, the victim of a ransomware attack is redirected to a server where an exploit kit, such as RIG or Neutrino, is hosted. The exploit kit capitalizes on vulnerabilities in the victim’s systems to install a downloader, opening the door for the attacker to activate a ransomware payload like Wana Decrypt0r, Locky, or CryptoWall to lock the victim’s computer and compromise the business continuity of the victim’s operations. It can be seen that this threat follows a path in our framework involving EPaaS (exploit package), DaaS (fake information), PLaaS (payload), RPaaS (repackage), TRaaS (traffic redirection), BHaaS (bulletproof server), BNaaS (bot net), AaaS (multi-step attack), MPaaS (marketplace), and MLaaS (money laundering).

- **Social engineering attacks accelerated by machine learning.** With greater accessibility to machine learning technology, the FBI-labeled Business Email Compromise (BEC) scam [50], in which the scammers target employees with access to company finances and trick them into making wire transfers to bank accounts thought to belong to trusted partners, has become much more prevalent due to the available information to manipulate the target’s perception. Based on data gathered from data breaches, social media, public disclosures, as well as domain knowledge, cybercriminals can train a model to identify valuable targets, and then generate convincing fake messages for a semantic social engineering attack. This threat begins at PPaaS (personal profile), and DMaaS (domain knowledge), makes use of TSaaS (target selection) and VDaaS (vulnerability discovery) to identify the operational vulnerability in the specific targets. Finally relies on the DaaS (fake information) to generate persuasive but fake message for the attack.

- **Fake reputation generation by botnet.** Reputation systems are an important component of any digital community. Due to the vulnerabilities inherent in a reputation system, services to falsify a user’s reputation are available and growing in scope. To support this activity, a botnet, possibly constructed by infected machines, or physical servers located in data centers, can be used to generate fake clicks or comments that increase a user’s online notoriety. This attack represents the application of the online traffic, involving BNaaS (botnet), TAaaS (traffic), and REaaS (reputation escalation).

- **Ad wars technology to boost malware delivery capabilities.** Advertisers display ads in hopes that a user will click on them. Once the ad is clicked, a user profile is generated that allows for targeted advertisements and greater revenue for advertisers. This technology will likely be used by cybercriminals to redirect traffic to a compromised website, representing the recent growth of TRaaS (traffic redirection).

- **Privacy explosion by hacktivists.** The data breaches are expected to increase, targeting some of the corporate clouds that contain customer data. Cybercriminals can profit from stolen data, meaning that PPaaS (personal profile) will become more accessible.

- **Cyber threats to hardware, firmware, drone, the mobile ecosystem, and IoT increase while attacks on Windows subside.** This threat prediction discusses cyber threats to different targets with different technical environments, which is related to the TSaaS (target selection).

As reported in Figure 2, these threats can be mapped into our framework. Hence, the presented ecosystem model can serve as a tool, allowing us to think systematically about the evolution of cyber-threats. More importantly, these threats are not independent. In fact, they form reinforcement loops, including the reuse of compromised machines, stolen tools, stolen information, and the hacking experience, through which each threat reinforces and empowers the others. Note that

the McAfee report does not consider many components related to cybercrime support activities, although we understand them to be very important in the systematic understanding of cyber-threat evolution. For example, understanding OBaaS (obfuscation) [68] will be critical to security software providers as they prepare for the attacks. The development of the money-laundering network driven by the use of digital currency in the cybercrime ecosystem [14] will also change approaches used in benefit realization.

E THE RETURN-ON-INVESTMENT FOR THE RANSOMWARE ATTACK BUSINESS

To analyze the profitability of cybercriminal businesses, as shown in Figure 3, we use the ransomware attack as an example. The price of each involved service is based on the observed instances in the dark web, which is discussed in Section C. To calculate benefit, we use the indicators from the Angler revenue reported by Cisco [20] as a baseline but make a much more conservative estimate acknowledging the defensive efforts.

• **Costs of sample services.** To run a ransomware attack as a business, a cybercriminal can buy BNaaS (botnet) for \$999 per month, a traffic redirection protocol for \$600, six servers as a part of BHaaS (bulletproof server) for \$1,800 per month, access to the Neutrino exploit kit in EPaaS (exploit package) for \$4,000, a ransomware payload with customer support in PLaaS (payload) for \$3,000, and the traffic redirection service TRaaS used to redirect victims to servers for \$600 per month. To further increase the effectiveness of an attack, a cybercriminal can hire a qualified hacker from HRaaS for \$2,000 per month and employ an obfuscation service from OBaaS to repackage the exploit kit and payload for \$600 per month. Finally, to reduce risk of arrest, services to monetize benefits in the wake of a cyber attack as a part of MLaaS (money laundering) can be accessed for a fee of \$400 and a 40% commission on processed funds.

• **Example of Return on Investment (ROI).** For calculating benefit, we assume that 30,000 people are redirected per day, of which 10% are victims of a ransomware attack where 0.5% of victims pay a \$300 ransom. Though only 450 victims (0.05% of total users redirected) will end up

Cost (\$/m)		Benefit (\$/m)	
BNaaS	999	Redirected User (Daily)	30k/d
BHaaS	1800	Redirected User (Month)	900k/m
EPaaS	4000	Success Rate	10.00%
PLaaS	3000	Pay Percent	0.50%
TRaaS	600	Pay Number (Angler Report)	450/m (9,515/m)
HRaaS	2000	Ransom Money	300
OBaaS	600		
MLaaS	400(+40%)		
Total Cost	13,399(+40%)*	Total Benefit (\$/m)	81,000 (1712,700)
		Net-Benefit (\$/m)	67,601 (1,699,301)
		ROI	504.52% (12,682.30%)

Fig. 3. ROI for the Ransomware Attack Business: Value of the cybercriminal service composition. Italics with blue color indicates that the monetization service requests 40% commission from the benefit the attacker gains. Bold with red indicates the number of victims who pay the ransom from Angler Revenue Report [20] is used. In this case, the ROI (12,682.30%) is much higher than the best performing company, Cheniere Energy Partners Lp Holdings, Llc (7020.69%) in August 2017 reported by CSIMarket [22].

paying the ransom over a period of one month (30 days), this brings the cybercriminal’s monthly earnings to \$135,000. We can see that the Return-On-Investment (ROI), even when only a small proportion of people end up paying a ransom, is as high as 504.52%, an impressive ROI for any business. Using the reports from CSIMarket [22] for comparison, the highest industrial ROI, which is from the Tobacco industry, was only 50.63% in August 2017; in fact, this theoretical cybercrime operation would be ranked as one of the top seven best performing companies in the world in terms of ROI. If we use the numbers from the Angler revenue report, which shows that 9,515 users pay the ransom per month, a number over 20 times larger than our assumed 450, then the ROI of this operation would be 12,682.30%, which is significantly higher than the highest ROI from Cheniere Energy Partners Lp Holdings, Llc (7020.69%) in August 2017.

• **Cybercriminal service composition as a service.** Hence, we can conclude that combining separate services to perform a cyber attack is extremely valuable to cybercriminals. This motivates the emergence of “*cybercriminal service composition as a service*.” In this scenario, the attacker can apply services available on multiple dark web marketplaces and combine them to offer a “one-stop shop”-style service, which will reduce the barriers to entry of cybercrime and performing complex cyber-attacks. More importantly, this development also allows cybercriminals involved in the cybercrime ecosystem to specialize, focusing on the parts of the value chain model at which they are best, and provide their expertise as a service to other cybercriminals. Following this “specialization, commercialization, and cooperation” trend, cybercriminals may be able to hide themselves even deeper in the dark web. In certain cases, some of their activities may no longer be characterized as illegal.

F UNDERSTAND A SPECIFIC CYBER ATTACK INCIDENT

Armed with an understanding of the value-added processes for a cyber-attack, the cybercriminal service ecosystem, we can begin to think about what the next steps of a cyber-attack could be. As an example of a next step, we consider the May 12, 2017 WannaCry Hurricane that hit more than 200,000 computers around the world, as diagramed in Figure 4.

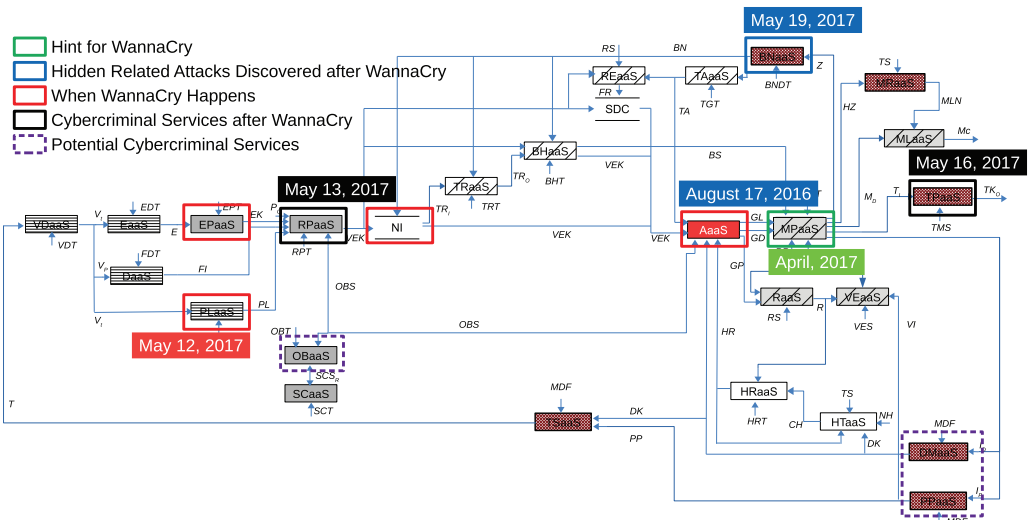

Fig. 4. Understand WannaCry cyber attack evolution using the cybercriminal service ecosystem framework.

In April 2017, hacking tools stolen by a group called “The Shadow Brokers” during an August 2016 attack on the National Security Agency (NSA), became available on dark web marketplaces.⁸ On May 12, 2017, the WannaCry Hurricane attack used EternalBlue and DoublePulsar tools to compromise its victims’ computers and automatically infect neighboring machines. To solve the “kill switch” issue, some hackers further repackaged the WannaCry payload to create new variants by the next day. Given the huge impact of the attack, the Shadow Brokers published a statement on May 16, 2017, announcing that they would release more zero-day vulnerabilities and exploits starting in June 2017, and that they would be offering a subscription-based service, “TheShadow-Brokers Dump Service,” with access to up-to-date exploits. After the WannaCry attack, security researchers found that several hacking groups and individual hackers had already used the tools to build a botnet and collect credentials which could be dated as stolen as far back as April 2017, but that had not been detected as compromised before then.⁹

As shown in Figure 4, by thinking about this attack through the lens of the framework, it can be seen that these activities are all included in the framework and follow the value-added processes. In fact, following the framework, we can expect more stolen tools to be offered as TPaaS, more payloads and obfuscation strategies will emerge with PLaaS and OBaaS, respectively, and, with collected credentials and domain-knowledge, PPaaS and DMaaS will become more active.

G COMBATING CYBERCRIME: STRATEGY IMPLEMENTATION EXAMPLES

G.1 Striking the Dark Side: Identifying Control Points to Improve Effectiveness

To understand the dark web itself is a step in the right direction in the effort to stymie the growth of the underground cybercrime ecosystem; however, this is more easily said than done, as collecting data on dark web activity proves difficult [34]. The “honeypot”¹⁰ is a technology to detect, deflect, or counteract attempts to use information systems in an unauthorized way, and many honeypot systems have been used to reveal information from how and why cybercriminals intrude into certain systems, to which threats exist or are developing in the wild [3, 16, 57]. The Telekom-Fruhwarnsystem project [57] was launched in 2013 to establish a worldwide multi-honeypot platform to collect unbiased quantitative data that would present a realistic picture of internet threats. The data the system collects is related to the attack profile and describes the attack’s sources, vulnerabilities it exploits, tools it employs, and level of sophistication. The HoneyCirculator monitor system behaves like a compromised system to collect malware, bait credentials, fraudulent link, and compromised web content [3]. It can be seen that these honeypots are purposefully planted in certain corners of cyberspace to target certain cybercriminals, as described by AaaS (multi-step attack). Some researchers have also tried to understand exactly what goods are traded on the dark web [4, 18, 35, 88], focusing on MPaaS (marketplace).

Based on the presented cybercrime ecosystem framework, if we can rig the important control points in the cybercrime ecosystem with “honeypots,” representing the value-added paths of the cyber-threat supply chain, we can achieve a better understanding of the underlying economy of cybercrime and profile, which has until now been the “dark side” of a cyber attack. Inspired by

⁸The “Shadow Brokers” put the stolen cyber weapons on auction at the beginning. After the auction failed, they moved to sell the tools directly to buyers one by one. In April 2017, the group publicly released seven exploits in the dark web.

⁹Please check this link for more details: <http://thehackernews.com/2017/05/wannacry-ransomware-cyber-attack.html>. In addition, please check this website for more posts from The Shadow Brokers: <https://steemit.com/@theshadowbrokers>. Last visited on February 6, 2018.

¹⁰Generally, a honeypot consists of data (for example, in a network site) that appears to be a legitimate part of the site, but is actually isolated and monitored, and that seems to contain information or a resource of value to attackers, who are then blocked. This is similar to police sting operations, colloquially known as “baiting,” a suspect. Please refer to [https://en.wikipedia.org/wiki/Honeypot_\(computing\)](https://en.wikipedia.org/wiki/Honeypot_(computing)) for more details about honeypot.

Reference [21], we can define the control point as the critical components that can support the other components in the cybercriminal service ecosystem.

Definition: Control Point Services. A cybercrime service is considered a control-point service, if and only if its output can be the support for another service.

Hence, as shown in Figure 5, it can be seen from the framework that the followings are control-point services in the cybercriminal service ecosystem:

- OBaaS (obfuscation), work with SCaaS (security checker) to circumvent detection, which can bypass the effort from defensive side to improve the success rate for a cyber attack.
- BHaaS (bulletproof server), offers bullet-proof server access to improve the resilience of the underground economy.
- HRaaS (hacker recruiting), recruits hackers to join the cybercriminal ecosystem or participate into a cyber attack.
- BNaaS (botnet), provides botnets to support numerous components in the ecosystem, which is a fundamental infrastructure for the cybercriminal ecosystem.
- MRaaS (money mule recruiting), constructs the money laundering network to convert illegal money into legal money, acting as the connection between the underground economy and legitimate businesses.
- DMaaS (domain knowledge), yields necessary domain knowledge, PPaaS (personal profile) reveals personal information, and TPaaS (tool pool) offers tools that support other activities.

If the defense side can build “honeypot”-style services for these control points, it can help the cybersecurity community, the defensive side, to understand and monitor the evolution of the cybercrime ecosystem more effectively. For example, the infrastructure developed by Onalapo et al. [59], which plants a honeypot in the PPaaS, can be used to monitor how compromised Gmail accounts are used on the dark web. This research reveals that cybercriminals tend to evade security mechanisms employed by online services meant to flag suspicious logins and proposes a behavioral model based on the contents of search queries that could signal malicious activity. Taking down these control point components, especially the reuse-related components, including BNaaS, DMaaS, PPaaS, TPaaS and MRaaS, can also help to break the reinforcement loops in the cybercriminal ecosystem.

Furthermore, such a scheme could also help law enforcement collect critical evidence to convict cybercriminals and strike at the heart of cybercrime business. More interestingly, given the uncertainties related to identity and quality, the cybercriminal market is a typical “market for lemons” [55, 82, 83]. If the defensive side can flood the cybercriminal ecosystem with honeypot-style or fake goods, it will make the dark web less attractive to cybercriminals looking to purchase services. Consider the following successful example: When the dark web marketplace AlphaBay was closed and the servers for Hansa, another dark web marketplace, was seized by the government, they continued to run Hansa for a month to collect information about the vendors and customers [28]. This strategy, running Hansa under control, further raised concerns for the hacker community that other dark web markets, such as Dream market, were also compromised in a similar manner and under police control.

Finally, the framework can also be used to access the effectiveness and side-effects for the cybersecurity policies. For example, from the control point analysis, we can observe that HRaaS (hacker recruit) also serves as a control-point for the cybercriminal ecosystem, which can be considered a pipeline to recruit the cybersecurity workforce into the offensive side. Without considering the impact from HRaaS, which recruits skilled workforces to involve into the cyber attack ecosystem, the efforts to improve the cybersecurity workforce supply by offering related training [25] will also increase the cybercriminal workforce supply.

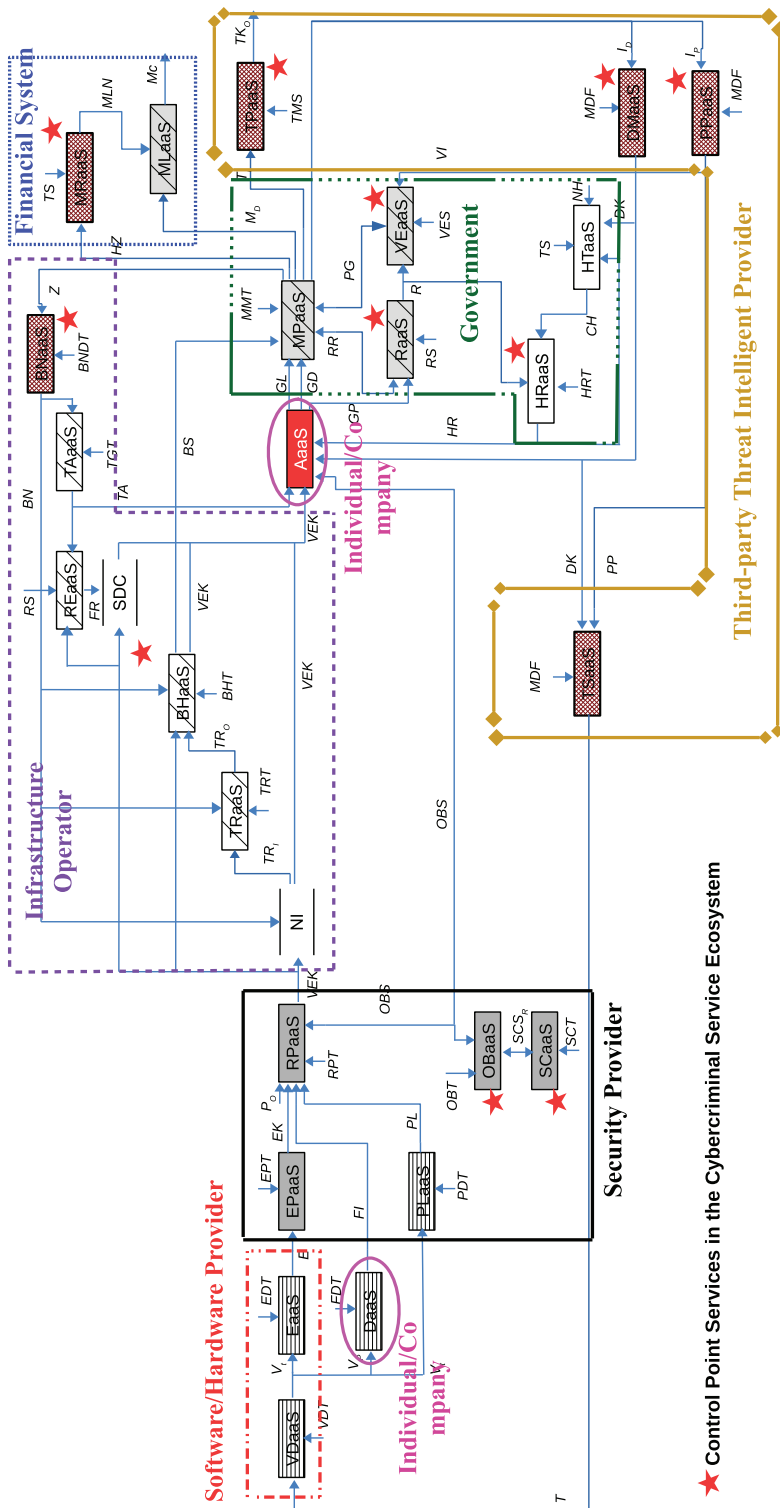

★ Control Point Services in the Cybercriminal Service Ecosystem

Fig. 5. Responsibility Allocations between the individual/Company, security provider, infrastructure operator, government, financial system and third party threat intelligent provider as well as the identified control-point services which can support the other services in the cybercriminal service ecosystem.

G.2 Sharing Responsibility: Action Suggestions for Better Collaboration

There exist several challenges plaguing cybersecurity and cybersecurity policy when it comes to working together to build a safer, connected world [55]: the externalities [44], the misaligned incentives [6], and the information asymmetries [5]. These market failures call for implementation of policies to allocate responsibilities to different parties so that cybersecurity can be improved in the places where economic forces disincentivize it. Given the presented cybercrime ecosystem framework, as reported in Figure 5, we can identify which responsibilities or actions fall to which actors based on whether the actors have the capability to take the actions:

- *Individuals and Corporations* have a responsibility to protect themselves by investing in security software or hardware, altering processes, or educating people on common cyber-attacks. Defenders are also responsible for sharing cyber risk information. However, designing effective mechanisms to motivate the information sharing while bypassing its negative effort is still an open but challenging issue [17, 45, 48, 85].
- *Software/Hardware Providers* have a responsibility to monitor vulnerabilities and exploitations in their products. Nonetheless, issues persist related to the delays in the application of patches for discovered vulnerabilities [70] so that software/hardware providers must acknowledge these delays and work with users to accelerate the rate at which patches take effect. Furthermore, in practice, once the lifecycle of a piece of software/hardware has run its course, providers no longer offer automatic fixes, updates, or online technical assistance for the product. This leaves those older, yet widely used products vulnerable to attack. The WannaCry Hurricane attack in May 2017 is one recent example of such cyber incidents [63]. Thus, there is a need to discuss policies related to product support lifecycle, and the responsibility for providers and users when older versions of products are still widely used.
- *Security Companies*, put simply, must fight cyber-attacks, especially the payloads. Many technologies such as pattern matching, static analysis, dynamic analysis, hybrid analysis, and even human analysis have been presented over the years as solutions to defend against cyber-attacks [2, 27, 75, 76]. Beside these catch-up efforts, it will be beneficial to adopt the hacker mindset and work accordingly to identify ways in which security defenses could be bypassed. Inspired by bug bounty programs for vulnerability discovery, security companies could offer similar programs to hire external experts, such as cybersecurity researchers, to develop effective obfuscation techniques and render them ineffective by updating security measures before the same techniques are developed or exploited by cybercriminals. Additionally, if security companies can set up honeypot-style security checkers through SCaaS (security checker), it could be possible for the security companies to collect information to combat future cyber-attacks.
- *Infrastructure operators* such as the Internet Service Providers (ISP), according to our framework, should work to disrupt the delivery of cyber-attacks because they are in the position to monitor the Internet traffic. Though some infrastructure operators actively participated in botnet detection and abuse reporting [31, 37, 38, 61, 81], the defense side must still consider how to incentivize ISPs to involve themselves in the fight against cybercrime. It also requires international collaboration [11] to combat the cyber attack delivery, through the Internet, and the cybercriminals with which it is infested, knows no borders.
- *Financial Systems*, such as payment networks, must take responsibility for curbing the monetization activities of cybercriminals. However, in the case of the money mule recruiting service (MRaaS) to build a money laundering network, no banks or take-down companies actively pursue the elimination of money mule recruitment websites [56]. We deem it necessary to rethink financial systems' responsibilities when it comes to combatting cybercrime-

related financial transactions. In addition, the anti-money-laundering operations are ill prepared to deal with digital currencies, such as BitCoin, which inhabit a legal gray area [14]. Hence, the financial sector should emphasize collaboration, and acknowledge its shortcomings when it comes to digital currency-related cybercrime monetization activities.

- *Government* has an important role in combatting cybercrime, given its position to address market failures related to cybersecurity. Just as we mentioned above, it may be in the government's interest to develop strategies to take down or control the dark web market places directly or flood them with fake goods to destroy its reputation system for identify uncertainty mitigation. Furthermore, because the defensive and offensive sides are using largely the similar innovations, it is paramount to ensure trainees work for the right side. The government should consider strategies to recruit skilled individuals to the defensive side and combat incentives that drive them to join the cybercrime business.
- *Third-party threat intelligence service providers* should monitor dark web activity to study how cybercriminals reuse the achievements from successful attacks. More third-party services focused on TPaaS (tool pool), DMaaS (domain knowledge), PPaaS (personal profile), and TSaaS (target selection) would be welcomed in the cybersecurity community, since more information translates to greater preparedness in the face of cyber-threats. However, how to motivate them to work for the defensive side instead of the cybercriminal ecosystem is still an unclear but paramount issue.

Intuitively, only emphasizing the *individuals and corporations* to protect themselves is not an effective policy. All these actors need to take specific responsibilities and collaborate with each other to strike the cyber threat capability supply chain. Policies to motivate them to take action are urgently needed.

REFERENCES

- [1] Lillian Ablon, Martin C. Libicki, and Andrea A. Golay. 2014. *Markets for Cybercrime Tools and Stolen Data: Hackers' Bazaar*. Technical Report. RAND Corporation. 1–85.
- [2] Yasemin Acar, Michael Backes, Sven Bugiel, Sascha Fahl, Patrick Mcdaniel, and Matthew Smith. 2016. SoK: Lessons learned from Android security research for appified software platforms. In *Proceedings of the 2016 IEEE Symposium on Security and Privacy*. 433–451.
- [3] Mitsuaki Akiyama, Takeshi Yagi, Takeo Hariu, and Youki Kadobayashi. 2017. HoneyCirculator: Distributing credential honeypot for introspection of web-based attack cycle. *Int. J. Info. Secur.* 17, 2 (2017), 135–151. DOI:<http://dx.doi.org/10.1007/s10207-017-0361-5>
- [4] Luca Allodi, Marco Corradin, and Fabio Massacci. 2016. Then and now: On the maturity of the cybercrime markets the lesson that black-hat marketers learned. *IEEE Trans. Emerg. Topics Comput.* 4, 1 (2016), 35–46.
- [5] Ross Anderson. 2001. Why information security is hard-an economic perspective. In *Proceedings 17th Annual Computer Security Applications Conference*. IEEE, 358–365.
- [6] Ross Anderson and Tyler Moore. 2006. The economics of information security. *Science* 314, 5799 (2006), 610–613.
- [7] Claudio A. Ardagna, Rasool Asal, Ernesto Damiani, and Quang Hieu Vu. 2015. From security to assurance in the cloud: A survey. *Comput. Surveys* 48, 1 (2015), 2:1–2:50.
- [8] Thanassis Avgerinos, Sang Kil Cha, Brent Lim, Tze Hao, and David Brumley. 2011. AEG: Automatic exploit generation. In *Proceedings of the 18th Annual Network and Distributed System Security Symposium*, Vol. 14. 1–18.
- [9] Tiffany Bao, Ruoyu Wang, Yan Shoshitaishvili, and David Brumley. 2017. Your exploit is mine: Automatic shellcode transplant for remote exploits. In *Proceedings of the IEEE Symposium on Security and Privacy*. 824–839.
- [10] Bradley Barth. 2018. RIG and GrandSoft exploit kits shell out new GandCrab ransomware. Retrieved from www.scmagazine.com/rig-and-grandsoft-exploit-kits-shell-out-new-gandcrab-ransomware/article/740900/.
- [11] Danny Bradbury. 2014. Testing the defences of bulletproof hosting companies. *Netw. Secur.* 2014, 6 (2014), 8–12.
- [12] Roderic Broadhurst, Peter Grabosky, Mamoun Alazab, and Steve Chon. 2014. Organizations and cyber crime: An analysis of the nature of groups engaged in cyber crime. *Int. J. Cyber Criminol.* 8, 1 (2014), 1–20.
- [13] David Brumley, Pongsin Pooankam, Dawn Song, and Jiang Zheng. 2008. Automatic patch-based exploit generation is possible: Techniques and implications. In *Proceedings of the IEEE Symposium on Security and Privacy*. 143–157.
- [14] Danton Bryans. 2014. *Bitcoin and Money Laundering: Mining for an Effective Solution*. Vol. 89. 441–472.

- [15] Juan Caballero, Chris Grier, Christian Kreibich, and Vern Paxson. 2011. Measuring pay-per-install: The commoditization of malware distribution. In *Proceedings of the USENIX Security Symposium*. 13:1–13:16.
- [16] Jian Chang, Krishna K. Venkatasubramanian, Andrew G. West, and Insup Lee. 2013. Analyzing and defending against web-based malware. *Comput. Surveys* 45, 4 (2013), 1–35.
- [17] Nazli Choucri, Stuart Madnick, and Priscilla Koepke. 2016. Institutions for cyber security: International responses and data sharing initiatives. Working Paper CISL#2016-10. <https://ic3.mit.edu/wp-content/uploads/2016-11.pdf>.
- [18] Nicolas Christin. 2013. Traveling the silk road: A measurement analysis of a large anonymous online marketplace. In *Proceedings of the 22nd International Conference on World Wide Web*. 213–224.
- [19] Cuong Xuan Chu, Niket Tandon, and Gerhard Weikum. 2017. Distilling task knowledge from how-to communities. In *Proceedings of the World Wide Web Conference*. 805–814.
- [20] Cisco. 2016. *Cisco 2016 Annual Security Report*. Technical Report. 1–87.
- [21] David D. Clark. 2012. Control point analysis. In *Proceedings of the Transient Receptor Potential Canonical Conference (TRPC'12)*. 25. Retrieved from <http://papers.ssrn.com/sol3/papers.cfm?abstract>.
- [22] CSIMarket. 2017. CSIMarket Return on Investment Screening. Retrieved from <https://csimarket.com/screening/index.php?s=roi>.
- [23] DEEPDOTWEB. 2018. Updated: List of dark net markets. Retrieved from <https://www.deepdotweb.com/2013/10/28/updated-llist-of-hidden-marketplaces-tor-i2p/>.
- [24] DEEPWEBADMIN. 2017. Build a black market in dark web only for \$4500; Cybercrime goes PAAS. Retrieved from <https://www.deepweb-sites.com/build-black-market-dark-web-4500-cybercrime-goes-paas/>.
- [25] Thomas Donilon, Chair Samuel Palmisano, Keith Alexander, Ana Antón, Ajay Banga, Steven Chabinsky, Patrick Gallagher, Peter Lee, Herbert Lin, Heather Murren, Joseph Sullivan, Maggie Wilderotter, and Kiersten Todt. 2016. *Commission on Enhancing National Cybersecurity*. Technical Report. NIST, 1–100.
- [26] E-ISAC and SANS. 2016. *Analysis of the Cyber Attack on the Ukrainian Power Grid*. Technical Report.
- [27] Manuel Egele, Theodoor Scholte, Engin Kirda, and Christopher Kruegel. 2012. A survey on automated dynamic malware-analysis techniques and tools. *Comput. Surveys* 44, 2 (2012), 1–42.
- [28] Thomas Fox-Brewster. 2017. Forget Silk Road, cops just scored their biggest victory against the dark web drug trade. Retrieved from <https://www.forbes.com/sites/thomasbrewster/2017/07/20/alphabay-hansa-dark-web-markets-taken-down-in-massive-drug-bust-operation>.
- [29] Anonymous France. 2016. Anonymity and privacy first lesson taught on OnionIRC. Retrieved from <https://www.anonymous-france.eu/anonymity-and-privacy-first-lesson-taught-on-onionirc.html>.
- [30] Jerry Gao, Xiaoying Bai, Wei-Tek Tsai, and Tadahiro Uehara. 2014. Mobile application testing: A tutorial. *Computer* 47, 2 (2014), 46–55.
- [31] Max Goncharov. 2012. *Russian Underground 101*. Technical Report. Trend Micro. 1–29.
- [32] Chen Hajaj, Noam Hazon, and David Sarne. 2017. Enhancing comparison shopping agents through ordering and gradual information disclosure. *Auton. Agents Multi-Agent Syst.* 31, 3 (2017), 696–714.
- [33] Andreas Haslebacher, Jeremiah Onalapo, and Gianluca Stringhini. 2016. All your cards are belong to us: Understanding online carding forums. *CoRR abs/1607.00117* 1 (2016). <http://arxiv.org/abs/1607.00117>.
- [34] Ryan Heartfield and George Loukas. 2015. A taxonomy of attacks and a survey of defence mechanisms for semantic social engineering attacks. *Comput. Surveys* 48, 3 (2015), 1–39.
- [35] Keman Huang, Jia Zhang, Wei Tan, and Zhiyong Feng. 2017. Shifting to mobile: Network-based empirical study of mobile vulnerability market. *IEEE Trans. Services Comput.* 99 (2017), 1–14.
- [36] Inj3ct0r. 2018. Oday.today. Retrieved from <https://oday.today>.
- [37] M. O'Reirdan J. Livingood, and N. Mody. 2011. Recommendations for the remediation of bots in ISP Networks draft-oreirdan-mody-bot-remediation-16. *Internet Eng. Task Force* (2011), 1–33.
- [38] Mohammad Hanif Jhaveri, Orcun Cetin, Carlos Gañán, Tyler Moore, and Michel Van Eeten. 2017. Abuse reporting and the fight against cybercrime. *Comput. Surveys* 49, 4 (2017), 1–27.
- [39] Steven K. 2011. Tracking cyber crime: scan4you.net (private AV checker). Retrieved from <http://www.xylibox.com/2011/10/scan4younet-private-av-checker.html>.
- [40] Kafeine. 2016. Is it the end of Angler? Retrieved from <http://malware.dontneedcoffee.com/2016/06/is-it-end-of-angler.html>.
- [41] Kafeine. 2017. CoalaBot: http Ddos Bot. Retrieved from <http://malware.dontneedcoffee.com/2017/10/coalabot-http-ddos-bot.html>.
- [42] Vitaly Kamluk and Alexander Gostev. 2016. *Adwind-a Cross Platform RAT*. Technical Report February. Kaspersky.
- [43] Ahmed Kosba, Andrew Miller, Elaine Shi, Zikai Wen, and Charalampos Papamanthou. 2016. Hawk: The blockchain model of cryptography and privacy-preserving smart contracts. In *Proceedings of the 2016 IEEE Symposium on Security and Privacy*. 839–858. DOI: <http://dx.doi.org/10.1109/SP.2016.55>

- [44] Aron Laszka, Mark Felegyhazi, and Levente Buttyan. 2014. A survey of interdependent information security games. *ACM Comput. Surveys* 47, 2 (2014), 1–38.
- [45] Stefan Laube and Rainer Böhme. 2017. Strategic aspects of cyber risk information sharing. *Comput. Surveys* (2017).
- [46] E. R. Leukfeldt. 2014. Cybercrime and social ties: Phishing in amsterdam. *Trends Organized Crime* 17, 4 (2014), 231–249.
- [47] Robert Luh, Stefan Marschalek, Manfred Kaiser, Helge Janicke, and Sebastian Schrittwieser. 2017. Semantics-aware detection of targeted attacks: A survey. *J. Comput. Virol. Hacking Techn.* 13, 1 (2017), 47–85.
- [48] Stuart Madnick. 2016. Dark Web: Hackers trump good guys in sharing information. <https://searchcio.techtarget.com/news/450295259/Stuart-Madnick-Dark-Web-hackers-trump-good-guys-in-sharing-information>.
- [49] Derek Manky. 2013. Cybercrime as a service: A very modern business. *Comput. Fraud Secur.* 6 (2013), 9–13.
- [50] Steve Mansfield-Devine. 2016. The imitation game: How business email compromise scams are robbing organisations. *Comput. Fraud Secur.* 11 (2016), 5–10.
- [51] Etay Maor. 2013. No money mule, no problem: Recruitment website kits for sale. Retrieved from <https://securityintelligence.com/money-mule-problem-recruitment-website-kits-sale/>.
- [52] Max Goncharov. 2015. *Criminal Hideouts for Lease: Bulletproof Hosting Services*. Technical Report. Trend Micro.
- [53] McAfee Inc. 2016. *McAfee Labs 2017 Threats Predictions*. Technical Report, November. 1–51.
- [54] McKinsey & Company. 2015. *A Labor Market That Works: Connecting Talent With Opportunity in the Digital Age*. Technical Report, June.
- [55] Tyler Moore. 2010. Introducing the economics of cybersecurity: Principles and policy options. In *Proceedings of the Workshop on Deterring Cyberattacks: Informing Strategies and DEveloping Options for U.S. Policy*. 3–23.
- [56] Tyler Moore and Richard Clayton. 2009. The impact of incentives on notice and take-down. In *Managing Information Risk and the Economics of Security*. Springer, Boston, 199–223. <http://dx.doi.org/10.1007/978-0-387-09762-6>.
- [57] Marcin Nawrocki, Matthias Wählisch, Thomas C. Schmidt, Christian Keil, and Jochen Schönfelder. 2016. A survey on honeypot software and data analysis. *Eprint arXiv:1608.06249* (2016), 1–38.
- [58] Arash Nourian and Stuart Madnick. 2015. A systems theoretic approach to the security threats in cyber physical systems applied to stuxnet. *IEEE Trans. Depend. Secure Comput.* 99 (2015), 20.
- [59] Jeremiah Onalapo, Enrico Mariconti, and Gianluca Stringhini. 2016. What happens after you are pwned: Understanding the use of leaked account credentials in the wild. In *Proceedings of the ACM SIGCOMM Conference on Internet Measurement Conference*. 1–15.
- [60] Pierluigi Paganini. 2016. Ran\$umBin a dark web service dedicated to ransomware. Retrieved from <http://securityaffairs.co/wordpress/46770/breaking-news/46770.html>.
- [61] Jeroen Pijpker and Harald Vranken. 2016. The role of internet service providers in botnet mitigation. In *Proceedings of the 2016 European Intelligence and Security Informatics Conference*. 24–31. DOI : <http://dx.doi.org/10.1109/EISIC.2016.013>
- [62] Peter Reuter and Edwin M. Truman. 2003. Money laundering: Methods and markets. In *Chasing Dirty Money: The Fight Against Money Laundering*. Peterson Institute, 25–43. DOI : <http://dx.doi.org/10.1108/13685200310809699>
- [63] Charles H. Romine. 2017. Bolstering government cybersecurity lessons learned from WannaCry. Retrieved from <https://www.nist.gov/speech-testimony/bolstering-government-cybersecurity-lessons-learned-wannacry>.
- [64] Ryan Ellis, Keman Huang, Michael Siegel, Katie Moussouris, and James Houghton. 2017. Fixing a hole: The labor market for bugs. In *New Solutions for Cybersecurity*, Alex Pentland, Howard Shrobe, and David Shrier (Eds.). MIT Press, 122–147.
- [65] Hamid Salim and Stuart Madnick. 2016. Cyber safety: A systems theory approach to managing cyber security risks-applied to TJX cyber attack. Cybersecurity at MIT Sloan, Working Paper, 1–17. <http://web.mit.edu/smadnick/www/wp/2016-09.pdf>.
- [66] Hamid M. Salim. 2014. *Cyber Safety : A Systems Thinking and Systems Theory Approach to Managing Cyber Security Risks*. Ph.D. Dissertation. Massachusetts Institute of Technology.
- [67] Raj Samani and Francois Paget. 2013. *Cybercrime Exposed: Cybercrime-as-a-Service*. Technical Report. McAfee. 1–18.
- [68] Sebastian Schrittwieser, Johannes Kinder, Georg Merzdovnik, Edgar Weippl, and Stefan Katzenbeisser. 2015. Protecting software through obfuscation: Can it keep pace with progress in code analysis? *Comput. Surveys* 49, 4 (2015), 1–40.
- [69] Offensive Security. 2017. Offensive security training, certifications and services. Retrieved from <https://www.offensive-security.com/>.
- [70] Muhammad Shahzad, Muhammad Zubair Shafiq, and Alex X Liu. 2012. A large scale exploratory analysis of software vulnerability life cycles. In *Proceedings of the 34th International Conference on Software Engineering*. 771–781.
- [71] Yan Shoshitaishvili, Ruoyu Wang, Christopher Salls, Nick Stephens, Mario Polino, Andrew Dutcher, John Grosen, Siji Feng, Christophe Hauser, Christopher Kruegel, and Giovanni Vigna. 2016. SOK: (State of) the art of war: Offensive techniques in binary analysis. In *Proceedings of the IEEE Symposium on Security and Privacy*. 138–157.

- [72] Aditya K. Sood and Richard J. Enbody. 2013. Crimeware-as-a-service-a survey of commoditized crimeware in the underground market. *Int. J. Crit. Infrastruct. Protect.* 6, 1 (2013), 28–38.
- [73] Aditya K. Sood and Richard J. Enbody. 2013. Targeted cyberattacks: A superset of advanced persistent threats. *IEEE Secur. Privacy* 11, 1 (2013), 54–61.
- [74] Steemit. 2017. theshadowbrokers. Retrieved from <https://steemit.com/@theshadowbrokers>.
- [75] Sufatrio, Darell J. J. Tan, Tong-wei Chua, and Vrizlynn L. L. Thing. 2015. Securing android: A survey, taxonomy, and challenges. *Comput. Surveys* 47, 4 (2015), 1–45.
- [76] Kimberly Tam, A. L. I. Feizollah, N. O. R. Badrul Anuar, Rosli Salleh, and Lorenzo Cavallaro. 2017. The evolution of android malware and android analysis techniques. *Comput. Surveys* 49, 4 (2017), 1–41.
- [77] Digital Shadows Analyst Team. 2017. Innovation in the underworld: Reducing the risk of ripper fraud. Retrieved from <https://www.digitalsadows.com/blog-and-research/innovation-in-the-underworld-reducing-the-risk-of-ripper-fraud>.
- [78] Kurt Thomas, Juan Antonio Elices Crespo, Ryan Rasti, Jean-Michel Picod, Damon Mccoy, Lucas Ballard, Elie Bursztein, Moheeb Abu Rajab, and Niels Provos. 2016. Investigating commercial pay-per-install and the distribution of unwanted software. In *Proceedings of the 25th USENIX Security Symposium*. 721–738.
- [79] Kurt Thomas, Danny Huang, David Wang, Elie Bursztein, Chris Grier, Thomas J. Holt, Christopher Kruegel, Damon McCoy, Stefan Savage, and Giovanni Vigna. 2015. Framing dependencies introduced by underground commoditization. In *Proceedings of the Workshop on the Economics of Information Security*. 1–24.
- [80] TorHiddenwiki. 2017. Hire a hacker on the deep web. Retrieved from <https://torhiddenwiki.com/2017/04/03/hire-a-hacker-on-the-deep-web/>.
- [81] Michel van Eeten, Johannes M. Bauer, Hadi Asghari, and Shirin Tabatabaie. 2010. The role of internet service providers in botnet mitigation: An empirical analysis based on spam data. OECD Science, Technology and Industry Working Papers, No. 2010/05, OECD Publishing, Paris. <http://dx.doi.org/10.1787/5km4k7m9n3vj-en>.
- [82] Timothy Vidas and Nicolas Christin. 2013. Sweetening android lemon markets: Measuring and combating malware in application marketplaces. In *Proceedings of the 3rd ACM Conference on Data and Application Security and Privacy*, vol. 2011. 197–207.
- [83] John Wadleigh, Jake Drew, and Tyler Moore. 2015. The e-commerce market for “lemons”: Identification and analysis of websites selling counterfeit goods. In *The Proceedings of the 24th International Conference on World Wide Web*. 1188–1197.
- [84] Cale Guthrie Weissman. 2015. Nine things you can hire a hacker to do and how much it will (generally) cost. Retrieved from <http://www.businessinsider.com/9-things-you-can-hire-a-hacker-to-do-and-how-much-it-will-generally-cost-2015-5?op=1>.
- [85] Trenton A. Williams, Daniel A. Gruber, Kathleen M. Sutcliffe, Dean A. Shepherd, and Eric Yanfei Zhao. 2017. Organizational response to adversity: Fusing crisis management and resilience research streams. *Acad. Manage. Ann.* 11, 2 (2017), 733–769.
- [86] Eric Wustrow and Benjamin VanderSloot. 2016. DDoSCoin: Cryptocurrency with a malicious proof-of-work. In *Proceedings of the USENIX Workshop on Offensive Technologies*.
- [87] Haitao Xu, Daiping Liu, Haining Wang, and Angelos Stavrou. 2015. E-commerce reputation manipulation: The emergence of reputation-escalation-as-a-service. In *Proceedings of the 24th International Conference on World Wide Web*. 1296–1306.
- [88] Ziming Zhao, Mukund Sankaran, Gail Joon Ahn, Thomas J. Holt, Yiming Jing, and Hongxin Hu. 2016. Mules, seals, and attacking tools: Analyzing 12 online marketplaces. *IEEE Secur. Privacy* 14, 3 (2016), 32–43.

Received November 2017; revised March 2018; accepted March 2018