

**Strategic Development of a Manufacturing Execution System (MES)
for Cold Chain Management using Information Product Mapping**

Todd Andrew Waldron

Working Paper CISL# 2010-07

June 2010

Composite Information Systems Laboratory (CISL)
Sloan School of Management, Room E53-320
Massachusetts Institute of Technology
Cambridge, MA 02142

Strategic Development of a Manufacturing Execution System (MES) for Cold Chain Management using Information Product Mapping

by

Todd Andrew Waldron

B.S. Chemical Engineering, Drexel University, 2002

M. Biotechnology, University of Pennsylvania, 2007

Submitted to the MIT Sloan School of Management and the Engineering Systems Division in Partial Fulfillment of the Requirements for the Degrees of

**Master of Business Administration
AND
Master of Science in Chemical Engineering**

In conjunction with the Leaders for Global Operations Program at the

**Massachusetts Institute of Technology
June 2011**

© 2011 Massachusetts Institute of Technology. All rights reserved.

Signature of Author _____
May 6, 2011
Chemical Engineering, MIT Sloan School of Management

Certified by _____
Stuart Madnick, Thesis Supervisor
John Norris Maguire Professor of Information Technology, MIT Sloan School of Management

Certified by _____
J. Christopher Love, Thesis Supervisor
Texaco-Mangelsdorf Career Development Professor of Chemical Engineering

Accepted by _____
William Deen, Chairman, Committee for Graduate Students
Department of Chemical Engineering

Accepted by _____
Debbie Berechman, Executive Director of MBA Program
MIT Sloan School of Management

This page intentionally left blank.

Strategic Development of a Manufacturing Execution System (MES) for Cold Chain Management using Information Product Mapping

by

Todd Andrew Waldron

Submitted to the MIT Sloan School of Management and the Department of Chemical Engineering
in Partial Fulfillment of the Requirements for the Degrees of

**Master of Business Administration
AND
Master of Science in Chemical Engineering**

ABSTRACT

The Vaccines & Diagnostics (V&D) division of Novartis recently developed a global automation strategy that highlights the need to implement manufacturing execution systems (MES). Benefits of MES (electronic production records) include enhancing the compliance position of the organization, reducing production delays, and improving process flexibility, however implementing MES at global manufacturing sites presents unique logistical challenges that need to be overcome.

The goal of this thesis is to investigate cold chain management as an expanded functionality for MES. The thesis attempts to identify best practices for the strategic implementation of MES in the management of cold chain vaccine products. While the concepts shared in this thesis are in the context of managing the cold chain for vaccine product, the best practices can be applied to a variety of cold chain management scenarios.

In order to generate best practice recommendations for the strategic implementation of a cold chain management MES, a thorough understanding of the manufacturing process will need to be acquired. The first tool used to gain this understanding was Value Stream Mapping (VSM). VSM provided some insight into the current paper-based cold chain management system, however, the tool was not applicable for understanding the flow of information generated within the cold chain management system.

Another tool was used to enable the organization to focus on the data generated by a process, the Information Product Map (IP-Map). Current-state IP-Maps of the Rosia, Italy, site cold chain were generated and numerous areas for improving the data quality were identified. Future-state IP-Maps of the Rosia, Italy, site cold chain were generated to demonstrate how the implementation of a cold chain MES could improve the shortcomings of the current system.

The future-state IP maps were based on two major underlying assumptions that directly lead to recommendations for the cold chain MES implementation. The first recommendation is that a unit of measurement smaller than lot size must be selected for tracking material data in the MES. The second recommendation is that data capture technology for material entering or leaving cold storage must be integrated with the MES.

Thesis Supervisor: Stuart Madnick
John Norris Maguire Professor of Information Technology, MIT Sloan School of Management

Thesis Supervisor: J. Christopher Love
Texaco-Mangelsdorf Career Development Professor of Chemical Engineering

This page intentionally left blank.

ACKNOWLEDGMENTS

Acknowledgments go here.

This page intentionally left blank.

TABLE OF CONTENTS

ABSTRACT	3
ACKNOWLEDGMENTS	5
TABLE OF CONTENTS	7
TABLE OF FIGURES	9
CHAPTER 1: INTRODUCTION AND THESIS OVERVIEW	10
1.1 Problem Description.....	10
1.2 Manufacturing Execution Systems.....	10
1.3 Project Drivers.....	12
1.3.1 Enhance Compliance Position	12
1.3.2 Reduce Production Delays.....	13
1.3.3 Improve Process Flexibility.....	13
1.4 Hypothesis.....	14
1.5 Organization of Thesis	14
1.6 Confidentiality	15
CHAPTER 2: PROJECT CONTEXT	16
2.1 Company and Division Description	16
2.2 Manufacturing Cold Chain	16
2.2.1 Stability.....	16
2.2.2 Shelf-Life and Expiry.....	17
2.2.3 Time Out-of-Refrigeration	18
2.2.4 Cold Chain Management.....	18
2.3 Project Scope.....	20
CHAPTER 3: VALUE STREAM MAPPING (VSM)	21
3.1 VSM Description	21
3.2 Findings from VSM	22
3.3 VSM Shortcomings for Understanding the Cold Chain	27
CHAPTER 4: CURRENT-STATE INFORMATION PRODUCT MAPS (IP-MAPS)	29
4.1 IP-MAP Advantages for Understanding the Cold Chain	29
4.2 IP-Map Description.....	29
4.3 IP-Map Development Approach.....	31
4.4 Current-State IP-Maps.....	32
4.4.1 Transfer of Bulk Material from the Global Warehouse to the Filling and Inspection Local Cold Room.....	32
4.4.2 Filling and Inspection Processes.....	33
4.4.3 Transfer of Filled/Inspected Product from the Filling and Inspection Local Cold Room to the Packaging and Labeling Local Cold Room	36

4.4.4	<i>Packaging and Labeling Processes</i>	37
4.4.5	<i>Transfer of Finished Product from the Packaging and Labeling Local Cold Room to the Global Warehouse</i>	41
4.4.6	<i>Finished Product Time Out-of-Refrigeration Data Review</i>	42
4.5	Cold Chain Management Concerns Identified by the IP-Maps	43
CHAPTER 5: FUTURE-STATE INFORMATION PRODUCT MAPS (IP-MAPS)		46
5.1	Future-State IP-Maps	46
5.1.1	<i>Transfer of Bulk Material from the Global Warehouse to the Filling and Inspection Local Cold Room</i>	46
5.1.2	<i>Filling and Inspection Processes</i>	47
5.1.3	<i>Transfer of Filled/Inspected Product from the Filling and Inspection Local Cold Room to the Packaging and Labeling Local Cold Room</i>	50
5.1.4	<i>Packaging and Labeling Processes</i>	51
5.1.5	<i>Transfer of Finished Product from the Packaging and Labeling Local Cold Room to the Global Warehouse</i>	54
5.1.6	<i>Finished Product Time Out-of-Refrigeration Data Review</i>	55
5.2	Cold Chain Management Improvements Found in the Future State IP-Maps	57
CHAPTER 6: RECOMMENDATIONS		59
6.1	Select a Smaller Unit of Measurement for the Cold Chain MES	59
6.2	Ensure Cold Chain Data is Captured Automatically	62
BIBLIOGRAPHY		64

TABLE OF FIGURES

Figure 1: Manufacturing Operations Model	11
Figure 2: Vaccine Product Flow through Processing.....	23
Figure 3: Process Interruption Disrupts Material Flow.....	24
Figure 4: Division of Material during Processing.....	25
Figure 5: Processing of Material at Numerous Facilities.....	26
Figure 6: Straight Through Processing of Material.....	27
Figure 7: Information Product Map Symbol Guide	30
Figure 8: IP-Map for the Transfer of Bulk Material from the Global Warehouse	32
Figure 9: IP-Map for the Filling and Inspection Processes.....	34
Figure 10: IP-Map for the Transfer of Filled/Inspected Product from the Filling and Inspection Local Cold Room to the Packaging and Labeling Local Cold Room.....	36
Figure 11: IP-Map for the Packaging and Labeling Processes	38
Figure 12: IP-Map for the Transfer of Finished Product from the Packaging and Labeling Local Cold Room to the Global Warehouse	41
Figure 13: IP-Map for the Finished Product Time Out-of-Refrigeration Data Review	43
Figure 14: Future-State IP-Map for the Transfer of Bulk Material from the Global Warehouse to the Filling and Inspection Local Cold Room.....	47
Figure 15: Future-State IP-Map for the Filling and Inspection Processes	48
Figure 16: Future-State IP-Map for the Transfer of Filled/Inspected Product from the Filling and Inspection Local Cold Room to the Packaging and Labeling Local Cold Room	50
Figure 17: Future-State IP-Map for the Packaging and Labeling Processes.....	52
Figure 18: Future-State IP-Map for the Transfer of Finished Product from the Packaging and Labeling Local Cold Room to the Global Warehouse	55
Figure 19: Future-State IP-Map for the Finished Product Time Out-of-Refrigeration Data Review	56

CHAPTER 1: INTRODUCTION AND THESIS OVERVIEW

1.1 Problem Description

Novartis Vaccines & Diagnostics (V&D) division is currently characterized by a series of manual activities for capturing and reviewing process information. Manual data capture and review leads to a low level of transparency, investigational capability, and process integration. In light of these deficiencies, the V&D division recently developed a new global automation strategy that highlights the importance of Manufacturing Execution Systems (MES). MES have been identified as the main tool in the business transformation road map that defines, documents, and controls all relevant production and quality parameters. Strategically implemented MES have the capability to generate a competitive advantage for the division through high levels of data transparency and flexible process integration.

Vaccine products must be maintained within a cold chain throughout their lifecycle in the manufacturing facility. Maintaining vaccine products at proper refrigerated storage conditions in between processing steps is a critical component to ensuring the effectiveness of the product. Calculating the time out-of-refrigeration for vaccine product is a manually intensive process performed across a number of functional groups within the V&D division. Manual data capture leads to an increased cycle time and inefficient use of resources. MES are a tool that can automatically collect and analyze time out-of-refrigeration data for vaccine product throughout the division, empowering key stakeholders to make data-driven processing decisions.

This thesis is based on work that was performed by the author over a six and a half month period at the Rosia, Italy, site of Novartis V&D. The goal of this thesis is to investigate cold chain management as an expanded functionality for MES. The thesis attempts to identify what the best practices are for strategic implementation of MES in the management of cold chain vaccine products. While the concepts shared in this thesis are in the context of managing the cold chain for vaccine product, the best practices can be applied to a variety of cold chain management scenarios.

1.2 Manufacturing Execution Systems

The manufacturing operations model of the pharmaceutical industry can be described as overlaying levels of management. Lower levels manage local events that have a discrete impact while higher levels direct global changes that have widespread implications. Information technology systems

can be used to manage a layer of the model or to enhance communications between the layers of the model.

Level 0, the plant level, represents the actual production process. Level 1, the instrumentation level, represents the equipment that sense and manipulate the production process. Instruments in Level 1 take measurements of the Level 0 production. Level 2, the control level, represents the automation that controls the production process. Process control systems (PCS) that direct infrastructure based on readings from Level 1 instruments are also called supervisory control and data acquisition (SCADA) systems. Information collected from the Level 1 instruments are often stored in data historians at Level 2. Level 3, the operations level, represents the production recipes and work flows that produce the desired products. MES manage the manufacturing steps that are controlled by Level 2 automation. PCS control all relevant process parameters whose validated ranges are defined by the MES. Level 4, the business planning level, manages the overall production plan and material flow. Enterprise resource planning (ERP) software collects data from accounting, sales, and planning to determine the work orders to meet demand forecasts. MES schedule production process in an optimal way based on instructions from the Level 4 production plans (Allan, 2009).

Figure 1: Manufacturing Operations Model

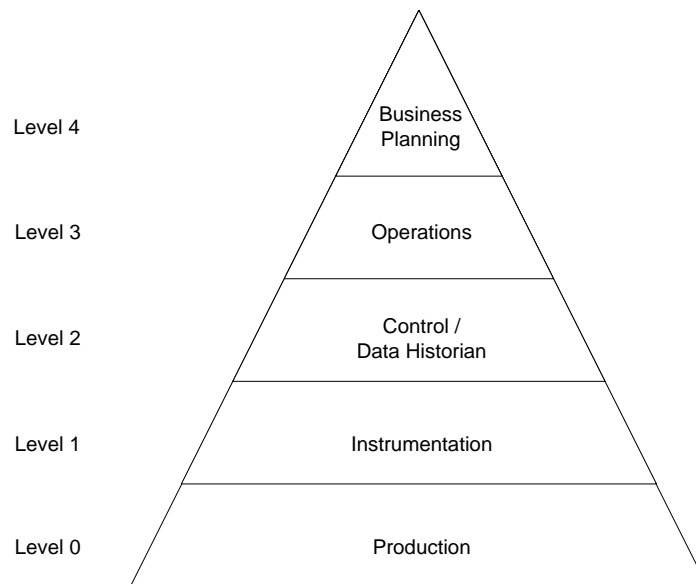

MES are the electronic interface that links the personnel, instruments, equipment, and automation of the shop floor with the inventory, planning, logistics, and finance of management. MES build this bridge by being the electronic interface that directs production and quality control systems (Blumenthal, 2004). The most important feature of MES is their management of electronic batch records. Production

batch records serve as the instructions for supervisors and process technicians. Production batch records contain all of the critical information about processing steps. Information about who executed the steps and when the steps were executed are recorded in the production batch record. Production batch records can also include ranges for critical process parameters. Examples of critical process parameters include the weight of material additions, the temperature of process tanks, and the pH of process fluids. Critical process parameter data from instruments can be recorded in the process batch records and compared against pre-defined ranges. Electronic batch records automatically associate captured process data with the appropriate batch record.

1.3 Project Drivers

Strategic implementation of MES to bridge the Operations and Control levels of the manufacturing operations hierarchy has regulatory and financial benefits. The business impact of this implementation includes an enhanced compliance position for the division, reductions in production delays, and improved process flexibility for enhanced use of organization resources.

1.3.1 Enhance Compliance Position

The first main benefit of MES implementation is their ability to enhance the compliance position of the organization. Maintaining positive relationships with worldwide regulatory agencies is important when trying to resolve manufacturing issues that fall under their jurisdiction and when trying to promote new technologies and products for your company portfolio. Processing data that is recorded from instruments into documents by a technician has the opportunity to be compromised. In order to prevent the unintentional inclusion of incorrect data to a batch record, a check of the data entry by another technician or supervisor is often incorporated into data capture procedures. Manual data capture removes technicians and supervisors from critical processing functions that ensure the batch is being manufactured according to the approved procedures. MES can automatically verify information captured by instruments and associate that data with the correct electronic batch record. The MES can also be programmed to collect process data at specific time points during the process so the division is not dependent on manual data entry, which could be impacted by the availability of labor.

In addition to associating data with a specific batch record, the functionality of the MES can be used to compare the data to an expected result. If the process data is outside of a predefined range, the MES can flag the result internally or in conjunction with another system and send a notification to begin an investigation into the result. The data that is managed by the MES can be archived in a data historian. The functionality of the MES can interact with the data historian to aid investigations and process

improvement projects. When paper-based batch records are in place, data mining for investigations is a time-consuming process. Questions that require data about previous lots of material require the investigator to go back to the source documents and have his data audited. MES systems that interface with a data historian allow data that has already been reviewed to be easily accessed and organized by the investigator. Additionally, this data can be used to map process trends, increasing visibility and allowing supervisors and technicians to take preventative actions.

1.3.2 Reduce Production Delays

The next main benefit of MES implementation is their ability to reduce production delays. Having verified data automatically associated with electronic batch records not only enhances the compliance position of the organization, but it can also decrease product release cycle time. Since all batch data is available as soon as manufacturing is complete, personnel in the quality and release departments have immediate access to batch information. Quality personnel are no longer responsible for a line-by-line review of the paper batch records to ensure all of the data is accurate and has been verified. The MES electronic batch record allows quality personnel to focus on critical process parameters, completing their batch record review to release the associated material to the market in a fraction of the time compared to the paper-based system. Expedited review of the batch record can help material get to the market quicker, allowing the division to capitalize on a new market or preventing a possible stock-out situation for a health care critical product.

1.3.3 Improve Process Flexibility

The last main benefit of MES implementation is their ability to improve the process flexibility of the organization. Processing material is comprised of similar steps such as measuring raw material, adding vaccine fluids to a tank for formulation, or packaging a vial. Each of these steps is comprised of almost identical instructions. The basic instructions can be programmed into MES and linked together to form basic operation blocks. MES store these basic operations blocks and allows the user to create electronic batch records from these building blocks. The batch records designer saves a great deal of time and effort because they do not have to develop a batch record from basic instructions each time a new product is added to the manufacturing site. Additionally, the operations blocks of the batch record can be universally modified if improvements to a manufacturing process are implemented.

Having a standard interface for electronic batch records across the division improves production intelligence across the organization. Resources can be shared across processes or across sites without additional training on how to work with the batch record. Before MES, operations personnel that are

assigned responsibilities in another department needed to learn the how the paper batch records were organized locally and how data was collected and entered into the batch record before they could begin training on the local processing steps. Now that the interface is the same for all batch records, the operator only needs to be trained on the process steps before they can deliver value-added work to the area. MES allow for greater flexibility in assigning the work force which makes the division more adept at handling unexpected product demand spikes.

1.4 Hypothesis

MES are an established information technology tool for improving data transparency, investigational capability, and process integration. MES have the capability to manage products maintained within a cold chain if they are implemented appropriately. Best practices for strategic implantation of cold chain management MES can be developed with the aid of process mapping techniques.

1.5 Organization of Thesis

Chapter 1 explains the problem and project motivation, defines manufacturing execution systems, and states the hypothesis.

Chapter 2 describes the company, division background, and project scope and defines cold chain management.

Chapter 3 defines value stream mapping, explains the benefits derived from initial use of this tool, and discusses the limitations of the tool when analyzing cold chain management information flow.

Chapter 4 discusses why information product mapping is a valuable tool for analyzing cold chain management information flow, defines information product mapping, and reviews maps for the current-state cold chain management processes.

Chapter 5 discusses the benefits of manufacturing execution systems for cold chain management and reviews maps of the future-state cold chain managed by manufacturing execution systems.

Chapter 6 provides best practice recommendations for the cold chain management implementation.

1.6 Confidentiality

Production data and diagrams presented in this thesis have been distorted or are hypothetical for the purpose of ensuring the confidentiality of information proprietary to Novartis.

CHAPTER 2: PROJECT CONTEXT

2.1 Company and Division Description

Novartis International AG is a multinational pharmaceutical company headquartered in Basel, Switzerland. Novartis was formed in 1996 by the merger of Ciba-Geigy and Sandoz Laboratories. The company is divided into four international divisions: pharmaceuticals, vaccines and diagnostics, Sandoz (generic pharmaceuticals), and consumer health. The V&D division was added to the company in 2006 after the acquisition of Chiron Corporation.

The history of mergers and acquisitions that characterized the formation of Novartis has also shaped the current culture of the company. The divisions of the company act independently and information is not readily exchanged across divisional boundaries. Each division develops its own strategies and creates its own vision for future success. Communicating best practices across divisions is an important source of time and cost savings for Novartis. The V&D division is segmented in the same manner as the parent company based on the acquisition of the Chiron Corporation. Creating one vision for the division and finding common platforms to promote operational efficiencies are a key part of the division strategy.

In 2010, Novartis had more than \$50.6 billion in net sales. The V&D division accounted for \$2.9 billion in sales, or 6 percent of total net sales. V&D is the smallest of the four divisions by revenue, however, the division had a 25% increase in constant currency net sales from their total in 2009. The division also has a strong pipeline that includes 15 vaccine candidates currently in clinical trials (Novartis, 2010). The V&D division seeks to demonstrate that they are a critical piece of the Novartis portfolio. The division has committed to have systems in place to support its strategic growth. This project will strive to develop best practices for a cold chain management MES that will increase flexibility among the operations sites and prepare the division to readily accept new products and handle increased demand.

2.2 Manufacturing Cold Chain

2.2.1 Stability

Legislative assemblies in countries around the world have mandated regulatory agencies to control the approval of vaccines before they can be marketed to the public. Major regulatory agencies include the Center for Biologics Evaluation and Research (CBER), a branch of the United States Food

and Drug Administration (FDA), the European Medicines Agency (EMA) and the Pharmaceuticals and Medical Devices Agency (PMDA) in Japan. Each regulatory body has specific guidelines for determining the safety, purity, and efficacy of vaccines before they can be licensed for sale to the public. Worldwide regulatory authorities also require each lot of vaccine to be tested for critical properties including safety, efficacy, identity, potency, and stability before giving their approval for release to market.

Stability is a measure of the ability of a vaccine to retain its physical, chemical, and biological properties. Stability testing of a vaccine product usually refers to the thermostability of that product, or the stability of the vaccine at various temperatures. Thermostability is determined by measuring the change in potency of a vaccine stored at a given temperature for a given period of time. Potency is the capacity of the vaccine to generate desired effects in a test, usually cell-culture or animal based, which is correlated with the immune response generated in a patient. Potency tests are important for determining the overall effectiveness of a drug. Stability studies conducted at different temperatures for different lengths of time create a thermostability profile for the vaccine that is used to generate guidelines for proper storage conditions. Long-term stability test programs are designed to evaluate storage at constant temperature, while accelerated studies evaluate the effect of short-term excursions.

The International Conference on Harmonization of Technical Requirements for Registration of Pharmaceuticals for Human Use (ICH) brings together the regulatory authorities of Europe, Japan, and the United States to discuss scientific and technical aspects of product registration (ICH, 2010). In November of 2003, the ICH released guidance for the pharmaceutical industry entitled *Q1A(R2) Stability Testing of New Drug Substances and Products* (ICH, 2003). The guidance provides vaccine manufacturers with recommendations on the type and amount of stability data that should be generated as part of the application package of a new drug substance.

Key recommendations from the ICH include: performing stability studies on at least three batches of drug substance that simulate the final process that will be used for production batches; ensuring the drug product is packaged in the same closure system that will be used for storage and distribution during the studies; and testing batches at a minimum frequency of every three months for the first year, every six months for the second year, and annually thereafter. Recommended storage condition temperature ranges are also provided for long-term and accelerated stability test programs (ICH, 2003).

2.2.2 Shelf-Life and Expiry

The main goals of stability studies are to determine the shelf-life for the vaccine product and the time out-of-refrigeration for the vaccine and its intermediates during manufacturing. The shelf-life of a

vaccine is the period of time in which the vaccine will be efficacious if stored at proper conditions. Vaccine shelf-life is determined by calculating the vaccine release model, which incorporates the thermostability profile at all temperatures the vaccine is exposed to and the minimum potency that is required to generate the desired immunological response in the patient. The shelf-life is then used to assign an expiry date to a specific vaccine lot, dependent on the date of manufacture of the product. The expiry date is the final day a lot of correctly stored vaccine is expected to maintain the minimum potency required to generate the necessary immune response in the patient.

2.2.3 Time Out-of-Refrigeration

Time out-of-refrigeration (TOR) is the total amount of time that a vaccine product or intermediate is outside of its specified temperature range, usually 2-8°C. Deviations from the specified temperature range can occur during processing, packaging, and shipping. Stability studies similar to those recommended by the ICH are performed on vaccine products and intermediates to determine the acceptable TOR during manufacture and shipping. The results of these stability studies provide information on how long the vaccine can be held at its recommended storage temperature and, if deviations outside of this recommended storage temperature occur, how long these TOR excursions can be to still maintain acceptable chemical and biological properties. Data from these TOR studies is also incorporated into the vaccine release model to determine product shelf-life. Therefore, monitoring and documenting TOR for each vaccine lot is an important part of managing the manufacturing cold chain for a product.

2.2.4 Cold Chain Management

Cold chain management refers to all of the policies and personnel that are used to ensure the integrity of vaccine material during manufacturing and distribution. The word “cold” refers to environmentally sensitive material and understanding the impact of removing that material from a temperature controlled environment. The word “chain” refers to the chain of custody for the material. Each time vaccine material is removed from its temperature controlled environment for processing, transportation, or storage, that information must be documented. Delivery and receipt of temperature sensitive vaccine material must be linked by the cold chain management documentation. According to the World Health Organization, in order to maintain the original quality, every activity in the distribution of pharmaceutical products should be carried out according to the principals of Good Manufacturing Practice (GMP), Good Storage Practice (GSP) and Good Distribution Practice (GDP) (World Health Organization, 2005).

Critical parameters that are measured as part of ensuring the reliability of a cold chain are developed during stability studies, shelf-life determination, and time out-of-refrigeration calculations. The thermostability profile of products maintained in the cold chain is determined during stability studies. The critical process parameter of the cold chain management system is time out-of-refrigeration. Once thermostability profiles are completed, time out-of-refrigeration limits for each of the vaccine products monitored by the cold chain management system can be determined. Responsibility for cold chain management ultimately resides with the manufacturer and regulatory agencies are requiring heightened levels of monitoring and control.

Global regulatory agencies have increased oversight to ensure the integrity of pharmaceutical products in the distribution chain. Regulatory guidance to industry, presentations by industry thought-leaders, and regulatory enforcement citations have highlights a number of trends impacting cold chain management. The first of these trends reinforces that the responsibility of managing the cold chain lies with the product manufacturer. The next trend is that cold chain management must be completed over the entire supply chain to ensure patient safety. The final trend highlights the increased importance of temperature control and monitoring to mitigate risks during product transport (Bishara, 2006). This transport can be on a global level between the manufacturer and the customer or on a local level between a product line and a warehouse. These trends will be acknowledged as part of the best practice recommendations for implementation of cold chain management MES.

Failure to comply with the increasing scrutiny on cold chain management can lead to citations from regulatory agencies. If these citations are not addressed, as deemed appropriate by the citing regulatory agency, the agency has the capacity to prevent material from being sent to the market and/or to levy substantial monetary fines. This action not only has immediate financial implications, but it can impact the reputation of the company and can draw additional scrutiny from other regulatory agencies, the media, and the public. Examples of citations handed down from the FDA include one in May of 1999 for a standard operating procedure lacking acceptance criteria for the storage and movement of material between two sites and another in October of 2001 for bulk material intended for refrigerated storage being left at ambient conditions for several days before shipping (Bishara, 2006). Strategic implantation of MES to manage the cold chain can ensure appropriate time-out-of-refrigeration procedures have been generated and associated data is gathered and analyzed.

2.3 Project Scope

Understanding that the V&D division wants to standardize information technology systems to help foster growth, having the MES manage the entire production cold chain would provide the most benefit to the division. However, establishing sensible boundaries for the work completed during internship was a necessary part of focusing the project and preparing it for success. Management of the entire V&D cold chain would include numerous production sites, all materials used in manufacturing, and governance across all production steps.

The current Novartis vaccine manufacturing network is comprised of production sites in Europe and the United States. The internship was based out of the Rosia, Italy, and therefore the cold chain management work was focused on vaccine materials throughout this site. Process experts at each of the manufacturing sites were consulted throughout the internship to ensure the best practice recommendations for MES implementation were applicable throughout the V&D network.

Production steps that occur at the Rosia, Italy, site include weigh and dispense of raw materials, bulk manufacture, formulation and filling, inspection, labeling, and packaging. Numerous vaccine products are manufactured and prepared for distribution at this site. In addition, bulk materials from sites throughout the V&D network arrive at the Rosia site for formulation, filling, and shipping. Time out-of-refrigeration data for bulk material from these sites and from bulk material that is produced in Rosia is managed by systems and procedures not associated with formulation, inspection, labeling, and packaging. For this reason, the scope of the project was focused on the processing steps from formulation to packaging.

Products that need to be maintained at controlled temperatures include raw materials from suppliers, intermediates in the manufacturing process, and finished product. Procedures with well-defined time out-of-refrigeration limits are available for the processing steps from formulation to packaging. Because the focus on the project has been narrowed to these processing steps at the Rosia site, the vaccine materials from which TOR data will be collected is constrained. Collected TOR data will be evaluated from the time vaccine material is removed from the global cold storage warehouse to the time the finished product is returned to the global warehouse for delivery to the market. Data points will be captured every time vaccine material is removed from cold storage during these processing steps.

CHAPTER 3: VALUE STREAM MAPPING (VSM)

In order to generate best practice recommendations for the strategic implementation of cold chain management MES, a thorough understanding of the manufacturing process from formulation to labeling will need to be acquired. The first tool used to gain this understanding was Material and Information Flow Mapping, which is more commonly known in industry as Value Stream Mapping (VSM).

3.1 VSM Description

Value Stream Mapping is a tool developed for the Toyota Production System. The tool is used by Toyota Production System practitioners to depict current events on the manufacturing floor and to design a lean future state of events on the manufacturing floor. A value stream is all of the actions, both value added and non-value added, required to deliver a product through the manufacturing site to the customer from raw material to the final product. Value-stream mapping is an exercise completed with paper and pencil that helps the user see and understand the flow of material and information as product travels through the manufacturing facility.

In their book *Learning to See, value-stream mapping to create value and eliminate muda*, Rother and Shook describe the objective of value-stream mapping:

“The purpose of value-stream mapping is to highlight sources of waste and eliminate them by implementation of a future-state value stream that can become a reality within a short period of time. The goal is to build a chain of production where the individual processes are linked to their customers either by continuous flow or pull, and each process gets as close as possible to producing only what its customers need when they need it.” (Rother & Shook, 2003)

Mapping allows the user to visualize the flow of material and information across all parts of the manufacturing process. Each step in the manufacturing process is documented as part of the value stream map. This technique provides a cross-functional look at the manufacturing flow across organizational boundaries. Analyzing processing across organizations prevents the user from being biased by the local goals of the isolated independent units. Once the current state mapping is complete, a future state map is devised, improving global flow instead of focusing on localized improvements that may be detrimental to the overall product goals. The ideal state of the manufacturing floor is then developed through

implementation plans that eliminate wastes such as overproduction, rework and inventory build. (Rother & Shook, 2003)

3.2 Findings from VSM

The initial attempt at understanding and improving cold chain management at the Rosia site using value stream mapping was unsuccessful. A great deal of time was spent on the manufacturing floor charting observations of material flow including the flow of bulk material in the warehouse, secondary product throughout manufacturing steps, and finished vaccine material to the shipping docks. Unfortunately, the observations did not lead to a map that clearly described concerns with cold chain management. The mapping was not going to yield a process improvement plan for cold chain monitoring that could be managed by MES.

Initiation of value stream mapping did yield some observations about the current paper-based cold chain management system. One benefit of the paper-based system is the flexibility of the system. Deviations that occur during processing can easily be managed by the paper-based system. An ideal automation solution must be sophisticated enough to handle a number of routine deviations from standard procedures that occur frequently in production. The next five figures will diagram vaccine material flow and some routine deviations from this flow that are easily managed by the paper-based system that must also be managed by the MES.

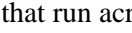
Figure 2 through Figure 6 have notation that indicates product movement, product processing and time out-of-refrigeration clock starts and stops. Arrows formed from solid lines () that lead from one storage location to another represent the transfer of material from a given location to another location. Arrows formed from dashed lines that are shaded on the inside () that run across processing steps represent the processing of material. Two symbols in these figures represent time out-of-refrigeration data that is recorded in paper documents. The letter "S" enclosed in a circle signifies a recorded TOR start time and the letter "E" enclosed in a circle signifies a recorded TOR end time. The presence of these two symbols signifies that time out-of-refrigeration data is recorded as soon as the material is removed from, or enters, the cold storage location. Each start time must be paired with an end time, with the end time appearing at the end of the series of product movement and product processing arrows.

The current state of typical vaccine product flow is diagramed in Figure 2. Bulk vaccine must proceed through four major processing areas before being sent to the market: 1) formulation & filling, 2) inspection, 3) labeling, and 4) packaging. Each of the processing steps can occur in different buildings on-site. The first step in the product flow is removing bulk vaccine from the global cold storage

warehouse and delivering it to a temporary cold storage warehouse just outside the formulation and filling lines. A small inventory of bulk vaccine is maintained in this temporary warehouse. The bulk vaccine is combined with stabilizers and possibly an adjuvant to enhance the immune response generated in patients. The formulated vaccine is then filled into vials or syringes, capped, and returned to the temporary cold storage warehouse. In order to demonstrate all possible movements of the material, a worst-case scenario for product flow, the filled vaccine is then returned to the global cold storage warehouse until it is needed for inspection. For the remainder of this product flow description, vaccine material will always be returned to the global warehouse after processing, representing a worst case scenario.

Figure 2: Vaccine Product Flow through Processing

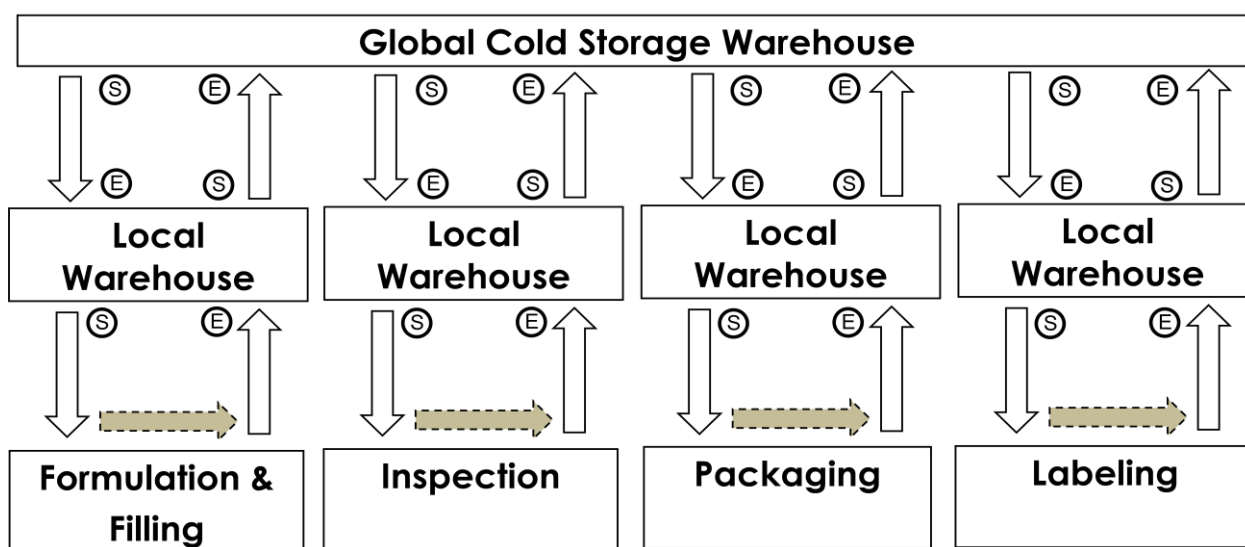

Filled vaccine is transferred to the temporary cold storage warehouse outside of the inspection area until the material is ready to be examined. The vaccine vials are then inspected manually or by automated equipment and are returned to the temporary storage warehouse. The inspected vaccine material is returned to the global cold storage warehouse and then sent to the temporary warehouse in the building where packaging of the inspected vials occurs. Material is staged from the local warehouse and the inspected vials or syringes are inserted into blister packaging and matched with inserts that include important information such as indications, usage, dosage, and warnings. Packaged vaccine lots are returned to the local cold storage warehouse and then sent to the global warehouse. The final stage in the typical vaccine product flow diagram involves transferring the packaged vials from the global warehouse to the temporary warehouse outside of the labeling area. Packaged vials are labeled for shipment to the customer and returned to the local warehouse before being sent to the global warehouse.

The first case the automation solution must be able to manage is when processing is interrupted, which is illustrated in Figure 3. Processing can be interrupted by machine failure, raw material depletion, unavailability of labor or a number of other issues. During the interruption, vaccine material is removed from the ambient temperature of the processing area and returned to the local cold storage warehouse. The time out-of-refrigeration calculation for the process must be stopped and then started again when the material remaining to be processed is removed from cold storage. Resuming processing could occur at any point in time in the future and during any processing step; formulation & filling is used as an example in Figure 3. Using a traditional paper-based system, the time the material has been entirely returned to the temporary cold storage warehouse is noted in the margins of the batch record. The time the first pallet of material is removed from the local warehouse is also recorded in the margin of the batch record. This additional data is used to calculate the time out-of-refrigeration for the lot of vaccine during this phase of the manufacturing process. In some sections of the batch record where mechanical failures are known to occur, additional space is provided for returning and recalling material from the temporary warehouse during production interruptions. The MES solution must be flexible enough to handle additional time stamps when vaccine material is returned to and recalled from the cold storage warehouse.

Figure 3: Process Interruption Disrupts Material Flow

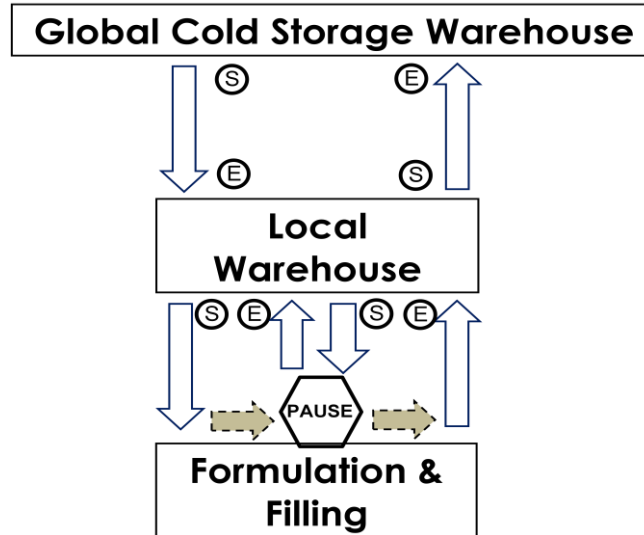

The next case the automation solution must be able to manage is when a lot of vaccine material is divided into two or more sections during processing, which is illustrated in Figure 4. Lots can be divided at the formulation & filling phase when material is designated to be shipped to a specific country. Individual regulatory agencies may not approve of a specific adjuvant or stabilizer in the vaccine recipe. In this case, the bulk lot is divided into portions and can be formulated and filled at different times. Lots

can also be divided at the packaging phase as specific regulatory agencies may require additional information in the medical insert or a special type of packaging. Each of these requests can divide a lot during processing. In Figure 4, the lot is divided at the inspection phase because one section of the lot will be evaluated manually, while another section of the lot will be evaluated by automated equipment.

Figure 4: Division of Material during Processing

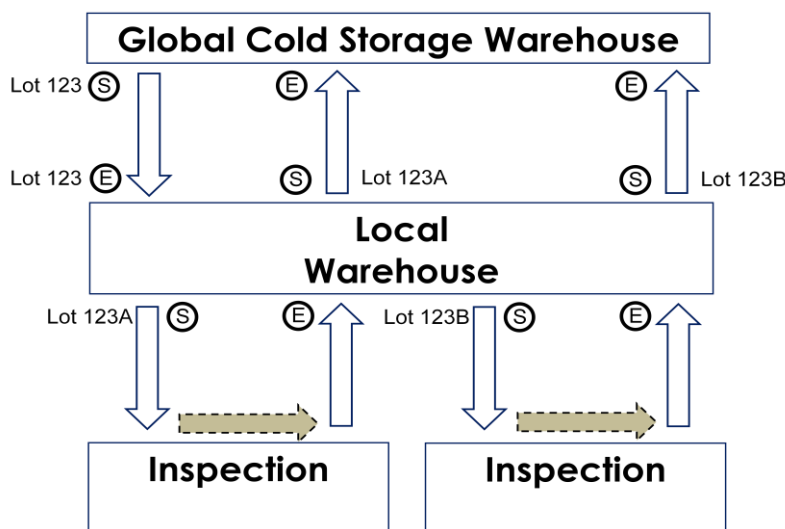

Before inspection begins, the EPR generates two separate orders from the lot of filled material. This instruction generates two paper batch records, one for each section of the divided lot. Time out-of-refrigeration data from the filled lot is transferred to each of the two new inspection batch records. The automation solution must be able to manage split lots during all phases of production. A link must be maintained connecting the time out-of-refrigeration data from the previous step with the time out-of-refrigeration data of the new process step pathways.

The next case the automation solution must be able to manage is when only part of the processing occurs at the Rosia site, which is illustrated in Figure 5. The Rosia site has facilities to complete all four of the major processing steps on-site, however, the V&D division is an expansive network with current processing facilities in Europe and the United States. Bulk vaccine is often formulated, filled, and inspected at another location and then shipped in cold storage vehicles to Rosia. Personnel at the Rosia site then package and label the material for local markets. Flexibility in the supply chain is a key part of Novartis' strategy to allow them to support the global marketplace, especially with time-sensitive vaccines such as the vaccine that protects against influenza.

Figure 5: Processing of Material at Numerous Facilities

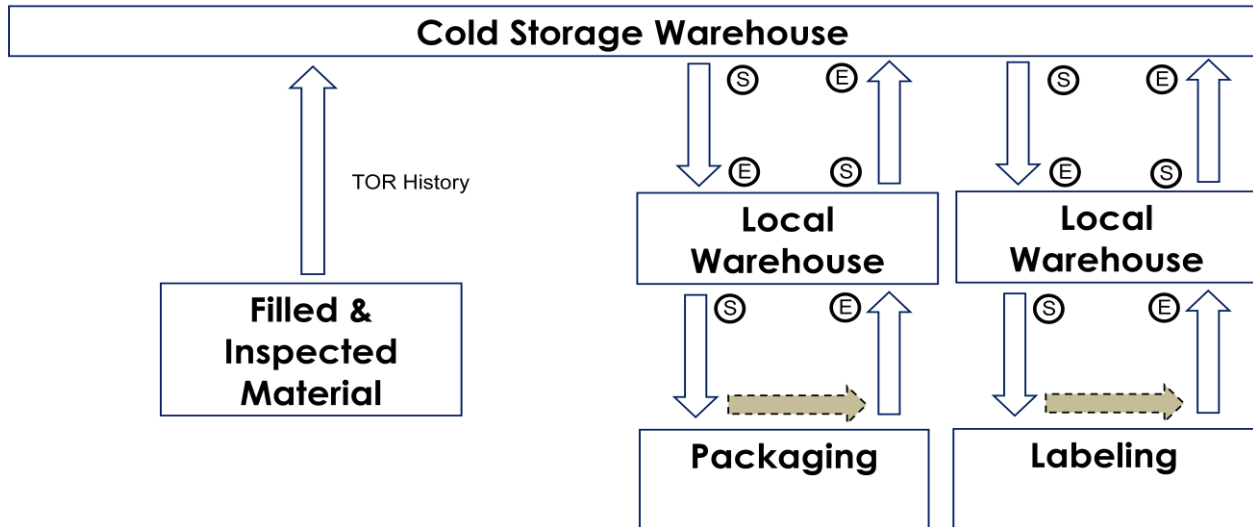

Material that arrives from another site has a time out-of-refrigeration history. This history must be able to be transferred electronically or entered manually into the cold chain MES solution. With the current paper-based system, the amount of time out-of-refrigeration from the previous processing steps that occurred at another facility is simply added to the local batch record.

The final case the automation solution must be able to manage is when processing is straight through and intermediate storage in a local warehouse is not required, which is illustrated in Figure 6. Material is not always returned to a local warehouse and then to the global warehouse before beginning the next phase of processing. Vaccine material sometimes starts a process such as formulation and filling and then is manually inspected before being sent directly to a packaging line. After packaging the material may remain in the local cold storage warehouse outside of packaging until it is delivered directly to labeling for processing.

The MES solution will have an underlying architecture that accounts for all of the possible production steps and transportation locations. The system must be able to automatically generate blank values when part of the established architecture is bypassed. The system must also be able to bring together start values from one processing step and end values from another processing step.

Figure 6: Straight Through Processing of Material

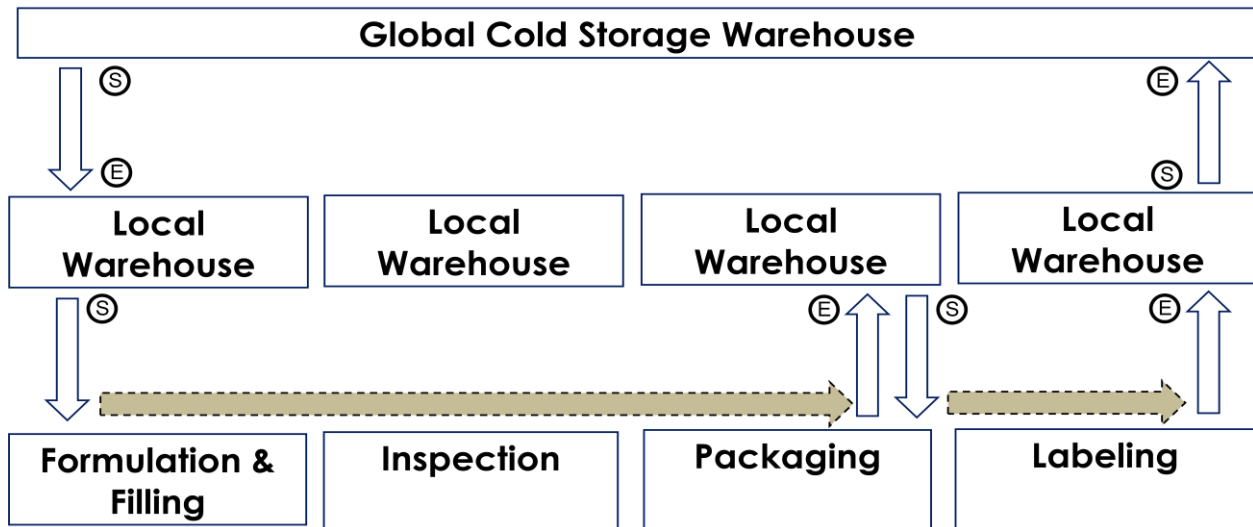

3.3 VSM Shortcomings for Understanding the Cold Chain

Value-stream mapping presented three difficulties in trying to understand and explain the cold chain management system at Rosia. First, value stream mapping is most effective when it is focused on one product or a family of products. In mapping the cold chain at Rosia, it was necessary to account for all vaccine product material flow. Next, value stream mapping is best when the manufacturing process flows are mature. The tracking of temperature-sensitive material is not centralized. Data for tracking time out-of-refrigeration is collected as a loose network of procedures and systems. Finally, important information tracked in a value stream map tells the reader what triggers the movement of product. Time out-of-refrigeration measurements and calculations do not trigger the movement of product.

According to Rother and Shook, “one point to understand clearly before starting [a value stream map] is the need to focus on one product family.” (Rother & Shook, 2003) Customers care about a specific product from the manufacturing facility so focusing on the flow of one product or family of products with similar processing and equipment use is critical to the end user. Mapping all products on the same map muddles the picture, preventing the user from clearly finding and eliminating wastes. A more appropriate tool for mapping the cold chain would allow the user to track the process by which all products are flowing through the cold chain network.

Value stream mapping is best executed when defined procedures guide material flow through the manufacturing site. While it is possible to go and see the movement of vaccine product in and out of cold storage units, the tracking of time out-of-refrigeration is guided by an informal network of emails and

phone calls. Mapping these communications in the context of a value stream map is difficult because they do not impact flow of material.

One goal of the future state value stream map is to highlight communications and information flow that signal the movement of material valued by the customer. Instructions from an enterprise resource planning system is one type of automated message that signals how much vaccine material should be processed during a given production step. The processing list generated by schedulers is a paper-based message that tells individual processing areas which raw materials they need to gather and prepare for the next few days of processing. These messages are a necessary part of the value-stream map because the communication tells each processing area what they should do in the next step of the process. Time out-of-refrigeration is a critical process parameter for vaccine material captured during processing, but it does not drive the movement of material. Time out-of-refrigeration data may shorten a processing window, but it does not tell production areas what raw materials are required for processing, what should be manufactured, or when manufacturing should be initiated. Time out-of-refrigeration information is a by-product of the manufacturing process and a more effective tool for mapping the cold chain would capture the generation and movement of this critical information.

CHAPTER 4: CURRENT-STATE INFORMATION PRODUCT MAPS (IP-MAPS)

4.1 IP-MAP Advantages for Understanding the Cold Chain

Data generated by a manufacturing process is often viewed as a by-product of production. Organizations instinctively focus their time and resources on improving the material being generated and not on improving the quality of critical data that supports processing. This data has a process flow similar to that the material with which is it associated. The end result of the data flow is information that customers find valuable. Customers consider end result data about product quality or safety just as important as the appearance of the finished good. In the case of vaccines, information derived from production data points provides insight into the quality, safety, and efficacy of the lot of material. These attributes are not only highly valued by the customer, but they are required by law for release and distribution of the product.





Focusing on data as a by-product can lead organizations to spend valuable resources on the system that controls the data instead of focusing on the product the data will deliver. Reliable information is critical to good decision making. The faster reliable, consistent data is available to the customer, the more value the customer will find in the relationship. High quality information is a competitive advantage that can keep customers loyal to a product and increase the value of the brand. One tool that can be used to focus an organization on the data generated by a process is the Information Product Map (IP-Map).

4.2 IP-Map Description

An IP-Map is a method for modeling the construction of an information product. Instead of considering data a by-product of production, this tool can be used to focus information as a product that has value to the customer. The tool uses inputs called data elements to generate outputs called information products. A data element is the smallest unit of named data that has meaning in the context of an operational environment. Examples of data elements include dates, times, names, deposits, or phone numbers. An information product is a collection of data element instances that meets the specified requirements of a data customer. Examples of information products include birth certificates, work permits, and financial statements. The IP-Map is a systematic representation of the process involved in creating an information product from the data elements (Lee, Pipino, Funk, & Wang, 2006).

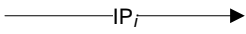
The guide to IP-Map symbols and representations presented in Figure 7 is consistent with standard conventions. These notations are found throughout the IP-Maps of this thesis.

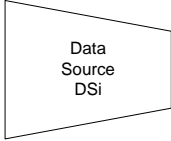
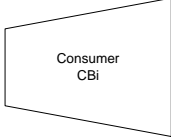
Figure 7: Information Product Map Symbol Guide

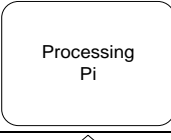
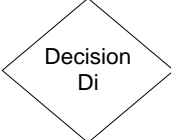
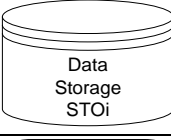
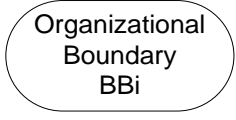
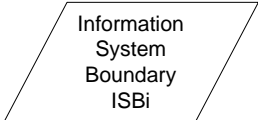
<i>Symbol</i>	<i>Definition/Purpose</i>
	<i>Raw Data</i> : A predefined set of data units that are used as the raw material in a process that will produce an information product.
	<i>Information Product</i> : A finalized collection of data produced by human, mechanical, or electronic effort for use by a data consumer.
	<i>Component Data</i> : A set of temporary, semi-processed information needed to manufacture the information product. Data generated within the IP-Map and used in creating the final information product.
	<i>Source (Raw Data) Block</i> : Represents the source of raw input data that must be available in order to produce the information product expected by the consumer.
	<i>Consumer (Output) Block</i> : Represents the consumer of the information product. The consumer defines in advance the data elements that constitute the finished information product.
	<i>Data Quality Block</i> : Represents the check for data quality in those items that are essential in producing defect-free information product. The block has two possible outputs, a correct stream and an incorrect stream.
	<i>Processing Block</i> : Represents the manipulation, combination, or calculation of raw or component data items and/or component data items used to calculate the information product.
	<i>Decision Block</i> : Represents the direction of data to a different set of blocks for processing, if necessary.
	<i>Data Storage Block</i> : Represents the capture of data items in storage files and databases so they can be available for further processing.
	<i>Business Boundary Block</i> : Represents instances where raw input or component data items are handed over by one organizational unit to another organizational unit.
	<i>Information System Boundary Block</i> : Reflects changes to raw or component data items as they move from one type of information system to another.

4.3 IP-Map Development Approach

Two important facets of proper treatment of information as a product are to understand the information needs of the customer and to manage information as the product of a well-defined production process. The procedure for generating the current state maps realized these points and closely followed the procedures suggestion by Lee, et al. in *Journey to Data Quality*.

1. *Choose the IP to be mapped. Choose the data elements that constitute the basic building blocks of the IP.* The total TOR for the finished vaccine product was selected as the IP to be mapped. This is the most important piece of information for the customer as it determines the efficacy of the product. The data elements are the times that product is removed from and entered into cold storage as the material is transferred and processed. These data points are used to calculate the information product. The number of data elements does not change in the current state and future state IP-Map because they are predefined and critical to the information product.
2. *Identify the data collector, the data custodian, and the data consumer.* Reviewing operating procedures and observing production steps allowed for the identification of who is creating, collecting, and entering data. In addition, information was collected about those who will use the data to generate the IP.
3. *Depict the IP by capturing the flows of the data elements, their transformations, and the connections between and among flows.* Reviewing operating procedures and observing data transfers between cold storage units and production allowed for the identification of data conversion and connections.
4. *Identify the functional roles. Identify the pertinent systems.* Interviewing operators and supervisors through the manufacturing site helped determine which departments were responsible for which processing steps when procedures were unclear. (Lee, Pipino, Funk, & Wang, 2006)

Once this information was collected, the current state IP-maps were generated. The first step in this process was outlining the physical work flow. When the physical (FDA, 2010)al work flow was outlined, the data flow was diagramed using the physical work flow as a skeleton for this process. Next, system infrastructures were added to the data flow mapping. Finally, the organizational infrastructure and roles were incorporated in the data flow map to create the final IP-Maps.

4.4 Current-State IP-Maps

4.4.1 Transfer of Bulk Material from the Global Warehouse to the Filling and Inspection Local Cold Room

The first process that was analyzed using IP-mapping was the raw data generated and manipulated as bulk vaccine material is transferred from the global cold storage warehouse to the local cold storage room outside of the filling area. Figure 8 shows the IP-Map generated by this process. In order to initiate movement of bulk vaccine, Checklist A is created by an operator from the shipping/receiving department (DOC1). The time the first container of bulk material is removed from the global warehouse is written in DOC1 by a shipping/receiving operator (RD1). The data is generated just outside the global cold storage warehouse (DS1) and DOC1 is attached to the first container of bulk vaccine removed from the global warehouse. The designated number of bulk vaccine containers are removed from the global cold storage warehouse and are transferred across an organizational boundary to the local cold storage warehouse outside of the filling area (BB1).

Figure 8: IP-Map for the Transfer of Bulk Material from the Global Warehouse to the Filling and Inspection Local Cold Room

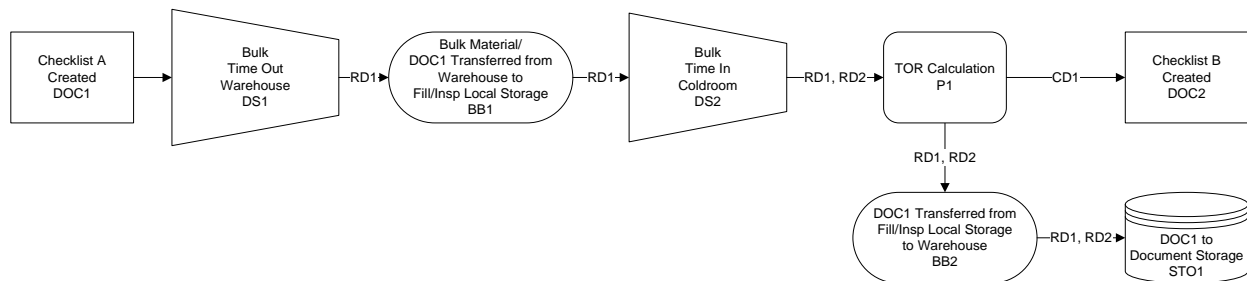

The checklist attached to the first pallet of bulk vaccine is removed by an operator from the filling/inspection area before the container enters the local warehouse. The time the last container of bulk material enters the local warehouse is written in DOC1 by a filling/inspection operator (RD2). The data is generated just outside the local cold storage room (DS2). The raw data generated in this process, RD1 and RD2, is used to calculate the time out-of-refrigeration for the transfer of bulk material from the global warehouse to the local cold storage outside the filling area (CD1). The calculation is captured by the P1 processing block and is completed by an operator from filling/inspection. Once the TOR calculation of P1 is complete, DOC1 is transferred back across an organizational boundary from the storage warehouse

outside of the filling area to the global warehouse (BB2). DOC1 is then stored by a shipping/receiving operator in a filing cabinet in the global warehouse (STO1).

The TOR data CD1 is transferred to Checklist B (DOC2). This document is created by an operator from the filling/inspection department and is attached to the last container of bulk material that entered the local cold storage outside the filling department. The document is used to capture information from the next two manufacturing processes, filling and inspection.

4.4.2 Filling and Inspection Processes

The second process that was analyzed using IP-mapping was the raw data generated and manipulated as bulk vaccine material is removed from containers, formulated with stabilizers and adjuvant, filled into vials or syringes, and inspected for quality issues. Figure 9 shows the IP-Map generated by these processes. DOC2 is removed from the last container of bulk material to enter the filling cold storage room and this document is used to record information for the next two processes. The first decision occurs once DOC2 is recovered; the processes of formulation/filling and inspection can either occur consecutively or intermittently. Filled material can proceed directly to an automated inspection line or it can be returned to the local cold storage site and manually inspected at a later time. Intermittent filling and inspection occurs when the production schedule for automated inspection lines is full or when the automated equipment is having mechanical difficulties.

Filling and inspection occurring consecutively will be discussed first. The bulk vaccine material is removed to DS2, the area just outside the local cold storage room. The time the first container of bulk material is removed from the local cold storage room is recorded in DOC2 by a filling operator (RD3). The designated number of bulk vaccine containers are removed from the local cold storage and are filled and inspected. During the course of these processes, a disruption can occur and all of the bulk vaccine containers, or filled pallets of secondary material depending on the time of the disruption, can be returned to the local cold storage warehouse. These steps do not always occur and are indicated by a dashed line in the IP-map. The time the last container of bulk material, or pallet of filled material, is returned to the local cold storage room is recorded in DOC2 by a filling/inspection operator (RD4). When processing is ready to continue, the time the first container of bulk vaccine or pallet of filled product is removed from local cold storage is recorded in DOC2 by a filling/inspection operator (RD5). When inspection is complete, the time the last pallet of filled/inspected product enters the cold room is recorded in DOC2 by an inspection operator (RD6). All of these raw data points are generated at DS2 just as material is either entering or leaving the local cold storage outside of the filling area.

Figure 9: IP-Map for the Filling and Inspection Processes

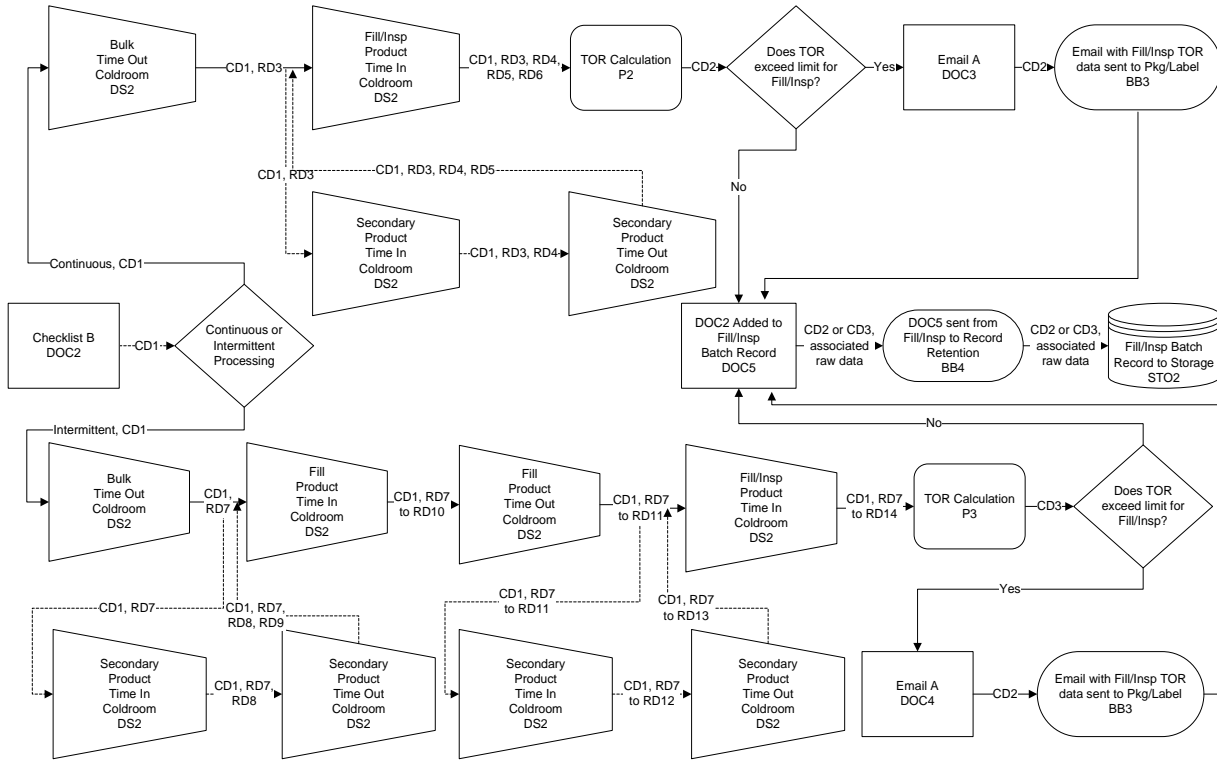

The raw data generated in this process, RD3 through RD6, and the TOR data from the transfer of bulk material, CD1, is used to calculate the time out-of-refrigeration for the continuous filling and inspection processes (CD2). The calculation is captured by the P2 processing block and is completed by an operator from filling/inspection. At this point the TOR data is reviewed against limits for these two processing steps. If the TOR limit was exceeded, an email is generated letting the supervisors of the next processing step, packaging, know they have less time to complete their phase of processing than expected (DOC3). The email transfers across an organizational boundary as it is sent from a filling/inspection supervisor to a packaging supervisor (BB3). DOC2 is then incorporated in the filling and inspection batch record (DOC5). If the TOR data is within the limits for filling and inspection, no email is sent to packaging and DOC2 is directly incorporated with the DOC5.

Filling and inspection occurring intermittently will be discussed next. The bulk vaccine material is removed to DS2, the area just outside the local cold storage room, for filling. The time the first container of bulk material is removed from the local cold storage room is recorded in DOC2 by a filling operator (RD7). The designated number of bulk vaccine containers are removed from the local cold storage and are filled. During the course of filling, a disruption can occur and all of the bulk vaccine containers can be returned to the local cold storage warehouse. These steps do not always occur and are

indicated by a dashed line in the IP-map. The time the last container of bulk material is returned to the local cold storage room is recorded in DOC2 by a filling operator (RD8). When processing is ready to continue, the time the first container of bulk vaccine is removed from the local cold storage is recorded in DOC2 by a filling operator (RD9). When filling is complete, the time the last pallet of filled product enters the cold room is recorded in DOC2 by a filling operator (RD10). All of these raw data points are generated at DS2 just as material is either entering or leaving the local cold storage outside of the filling area.

The filled vaccine material is next removed to DS2, the area just outside the local cold storage room. The time the first pallet of filled material is removed from the local cold storage room is recorded in DOC2 by an inspection operator (RD11). The designated number of filled vaccine pallets are removed from the local cold storage and are inspected. During the course of inspection, a disruption can occur and all of the filled pallets of secondary material can be returned to the local cold storage warehouse. These steps do not always occur and are indicated by a dashed line in the IP-map. The time the last pallet of filled material is returned to the local cold storage room is recorded in DOC2 by an inspection operator (RD12). When inspection is ready to continue, the time the first pallet of filled product is removed from local cold storage is recorded in DOC2 by an inspection operator (RD13). When inspection is complete, the time the last pallet of inspected product enters the cold room is recorded in DOC2 by an inspection operator (RD14). All of these raw data points are generated at DS2 just as material is either entering or leaving the local cold storage outside of the filling area.

The raw data generated in this process, RD7 through RD14, and the TOR data from the transfer of bulk material, CD1, is used to calculate the time out-of-refrigeration for the intermittent filling and inspection processes (CD3). The calculation is captured by the P3 processing block and is completed by an operator from filling/inspection. At this point the TOR data is reviewed against limits for these two processing steps. If the TOR limit was exceeded, an email is generated letting the supervisors of the next processing step, packaging, know they have less time to complete their phase of processing than expected (DOC4). The email transfers across an organizational boundary as it is sent from a filling/inspection supervisor to a packaging supervisor (BB3). DOC2 is then incorporated in the filling and inspection batch record (DOC5). If the TOR data is within the limits for filling and inspection, no email is sent to packaging and DOC2 is directly incorporated with the DOC5.

DOC5 with the incorporated DOC2, regardless of whether the filling and inspection steps occurred continuously or intermittently, is sent across an organizational boundary by an inspection

supervisor to a record retention supervisor in another building (BB4). The batch record is then stored in the record retention archive for at least one year after the expiry of the product (STO2) (FDA, 2010).

4.4.3 *Transfer of Filled/Inspected Product from the Filling and Inspection Local Cold Room to the Packaging and Labeling Local Cold Room*

The third process that was analyzed using IP-mapping was the raw data generated and manipulated as inspected and filled material is transferred from the local cold storage room outside of the filling area to the global cold storage warehouse. Filled/inspected inventory is maintained in the global warehouse until the end consumer country has been identified and the material is ready to be packaged and labeled. Figure 10 shows the IP-Map generated by this process. In order to initiate movement of filled/inspected material, Checklist A is created by an operator from the filling/inspection department (DOC6). The time the first pallet of inspected material is removed from the local cold room is written in DOC6 by a filling/inspection operator (RD15). The data is generated just outside the global cold storage warehouse (DS2) and DOC6 is attached to the first pallet of inspected material removed from the local cold room. The designated number of pallets of filled/inspected material are removed from the local cold room outside of the filling area and are transferred across an organizational boundary to the global warehouse (BB2).

Figure 10: IP-Map for the Transfer of Filled/Inspected Product from the Filling and Inspection Local Cold Room to the Packaging and Labeling Local Cold Room

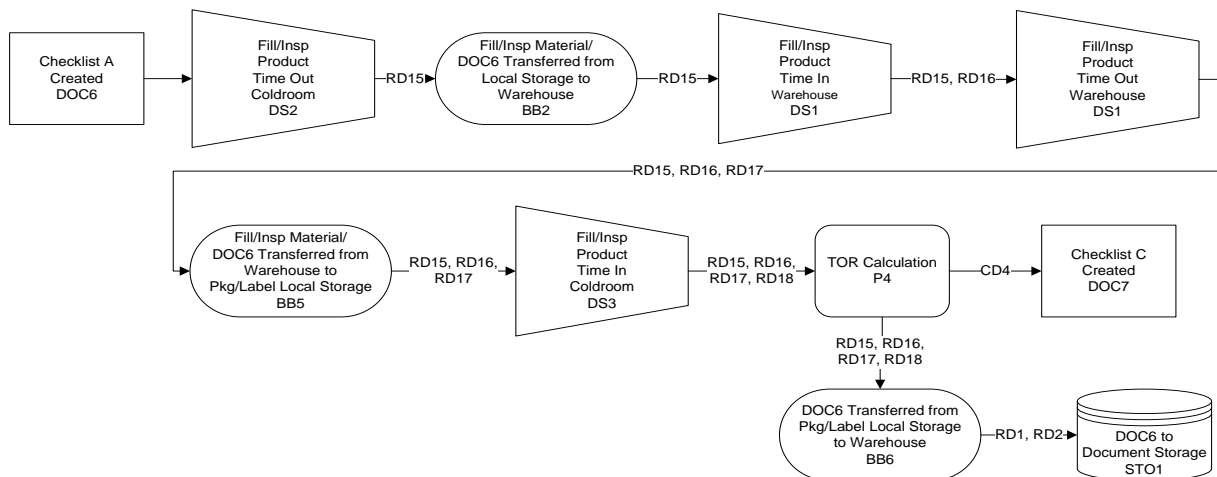

The checklist attached to the first pallet of filled/inspected material is removed by an operator from the global warehouse before the pallet enters the warehouse. The time the last pallet of filled/inspected material enters the global warehouse is written in DOC6 by a global warehouse operator

(RD16). The data is generated just outside the global warehouse (DS1). DOC6 is attached to the last pallet of filled/inspected material to enter the global warehouse and remains there until the material is ready for further processing. Once the material is ready to be transferred to the local warehouse outside of the packaging area, DOC6 is retrieved from the last pallet of material by a global warehouse operator.

The time the first pallet of filled and inspected material is removed from the global warehouse is written in DOC6 by a shipping/receiving operator (RD17). The data is generated just outside the global cold storage warehouse (DS1) and DOC6 is attached to the first pallet of filled/inspected material removed from the global warehouse. The designated number of filled/inspected pallets of material are removed from the global cold storage warehouse and are transferred across an organizational boundary to the local cold storage warehouse outside of the packaging area (BB5).

The checklist attached to the first pallet of filled/inspected material is removed by an operator from the packaging/labeling area before the pallet enters the local warehouse. The time the last pallet of filled/inspected material enters the local warehouse is written in DOC6 by a packaging/labeling operator (RD18). The data is generated just outside the local cold storage room (DS3). The raw data generated in this process, RD15 through RD18, is used to calculate the time out-of-refrigeration for the transfer of material from the local cold storage site outside the filling area to the local cold storage site outside the packaging area via the global warehouse (CD4). The calculation is captured by the P4 processing block and is completed by an operator from packaging/labeling. Once the TOR calculation of P4 is complete, DOC6 is transferred back across an organizational boundary from the storage warehouse outside of the packaging area to the global warehouse (BB6). DOC6 is then stored by a shipping/receiving operator in a filing cabinet in the global warehouse (STO1).

The TOR data CD4 is transferred to Checklist C (DOC7). This document is created by an operator from the packaging/labeling department and is attached to the last pallet of filled/inspected material that entered the local cold storage outside the packaging department. The document is used to capture information from the next two manufacturing processes, packaging and labeling.

4.4.4 Packaging and Labeling Processes

The fourth process that was analyzed using IP-mapping was the raw data generated and manipulated as filled/inspected material is removed from pallets, set into blister packaging, matched with safety and use instructions, and labeled. Figure 11 shows the IP-Map generated by these processes. DOC7 is removed from the last pallet of filled/inspected material to enter the packaging cold storage room and this document is used to record information for the next two processes. If the processing steps of filling

and inspection exceeded their time out-of-refrigeration, the amount of time that exceeded the alarm limit is added to DOC7 by way of the email DOC3 or DOC4. After this TOR data is potentially added to DOC7, a decision occurs; the processes of packaging and labeling can either occur consecutively or intermittently. Packaged material can proceed directly to an automated labeling line or it can be returned to global warehouse and labeled at a later time once the destination country of the customer is known. Continuous processing is usually selected if a TOR alarm limit was exceeded in a previous process. Continuous process takes less time out-of-refrigeration and allows for the entire batch to remain under its overall TOR alarm limit.

Figure 11: IP-Map for the Packaging and Labeling Processes

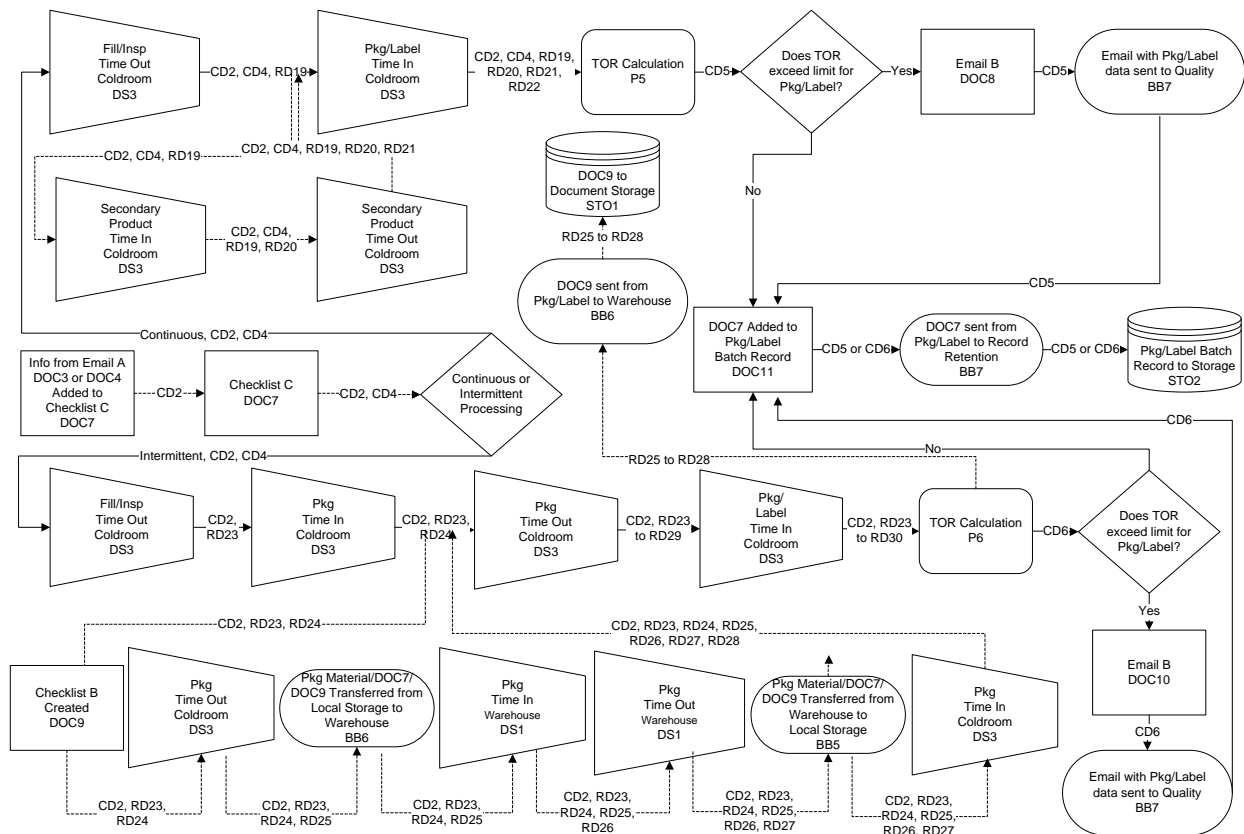

Packaging and labeling occurring consecutively will be discussed first. The filled/inspected material is removed to DS3, the area just outside the local cold storage room. The time the first pallet of filled/inspected material is removed from the local cold storage room is recorded in DOC7 by a packaging operator (RD19). The designated number of filled/inspected vaccine pallets are removed from the local cold storage and are packaged and labeled. During the course of these processes, a disruption can occur and all of the filled/inspected pallets, or packaged pallets depending on the time of the disruption, can be

returned to the local cold storage warehouse. These steps do not always occur and are indicated by a dashed line in the IP-map. The time the last pallet of filled/inspected material, or pallet of packaged material, is returned to the local cold storage room is recorded in DOC7 by a packaging/labeling operator (RD20). When processing is ready to continue, the time the first pallet of filled/inspected material or pallet of packaged material is removed from local cold storage is recorded in DOC7 by a packaging/labeling operator (RD21). When labeling is complete, the time the last pallet of packaged/labeled product enters the cold room is recorded in DOC7 by a labeling operator (RD22). All of these raw data points are generated at DS3 just as material is either entering or leaving the local cold storage outside of the packaging area.

The raw data generated in this process, RD19 through RD22, the TOR data from the filling and inspection processes, CD2, and TOR data from the transfer of filled/inspected product, CD4, is used to calculate the time out-of-refrigeration for the continuous packaging and labeling processes (CD5). The calculation is captured by the P5 processing block and is completed by an operator from packaging/labeling. At this point the TOR data is reviewed against limits for these two processing steps. If the TOR limit was exceeded, an email is generated letting the quality group know the batch has exceeded its TOR limit (DOC8). The email transfers across an organizational boundary as it is sent from a packaging/labeling supervisor to personnel in the quality department (BB7). DOC7 is then incorporated in the packaging and labeling batch record (DOC11). If the TOR data is within the limits for packaging and labeling, no email is sent to the quality group and DOC7 is directly incorporated with the DOC11.

Packaging and labeling occurring intermittently will be discussed next. Filled/inspected material is removed to DS3, the area just outside the local cold storage room, for packaging. The time the first pallet of filled/inspected material is removed from the local cold storage room is recorded in DOC7 by a packaging operator (RD23). Once packaging is complete, the time the last pallet of packaged material is returned to the local cold room is recorded in DOC7 by a packaging operator (RD24). In between the packaging and labeling steps, the material can be returned to the global warehouse for long term storage prior to labeling and shipping.

In order to initiate the transfer of packaged product back to the global warehouse for long term storage, Checklist A is created by an operator in the packaging area (DOC9). DOC7 and DOC9 now travel together but all data generated from the transfer of material to and from the global warehouse is documented in DOC9. These steps do not always occur and are indicated by a dashed line in the IP-map. The time the first pallet of packaged material is removed from the local cold room is written in DOC9 by a packaging operator (RD25). The data is generated just outside the local cold storage (DS3). DOC9 and

DOC7 are attached to the first pallet of packaged material removed from the local cold room. The designated number of pallets of packaged material are removed from the local cold room outside of the packaging area and are transferred across an organizational boundary to the global warehouse (BB6).

DOC7 and DOC9 are removed from the first pallet of packaged material by an operator from the global warehouse before the pallet enters the warehouse. The time the last pallet of packaged material enters the global warehouse is written in DOC9 by a global warehouse operator (RD26). The data is generated just outside the global warehouse (DS1). DOC7 and DOC9 are attached to the last pallet of packaged material to enter the global warehouse and they remain there until the material is ready for further processing. Once the material is ready to be transferred to the local warehouse outside of the packaging area, DOC7 and DOC9 are retrieved from the last pallet of material by a global warehouse operator.

The time the first pallet of packaged material is removed from the global warehouse is written in DOC9 by a warehouse operator (RD27). The data is generated just outside the global cold storage warehouse (DS1). DOC7 and DOC9 are attached to the first pallet of packaged material removed from the global warehouse. The designated number of pallets of packaged material are removed from the global cold storage warehouse and are transferred across an organizational boundary to the local cold storage warehouse outside of the packaging area (BB5).

The checklist attached to the first pallet of packaged material is removed by an operator from the packaging/labeling area before the pallet enters the local warehouse. The time the last pallet of packaged material enters the local warehouse is written in DOC9 by a packaging/labeling operator (RD28). The data is generated just outside the local cold storage room (DS3). When labeling is ready to be initiated, the time the first pallet of packaged material is removed from the local cold storage is recorded in DOC7 by a packaging/labeling supervisor (RD29). When labeling is complete, the time the last pallet of packaged/labeled product enters the cold room is recorded in DOC7 by a labeling operator (RD30). These raw data points are generated at DS3 just as material is either entering or leaving the local cold storage outside of the packaging area.

The raw data generated in this process, RD23 through RD30, is used to calculate the time out-of-refrigeration for intermittent packaging and labeling processes (CD6). The calculation is captured by the P6 processing block and is completed by an operator from packaging/labeling. At this point the TOR data is reviewed against limits for these two processing steps. If the TOR limit was exceeded, an email is generated letting the quality group know the batch has exceeded its TOR limit (DOC10). The email transfers across an organizational boundary as it is sent from a packaging/labeling supervisor to personnel

in the quality department (BB7). DOC7 is then incorporated in the packaging and labeling batch record (DOC11). If the TOR data is within the limits for packaging and labeling, no email is sent to the quality group and DOC7 is directly incorporated with the DOC11. After the TOR calculation at P6, DOC9 is sent across an organizational boundary from the packaging/labeling department to the warehouse (BB6). DOC9 is then stored by a shipping/receiving operator in a filing cabinet in the global warehouse (STO1).

DOC11 with the incorporated DOC7, regardless of whether the filling and inspection steps occurred continuously or intermittently, is sent across an organizational boundary by a labeling supervisor to a record retention supervisor in another building (BB7). The batch record is then stored in the record retention archive for at least one year after the expiry of the product (STO2) (FDA, 2010).

4.4.5 *Transfer of Finished Product from the Packaging and Labeling Local Cold Room to the Global Warehouse*

The fifth process that was analyzed using IP-mapping was the raw data generated and manipulated as finished product is transferred from the local cold storage room outside of the packaging area to the global cold storage warehouse for shipping. Figure 12 shows the IP-Map generated by this process. In order to initiate movement of the finished product, Checklist A is created by an operator from the packaging/labeling department (DOC12). The time the first pallet of finished material is removed from the local cold room is written in DOC12 by a packaging/labeling operator (RD31). The data is generated just outside the local cold storage room outside the packaging area (DS3) and DOC12 is attached to the first pallet of finished product removed from the local cold room. The designated number of pallets of finished material are removed from the local cold room outside of the packaging area and are transferred across an organizational boundary to the global warehouse (BB5).

Figure 12: IP-Map for the Transfer of Finished Product from the Packaging and Labeling Local Cold Room to the Global Warehouse

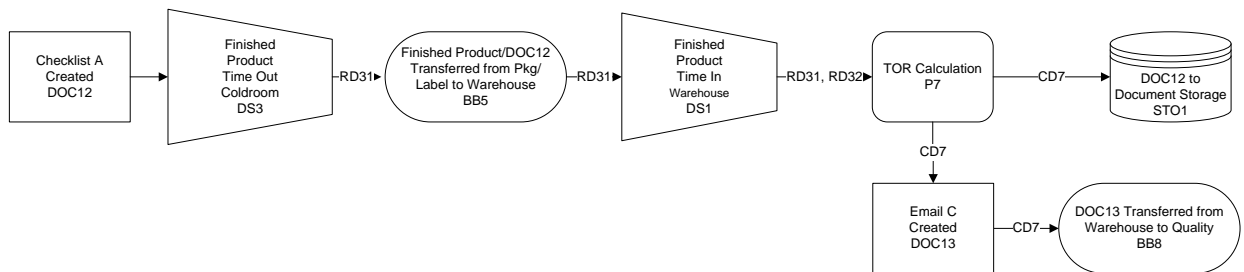

The checklist attached to the first pallet of finished material is removed by an operator from the global warehouse before the pallet enters the warehouse. The time the last pallet of finished material enters the global warehouse is written in DOC12 by a global warehouse operator (RD32). The data is generated just outside the global warehouse (DS1). The finished product is now managed by a set of procedures outside of the scope of this project as it waits to be shipped to a customer. The raw data generated in this process, RD31 and RD32, is used to calculate the time out-of-refrigeration for the transfer of finished material from the local cold storage outside the packaging area to the global warehouse (CD7). The calculation is captured by the P7 processing block and is completed by an operator from the global warehouse. Once the TOR calculation of P7 is complete, DOC12 is stored by a shipping/receiving operator in a filing cabinet in the global warehouse (STO1). An operator from the warehouse also generates an email with the TOR total calculated in P7 (DOC13). The email is sent across an organizational boundary from the warehouse to a quality supervisor (BB8).

4.4.6 Finished Product Time Out-of-Refrigeration Data Review

The final process that was analyzed using IP-mapping was the quality review of TOR data for the finished vaccine product. Figure 13 shows the IP-Map generated by this process. A quality supervisor collects the TOR data from the final transfer of finished product to the global warehouse (DOC12), from the filling/inspection batch record (DOC5), and from the packaging/labeling batch record (DOC11). The TOR calculation from DOC12, from the filling/inspection batch record, and from the packaging/labeling batch record is checked by a quality supervisor against the associated raw data and calculations (QC1, QC2, QC3). DOC8, DOC10, and DOC13 are emails from processing supervisors to the quality department to inform them that the finished product has exceeded its TOR limit. These emails are used as a warning system. Quality supervisors review the raw data of DOC12, DOC5, and DOC11 to verify the TOR calculations from the major processing steps. If there are any irregularities with the raw data entries or with the calculations associated with the quality checks of DOC12, DOC5, or DOC11, and investigation is opened by the quality department to resolve these issues (DOC13, DOC14, DOC15).

Once the TOR calculations from DOC12, DOC5, and DOC11 are verified, this data is then used to calculate an overall time out-of-refrigeration for the finished vaccine lot (CD8). The calculation is captured by the P8 processing block and is completed by a quality supervisor. The “*” associated with the component data inputs to P8 indicates that the values might be different from the starting value of CD7, CD2 or CD3, and CD5 or CD6 if a quality investigation is required and confirms an incorrect data entry or manipulation. The overall TOR for the finished product is one component of the release status for the lot of material. If the TOR for the finished lot exceeds the overall TOR limit, an investigation is initiated

by the quality department (DOC13). The finished material is placed into quarantine and cannot be released to consumers until the quality investigation is completed, and the material deemed safe for release. If the TOR limit for the finished product cannot be justified through additional stability studies, the material must be discarded.

Figure 13: IP-Map for the Finished Product Time Out-of-Refrigeration Data Review

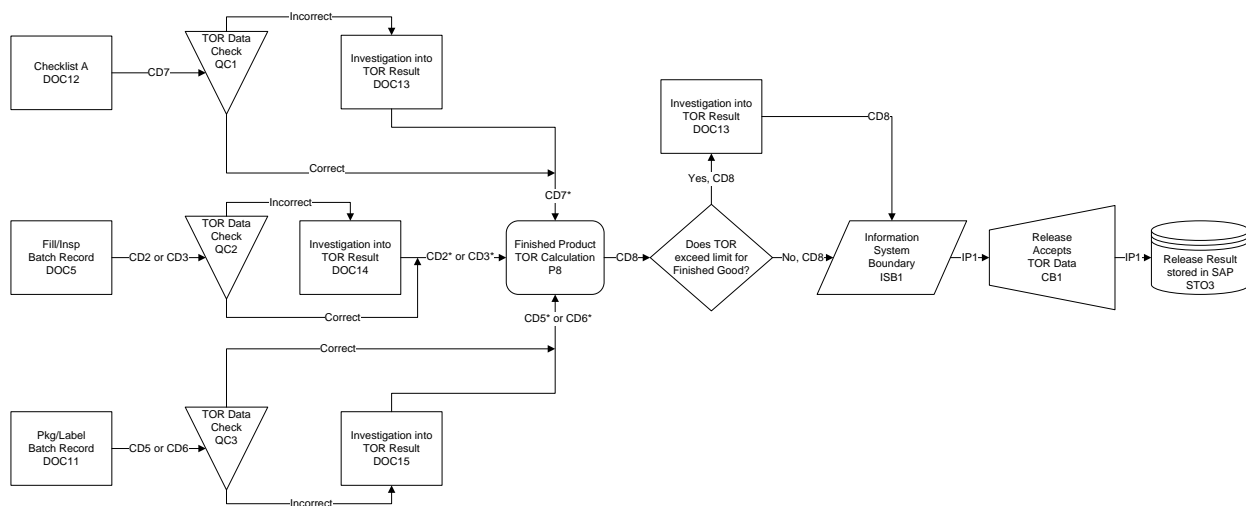

After the investigation is completed and approved by the quality department, the overall TOR data for the finished product crosses an information system boundary. The overall TOR for the finished product is transferred from paper to an electronic database (ISB1). The customer for the final information product is the product release department. The release department awaits the final electronic version of the TOR data which is the quality-checked paper-based TOR calculation, CD8, entered into the electronic database (IP1). Once the information product is complete, it is accepted by the release group (CB1). The final information product is stored in an electronic database for ease of access in the future (STO3). If the overall TOR for the finished product is within the overall TOR limit, the data directly crosses the information system boundary into the electronic database. The finished product is now one step closer to being released to consumers.

4.5 Cold Chain Management Concerns Identified by the IP-Maps

The current state IP-Maps reveal a number of important facts about the total TOR calculation for finished vaccine material. These IP-Maps highlight the transfer of information across organizational boundaries, the generation of emails to transfer data and notify supervisors of exceeded TOR limits, and

the need to quality check data and calculations. Each of these facts jeopardizes the integrity of the data used to generate the final information product, total TOR for the finished vaccine material.

When data travels across organizational boundaries, the chance of losing or damaging the data is high. Individuals responsible for the integrity of the data must ensure that the documents containing the data are delivered and received appropriately. Documents that contain critical data can easily be lost or misplaced in the hectic pace of the manufacturing floor. Movement of the data also increases the risk of the data being altered or destroyed accidentally. Data sheets are susceptible to tears, rips, stains, and other forms of permanent damage. Supervisors take great care to ensure that procedures are in place for the safe transfer of documents that contain data.

Data generated in the current cold chain travels across organizational boundaries a minimum of nine times throughout processing. Data physically moves along with the documents in which it is recorded. The documents travel from the global warehouse to the local cold storage room outside of filling, from the local cold storage room outside filling to the local cold storage room outside packaging, and from the local cold storage room outside packaging to the global warehouse. Documents are also compiled with batch records and transferred from production areas to designated document retention areas. During the physical transfer of material, associated documents could be misplaced as they travel across the site and between buildings.

Documents that travel with product are usually attached to a pallet of product during relocation. When pallets of material are removed from one cold storage site and sent to another cold storage site, the time the first pallet of material is removed from cold storage is written in the associated document and the document is attached to the first pallet. When the first pallet of material arrives at the desired cold storage location, the document containing data is removed from that pallet and held by an operator in the area. The operator passes the document onto another operator if their shift ends or if they need to leave the area for another reason. Once the last pallet of material enters the cold storage area, an operator in that area writes down the time the last pallet entered the cold room in the document. If additional TOR data needs to be added to the document, the document is attached to the last pallet that entered cold storage.

The document remains attached to the last pallet of material until that material is ready for further processing. Once the material is going to be further processed, the document needs to be retrieved from inside cold storage. Over time, pallets of material are moved around inside the cold storage unit. Finding the pallet with the data can be a time consuming process that often requires a great deal of rearranging product in the warehouse to get to the required documents.

When TOR alarms occur in processing, the supervisor in the area where the deviation occurred is required to notify the supervisor of the next processing step about the alarm. The amount of time that exceeds the TOR limit from the processing step is passed onto the next processing step. This information is communicated via email from the processing supervisor where the alarm occurred to the processing supervisor of the next manufacturing step. For example, assume the TOR for all processes up to inspection is three hours greater than the alarm limit. According to procedure, the inspection supervisor generates an email for the packaging supervisor letting the packaging supervisor know that the product has exceeded its TOR limit and that the packaging and labeling steps have three less hours to be completed. The packaging supervisor is now responsible for ensuring this information is included in the documents that capture TOR data for packaging and labeling.

Usually the filled/inspected material would be packaged and labeled shortly after the inspection step is complete. However, there are some instances when a mechanical failure occurs causing delays in the production schedule. Additionally, an unforeseen shortage in another product line could cause the shared package and labeling lines to have a full schedule. The filled/inspected material that has exceeded its TOR alarm limit by 3 hours will not be scheduled for packaging and labeling for many months. The supervisor who received the TOR alarm email must remember the alarm or risk exceeding the TOR limit for the finished material. Alternatively, the supervisor could go back to the batch record and review the TOR for the lot to see if there was an alarm, but this is a time consuming process that requires walking across the site, getting access to the retention area, finding the appropriate document, and reviewing the data.

The fact that data is manually entered into documents means that a quality check of the data must occur before the product is released to consumers. Additionally, calculations are completed manually and these must also be checked by a quality supervisor. Because all data is entered and manipulated manually, and this data is not converted across an information system boundary to an automated system, there is no real time monitoring of the data. All monitoring of time out-of-refrigeration data during processing is completed using cumbersome data retrievals from paper sources. Personnel from quality or release that may be interested in the time out-of-refrigeration of a particular lot would need to find the associated documents in production or contact supervisors responsible for the data. Decisions that require immediate data checks have to be delayed until the required information is gathered.

CHAPTER 5: FUTURE-STATE INFORMATION PRODUCT MAPS (IP-MAPS)

5.1 Future-State IP-Maps

Implementation of MES has the potential to eliminate concerns about data integrity associated with the current paper-based cold chain management system. The following future-state IP-Maps diagram the flow of information used to create an information product if MES were managing the cold chain. The flow of product is not changed in any way during this exercise. The only difference is how the MES manage the flow of information, creating value for the customer.

5.1.1 Transfer of Bulk Material from the Global Warehouse to the Filling and Inspection Local Cold Room

The first process that received a future-state IP-map was the raw data generated and manipulated as bulk vaccine material is transferred from the global cold storage warehouse to the local cold storage room outside of the filling area. Figure 14 shows the future state IP-Map for this process. In order to initiate movement of bulk vaccine, a worksheet associated with product transfer is generated in the MES by a planner (DOC1). The time the container of bulk material is removed from the global warehouse is automatically recorded in DOC1 by an automated tagging system (RD1). The data is generated as the container passes through the door of the global cold storage warehouse (DS1). The time the container of bulk material enters the local warehouse outside the filling area is automatically recorded in DOC1 by an automated tagging system (RD2). The data is generated as the container passes through the door of the local cold storage area (DS2). The MES system calculates the time out-of-refrigeration for the container of bulk material (CD1). The calculation is captured by the P1 processing block. The TOR data for the bulk container is stored in a database and this information can be viewed by anyone who has access to the MES interface.

Figure 14: Future-State IP-Map for the Transfer of Bulk Material from the Global Warehouse to the Filling and Inspection Local Cold Room

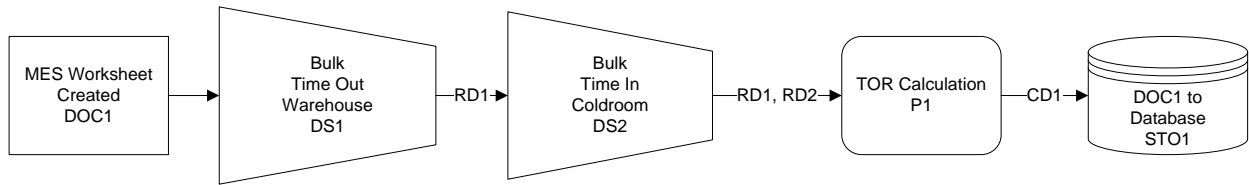

5.1.2 Filling and Inspection Processes

The second process that received a future-state IP-map was the raw data generated and manipulated as bulk vaccine material is removed from containers, formulated with stabilizers and adjuvant, filled into vials or syringes, and inspected for quality issues. Figure 15 shows the future-state IP-Map generated by these processes. In order to initiate processing of bulk vaccine, a worksheet associated with the filling and inspection processes is generated in the MES by a filling/inspection supervisor (DOC2). This worksheet electronically links the TOR data from the bulk containers to the TOR data of the associated filling and inspection pallets. The first decision occurs once DOC2 is generated; the processes of formulation/filling and inspection can either occur consecutively or intermittently.

Filling and inspection occurring consecutively will be discussed first. The time the bulk vaccine container is removed from the local cold room is automatically recorded in DOC2 by an automated tagging system (RD3). The data is generated as the container passes through the door of the local cold room (DS2). During the course of these processes, a disruption can occur and all of the bulk vaccine containers, or filled pallets of secondary material depending on the time of the disruption, can be returned to the local cold storage warehouse. These steps do not always occur and are indicated by a dashed line in the IP-map. The time the container of bulk material, or pallet of filled material, is returned to the local cold storage room is automatically recorded in DOC2 (RD4). When processing is ready to continue, the time the container of bulk vaccine or pallet of filled product is removed from local cold storage is automatically recorded in DOC2 (RD5). When inspection is complete, the time the pallet of filled/inspected product enters the cold room is automatically recorded in DOC2 (RD6). RD4, RD5, and RD6 are recorded in DOC2 by an automated tagging system at DS2 just as material passes through the door of the local cold storage outside of the filling area.

Figure 15: Future-State IP-Map for the Filling and Inspection Processes

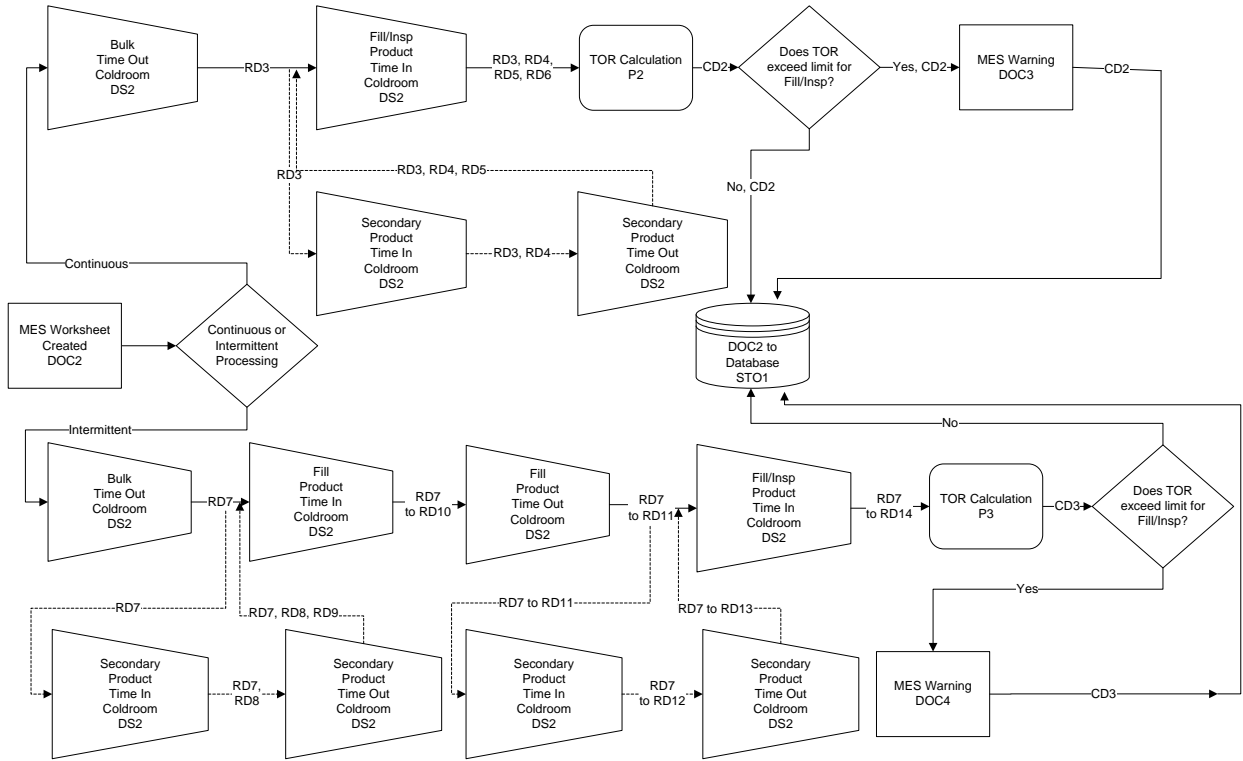

The MES uses the raw data generated in this process, RD3 through RD6, to calculate the time out-of-refrigeration for the continuous filling and inspection processes (CD2). The calculation is captured by the P2 processing block. The TOR data for the filling and inspection processes is reviewed against limits for these two processing steps. If the TOR limit was exceeded, a warning is generated in the MES (DOC3). Before the packaging supervisor can generate a worksheet for processing the filled/inspected pallet, they must acknowledge in the MES that the TOR alarm limit for the packaging and labeling processes will be shorter based on the previous deviation. Quality supervisors with access to the MES will be able to track the lot closely and put measures in place to prevent the lot from exceeding its TOR limit. If the TOR data is within the limits for filling and inspection, no warning is generated in the MES system. The TOR data for the filled/inspected pallet is stored in a database and this information can be viewed by anyone who has access to the MES interface (STO1).

Filling and inspection occurring intermittently will be discussed next. The time the bulk vaccine container is removed from the local cold room is automatically recorded in DOC2 by an automated tagging system (RD7). The data is generated as the container passes through the door of the local cold room (DS2). During the course of filling, a disruption can occur and all of the bulk vaccine containers can be returned to the local cold storage warehouse. These steps do not always occur and are indicated by a

dashed line in the IP-map. The time the container of bulk material is returned to the local cold storage room is automatically recorded in DOC2 (RD8). When processing is ready to continue, the time the container of bulk vaccine is removed from local cold storage is automatically recorded in DOC2 (RD9). When filling is complete, the time the pallet of filled product enters the cold room is automatically recorded in DOC2 (RD10). Raw data points RD7 through RD10 are recorded in DOC2 by an automated tagging system at DS2 just as material passes through the door of the local cold storage outside of the filling area.

The time the filled vaccine pallet is removed for inspection from the local cold room is automatically recorded in DOC2 by an automated tagging system (RD11). During the course of filling, a disruption can occur and all of the filled vaccine pallets can be returned to the local cold storage warehouse. These steps do not always occur and are indicated by a dashed line in the IP-map. The time the pallet of filled material is returned to the local cold storage room is automatically recorded in DOC2 (RD12). When inspection is ready to continue, the time the pallet of filled material is removed from local cold storage is automatically recorded in DOC2 (RD13). When filling is complete, the time the pallet of filled product enters the cold room is automatically recorded in DOC2 (RD14). Raw data points RD11 through RD14 are recorded in DOC2 by an automated tagging system at DS2 just as material passes through the door of the local cold storage outside of the filling area.

The MES uses the raw data generated in this process, RD7 through RD14, to calculate the time out-of-refrigeration for the intermittent filling and inspection processes (CD3). The calculation is captured by the P3 processing block. The TOR data for the filling and inspection processes is reviewed against limits for these two processing steps. If the TOR limit was exceeded, a warning is generated in the MES (DOC4). Before the packaging supervisor can generate a worksheet for processing the filled/inspected pallet, they must acknowledge in the MES that the TOR alarm limit for the packaging and labeling processes will be shorter based on the previous deviation. Quality supervisors with access to the MES will be able to track the lot closely and put measures in place to prevent the lot from exceeding its TOR limit. If the TOR data is within the limits for filling and inspection, no warning is generated in the MES system. The TOR data for the filled/inspected pallet is stored in a database and this information can be viewed by anyone who has access to the MES interface (STO1).

5.1.3 *Transfer of Filled/Inspected Product from the Filling and Inspection Local Cold Room to the Packaging and Labeling Local Cold Room*

The third process that received a future state IP-map was the raw data generated and manipulated as inspected and filled material is transferred from the local cold storage room outside of the filling area to the global cold storage warehouse. Filled/inspected inventory is maintained in the global warehouse until the end consumer country has been identified and the material is ready to be packaged and labeled. Figure 16 shows the future-state IP-Map generated by this process.

Figure 16: Future-State IP-Map for the Transfer of Filled/Inspected Product from the Filling and Inspection Local Cold Room to the Packaging and Labeling Local Cold Room

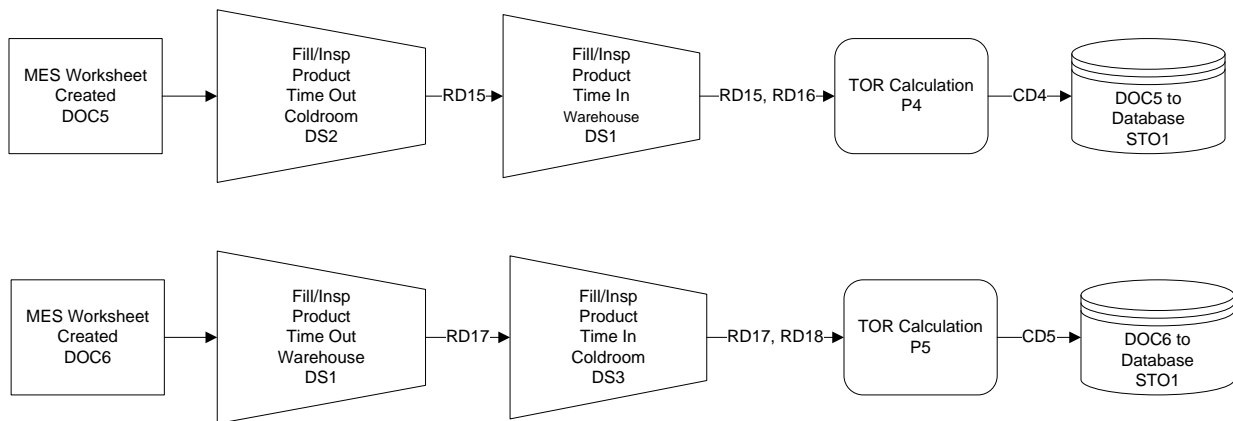

In order to initiate movement of filled/inspected material, a worksheet associated with product transfer is generated in the MES by a planner (DOC5). The time the pallet of filled/inspected material is removed from the local cold room is automatically recorded in DOC5 by an automated tagging system (RD15). The data is generated as the pallet passes through the door of the local cold room outside of the filling area (DS2). The time the pallet of filled/inspected material enters the global warehouse is automatically recorded in DOC5 by an automated tagging system (RD16). The data is generated as the container passes through the door of the global warehouse (DS1). The MES system calculates the time out-of-refrigeration for the pallet of filled/inspected material (CD4). The calculation is captured by the P4 processing block. The TOR data for the filled/inspected pallet is stored in a database and this information can be viewed by anyone who has access to the MES interface (STO1).

The transfer of filled/inspected material from the global warehouse for packaging and labeling is also tracked by the MES. A worksheet associated with product transfer is generated in the MES by a

planner to initiate this movement (DOC6). The time the pallet of filled/inspected material is removed from the global warehouse is automatically recorded in DOC6 by an automated tagging system (RD17). The data is generated as the pallet passes through the door of the global warehouse (DS1). The time the pallet of filled/inspected material enters the local cold room outside of the packaging area is automatically recorded in DOC6 by an automated tagging system (RD18). The data is generated as the container passes through the door of the local cold room (DS3). The MES system calculates the time out-of-refrigeration for the pallet of filled/inspected material (CD5). The calculation is captured by the P5 processing block. The TOR data for the filled/inspected pallet is stored in a database and this information can be viewed by anyone who has access to the MES interface (STO1).

5.1.4 Packaging and Labeling Processes

The fourth process that received a future-state IP-map was the raw data generated and manipulated as filled/inspected material is removed from pallets, set into blister packaging, matched with safety and use instructions, and labeled. Figure 17 shows the future-state IP-Map generated by these processes. In order to initiate processing of filled/inspected vaccine, a worksheet associated with the packaging and labeling processes is generated in the MES by a packaging/labeling supervisor (DOC7). This worksheet electronically links the TOR data from the bulk containers and filled/inspected pallets to the TOR data of the associated packaging and labeling pallets. The first decision occurs once DOC7 is generated: the processes of packaging and labeling can either occur consecutively or intermittently. Packaged material can proceed directly to an automated labeling line or it can be returned to global warehouse and labeled at a later time once the destination country of the customer is known. Continuous processing is usually selected if a TOR alarm limit was exceeded in a previous process. Continuous process takes less time out-of-refrigeration and allows for the entire batch to remain under its overall TOR alarm limit.

Packaging and labeling occurring consecutively will be discussed first. The time the filled/inspected material is removed from the local cold room is automatically recorded in DOC7 by an automated tagging system (RD19). The data is generated as the container passes through the door of the local cold room (DS3). During the course of these processes, a disruption can occur and the filled/inspected pallet, or packaged pallet depending on the time of the disruption, can be returned to the local cold storage warehouse. These steps do not always occur and are indicated by a dashed line in the IP-map. The time the pallet of filled/inspected material, or pallet of packaged material, is returned to the local cold storage room is automatically recorded in DOC7 (RD20). When processing is ready to continue, the time the pallet of filled/inspected material, or pallet of packaged material, is removed from

local cold storage is automatically recorded in DOC7 (RD21). When labeling is complete, the time the pallet of packaged/labelled product enters the cold room is automatically recorded in DOC7 (RD22). RD20, RD21, and RD22 are recorded in DOC7 by an automated tagging system at DS2 just as material passes through the door of the local cold storage outside of the packaging area.

Figure 17: Future-State IP-Map for the Packaging and Labeling Processes

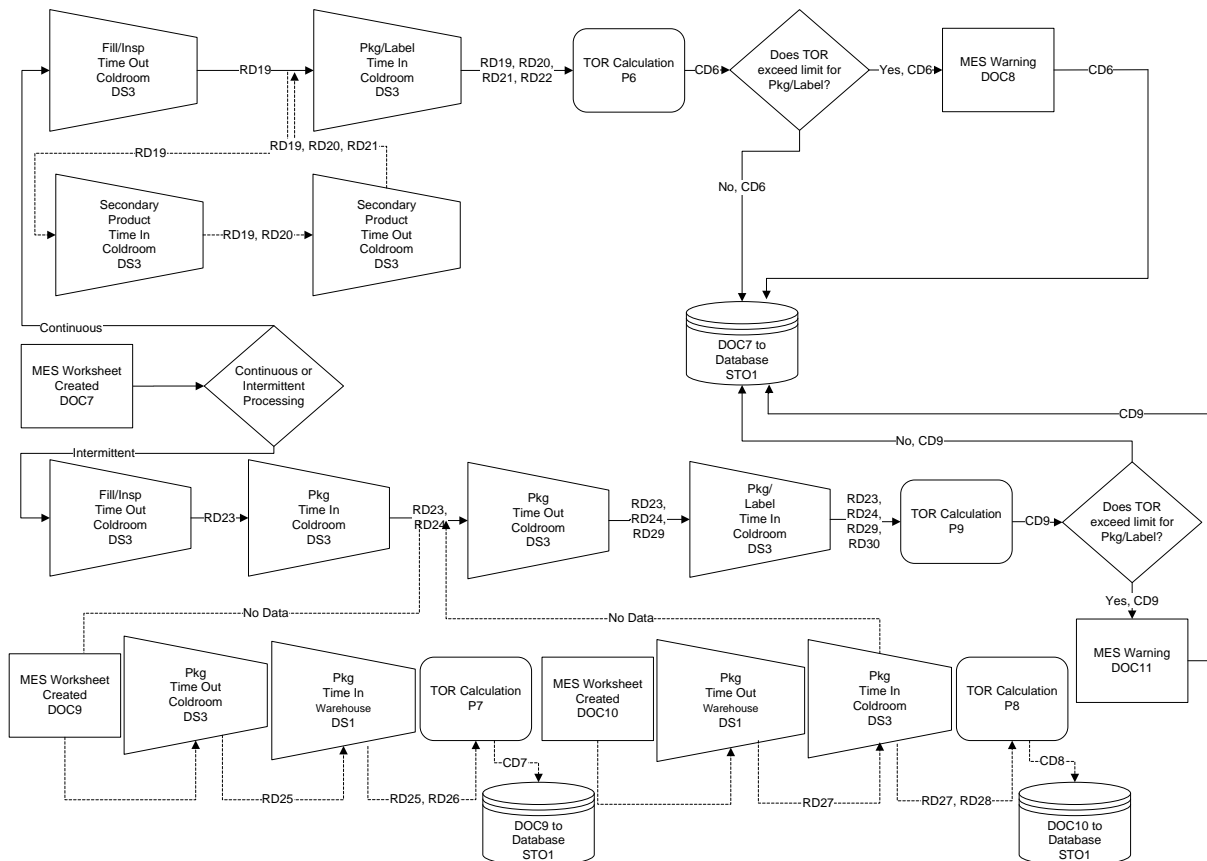

The MES uses the raw data generated in this process, RD19 through RD22, to calculate the time out-of-refrigeration for the continuous packaging and labeling processes (CD6). The calculation is captured by the P6 processing block. The TOR data for the packaging and labeling processes is reviewed against limits for these two processing steps. If the TOR limit was exceeded, a warning is generated in the MES (DOC8). Before the quality supervisor can generate a MES form to release the material to the marketplace, they must acknowledge the TOR alarm limit in the MES. Quality supervisors with access to the MES will be able to track the remaining movement of the product closely and put measures in place to prevent the lot from exceeding its overall TOR limit. If the TOR data is within the limits for packaging and labeling, no warning is generated in the MES system. The TOR data for the finished product pallet is

stored in a database and this information can be viewed by anyone who has access to the MES interface (STO1).

Filling and inspection occurring intermittently will be discussed next. The time the filled/inspected pallet is removed from the local cold room is automatically recorded in DOC7 by an automated tagging system (RD23). The data is generated as the container passes through the door of the local cold room (DS3). Once packaging is completed, the time the pallet of packaged material enters the local cold room is automatically recorded in DOC7 (RD24). RD24 is recorded by an automated tagging system at DS3 just as material passes through the door of the local cold storage outside of the packaging area. In between the packaging and labeling steps, the material can be returned to the global warehouse for long term storage prior to labeling and shipping.

In order to initiate the transfer of packaged product back to the global warehouse for long term storage, a worksheet associated with the movement of product to the global warehouse is generated in the MES by a packaging/labeling supervisor (DOC9). These steps do not always occur and are indicated by a dashed line in the IP-map. The data associated with movement of material during packaging, RD23 and RD24, remains with DOC7, the MES worksheet associated with packaging and labeling. The time the pallet of packaged material is removed from the local cold room is automatically recorded in DOC9 (RD25). The data is generated by an automated tagging system just as the pallet passes through the door of the local cold storage outside of the packaging area (DS3). The time the pallet of packaged material enters the global warehouse is automatically recorded in DOC9 (RD26). The data is generated by an automated tagging system just as the pallet passes through the door of the global warehouse (DS1). The MES uses the raw data generated in this process, RD25 and RD26, to calculate the time out-of-refrigeration for the transfer of packaged material to the warehouse (CD7). The calculation is captured by the P7 processing block. The TOR data for the packaged pallet is stored in a database and this information can be viewed by anyone who has access to the MES interface (STO1).

In order to initiate the return of packaged product from the global warehouse for labeling, a worksheet associated with the movement of product from the global warehouse is generated in the MES by a shipping/receiving supervisor (DOC10). The time the pallet of packaged material is removed from the global warehouse is automatically recorded in DOC10 (RD27). The data is generated by an automated tagging system just as the pallet passes through the door of the global warehouse (DS1). The time the pallet of packaged material enters the local cold storage is automatically recorded in DOC10 (RD28). The data is generated by an automated tagging system just as the pallet passes through the door of the local cold storage room outside the packaging area (DS3). The MES uses the raw data generated in this

process, RD27 and RD28, to calculate the time out-of-refrigeration for the transfer of packaged material from the warehouse (CD8). The calculation is captured by the P8 processing block. The TOR data for the packaged pallet is stored in a database and this information can be viewed by anyone who has access to the MES interface (STO1).

When labeling is ready to be initiated, the time the pallet of packaged material is removed from the local cold storage room is automatically recorded in DOC7 (RD29). When labeling is complete, the time the pallet of finished product enters the cold room is automatically recorded in DOC7 (RD30). Raw data points RD29 and RD30 are recorded in DOC7 by an automated tagging system at DS3 just as material passes through the door of the local cold storage outside of the filling area.

The MES uses the raw data generated in this process, RD29 and RD 30, and raw data stored during the packaging of the filled/inspected pallet, RD 23 and RD24, to calculate the time out-of-refrigeration for the intermittent packaging and labeling processes (CD9). The calculation is captured by the P9 processing block. The TOR data for the packaging and labeling processes is reviewed against limits for these two processing steps. If the TOR limit was exceeded, a warning is generated in the MES (DOC11). Before the quality supervisor can generate a MES form to release the material to the marketplace, they must acknowledge the TOR alarm limit in the MES. Quality supervisors with access to the MES will be able to track the remaining movement of the product closely and put measures in place to prevent the lot from exceeding its overall TOR limit. If the TOR data is within the limits for packaging and labeling, no warning is generated in the MES system. The TOR data for the finished product pallet is stored in a database and this information can be viewed by anyone who has access to the MES interface (STO1).

5.1.5 Transfer of Finished Product from the Packaging and Labeling Local Cold Room to the Global Warehouse

The fifth process that received a future state IP-map was the raw data generated and manipulated as finished product is transferred from the local cold storage room outside of the packaging area to the global cold storage warehouse. Figure 18 shows the future-state IP-Map generated by this process. In order to initiate movement of finished product, a worksheet associated with product transfer to the global warehouse is generated in the MES by a planner (DOC12). The time the pallet of finished product is removed from the local cold room is automatically recorded in DOC12 by an automated tagging system (RD31). The data is generated as the pallet passes through the door of the local cold room outside of the packaging area (DS3). The time the pallet of finished product enters the global warehouse is

automatically recorded in DOC12 by an automated tagging system (RD32). The data is generated as the container passes through the door of the global warehouse (DS1). The MES system calculates the time out-of-refrigeration for the pallet of finished product (CD10). The calculation is captured by the P10 processing block. The TOR data for the finished product pallet is stored in a database and this information can be viewed by anyone who has access to the MES interface (STO1).

Figure 18: Future-State IP-Map for the Transfer of Finished Product from the Packaging and Labeling Local Cold Room to the Global Warehouse

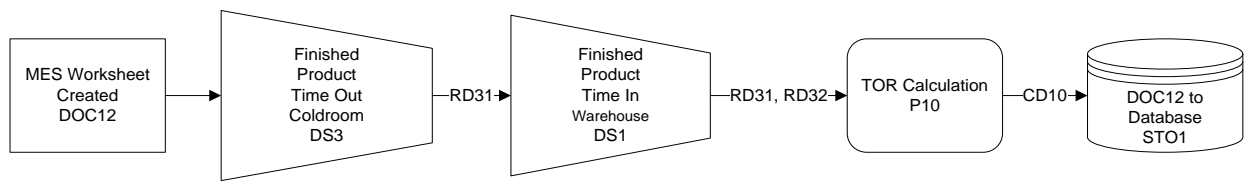

5.1.6 Finished Product Time Out-of-Refrigeration Data Review

The final process that received a future state IP-map was the quality review of TOR data for the finished vaccine product. Figure 19 shows the future-state IP-Map generated by this process. The TOR data for the vaccine product is continually updated as it moves through processing. The total time out-of-refrigeration for the material is updated after every product transfer and processing step. Anyone who has access to the MES can view the total TOR for the material at any point during processing. Once all processing steps are complete and the finished product is moved to the global warehouse for shipping, the final TOR for the finished product is calculated.

The TOR data from the transfer of the bulk material (DOC1), filling and inspection (DOC2), transfer of the filled/inspected product (DOC5 and DOC6), packaging and labeling (DOC7), transfer of the packaged material if necessary (DOC9 and DOC10), and transfer of the finished product (DOC12) is used to calculate an overall time out-of-refrigeration for the finished vaccine lot (CD11). The calculation is captured by the P11 processing block. The overall TOR for the finished product is one component of the release status for the lot of material. If the TOR for the finished lot exceeds the overall TOR limit, an investigation is initiated by the quality department (DOC13). The finished material is placed into quarantine and cannot be released to consumers until the quality investigation is completed, and the material deemed safe for release. If the TOR limit for the finished product cannot be justified through additional stability studies, the material must be discarded.

After the investigation is completed and approved by the quality department, the overall TOR data for the finished product crosses an information system boundary. The overall TOR for the finished product is transferred from paper to an electronic database (ISB1). Once the information product is complete, it is accepted by the release group (CB1). The final information product is stored in an electronic database for ease of access in the future (STO3). If the overall TOR for the finished product is within the overall TOR limit, the data directly crosses the information system boundary into the electronic database. The finished product is now one step closer to being released to consumers.

Figure 19: Future-State IP-Map for the Finished Product Time Out-of-Refrigeration Data Review

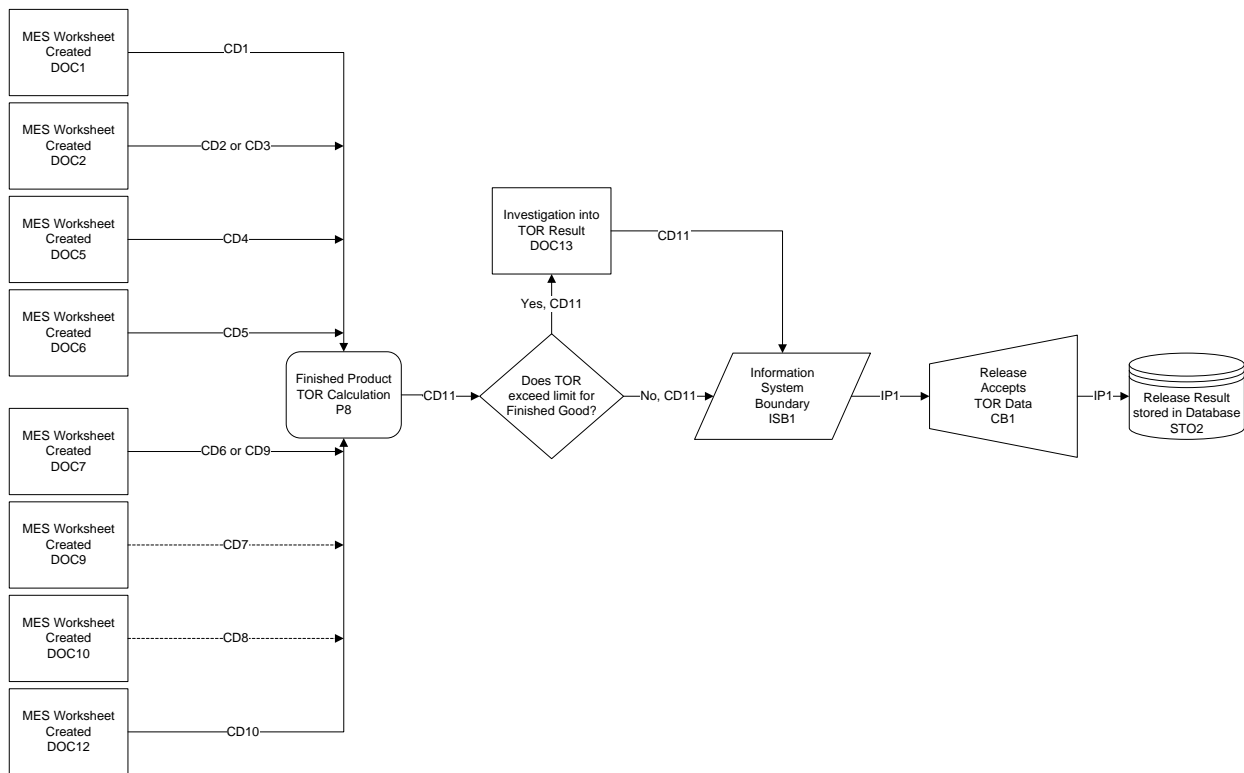

After the investigation is completed and approved by the quality department, the overall TOR data for the finished product crosses an information system boundary. The overall TOR for the finished product is transferred from the MES to an electronic database (ISB1). The customer for the final information product is the product release department. The release department awaits the final electronic version of TOR calculation, CD8, entered into the electronic database (IP1). The final information product is stored in an electronic database for ease of access in the future (STO2). If the overall TOR for the finished product is within the overall TOR limit, the data directly crosses the information system boundary into the electronic database. The finished product is now one step closer to being released to consumers.

5.2 Cold Chain Management Improvements Found in the Future State IP-Maps

The future state IP-Maps reveal a number of improvements created by the implementation of the MES. First, data points used to calculate TOR for the vaccine material are no longer transferred across organizational boundaries. Next, supervisors no longer need to be updated by supervisors from the different departments when TOR alarms occur. Finally, data is recorded and calculated automatically by the automated system. All of these improvements ensure the integrity of the data for vaccine product release.

The future state IP-Maps highlight that the number of information transfers across organizational boundaries is drastically reduced. All data points are automatically entered and stored in the MES database, completely eliminating the paper-based recording system. Documents containing critical data are no longer physically attached to pallets of material as it is transferred from one cold storage area to another. This reduces the potential for documents being misplaced or damaged on the hectic manufacturing floor. Supervisors no longer need to spend time ensuring documents containing TOR data safely arrive at their intended destination. In addition, documents are no longer attached to a pallet in the cold storage area when additional data points need to be added to the document. This practice eliminates the need to repeatedly enter cold storage to search for the necessary document.

When a TOR alarm occurs in processing, the supervisor in the area where the deviation occurred is no longer required to notify the supervisor of the next processing step about the alarm. This information is communicated via a warning in the MES. A worksheet used to gather data for the next processing step cannot be generated until the MES alarm is acknowledged by a supervisor from the downstream processing step. This ensures that the downstream supervisor is aware of the alarm and the information does not get lost in the shuffle of email. In addition, the alarm remains in place until the material is ready to be further processed. For example, if the material with a TOR alarm limit remains in a cold vault for six months before processing begins, the downstream supervisor does not need to retain that information in a localized system.

The fact that data is no longer manually entered into documents means that a manual quality check of the data does not need to occur before the product is released to consumers. The total TOR for the lot is updated continuously throughout processing. The total TOR for the finished vaccine product is calculated as soon as the material is delivered to the global warehouse. Supervisors from production, quality, or release can monitor the TOR progress and TOR alarm warnings associated with a batch from

their computer, if they have access to the MES. This means personnel from quality or release no longer have to find TOR documents in production or retention to access data. The same personnel are no longer dependent on the availability of supervisors from other departments if they want instant access to TOR data. Decisions that require immediate data checks will no longer have to wait for the required information to be gathered. Having TOR data in a central repository also makes troubleshooting easier as process engineers will be able to evaluate TOR time trends to evaluate changes in the process.

CHAPTER 6: RECOMMENDATIONS

The future-state IP maps generated in Chapter 5 have two major underlying assumptions: 1) the time at ambient temperature is measured for individual containers or pallets of material and 2) capturing time out-of-refrigeration data is an automatic process that occurs as soon as material enters or leaves cold storage. These assumptions provide the basis for two important cold chain MES implementation recommendations. First, a unit of measurement smaller than lot size must be selected for tracking material data in the MES. Second, data capture technology for material entering or leaving cold storage must be integrated with the MES.

6.1 Select a Smaller Unit of Measurement for the Cold Chain MES

Selecting a unit of measurement for product handled by the cold chain MES is a significant strategic decision. The smaller the size of the unit, the more complex the management system will have to be in order to interact with the data collection instruments. Tracking cold chain data associated with pallets of material is less involved than tracking data associated with trays of material that make up pallets or vials of material that make up trays. The unit of measurement decision for the cold chain MES is constrained by the capabilities of the instruments on the processing floor and the business planning software. If the business planning software is unable to communicate in terms of pallets of material, the unit of measurement will be fixed at lots of material. If the instruments on the floor cannot distinguish when a new tray of material has been loaded, the unit of measurement will be fixed at pallets of material.

In an ideal situation, the MES would be able to track individual vials of material from its vaccine bulk origin to its finished product container end. A more realistic recommendation is to manage material in the cold chain MES at the container/pallet level. This level eliminates the cost and complication of managing smaller units, while still providing significant benefits to the V&D division.

Vaccine material lots are separated into smaller subunits, such as trays of vials or pallets of trays, for easier handling and transportation throughout manufacturing. The time out-of-refrigeration calculated for the entire lot of vaccine during a given processing step is assigned to each of the subunits. For example, during packaging a pallet of material is removed from cold storage and setup for processing. When that first pallet of material is removed from the cold storage warehouse, the first piece of data for calculating time out-of-refrigeration is generated. Temporary packaging is removed from the pallet so that the vials can be staged, packaged, and prepared for shipping before being placed onto a new pallet. The

first pallet out of the processing unit for a given processing step is then returned to the cold storage warehouse.

During staging, packaging, or preparation for shipping, another pallet of vaccine from the lot is removed from cold storage and staged for processing. The process is repeated until a predetermined number of pallets from the lot have completed packaging. Once the last pallet from this lot has been returned to the cold storage warehouse, the last piece of data used for calculating time out-of-refrigeration for packaging is generated. These two pieces of data are then used to calculate the time out-of-refrigeration for the entire lot during this part of the manufacturing process. Individual pallets are only exposed to ambient temperature for a fraction of the time that the entire lot is exposed to ambient temperature; however, each pallet of the lot is assigned the time out-of-refrigeration of the entire lot.

If each pallet of the lot were assigned its actual time out-of-refrigeration, flexibility would increase throughout the process. Because each pallet is assigned the full time out-of-refrigeration for the lot as a conservative measure, there is an increased risk of exceeding the time out-of-refrigeration limit for that processing step. This false positive result causes a time and resource consuming investigation to be initiated. Highly trained personnel interview technicians and supervisors, review batch records, and consult with process specialists during the investigation. The investigation is reviewed by quality and release groups to ensure the product impact decisions are defensible to inquiring regulatory agencies. Personnel responsible for completing these investigations are also responsible for proactively addressing processing issues and executing process improvement projects. When a time out-of-refrigeration deviation occurs during processing, the investigation often unnecessarily diverts resources that could be utilized for process improvement projects. Because closed investigations are required for product release of the lot, investigations take precedence over process improvement projects that could have significant cost savings for the organization.

Production supervisors spend time communicating the TOR deviation to other departments and planning must revise schedules to accommodate tighter time out-of-refrigeration allowances for downstream processes. In the extreme situation in which a time out-of-refrigeration limit is exceeded for an entire lot, the material must be held in quarantine until the impact to the product from the deviation is resolved. Material implicated in an investigation must be quarantined in segregated sections of the warehouse to prevent accidental shipping. According to internal procedures, intermediate material held under quarantine cannot be processed further until the investigation is completed and the material removed from quarantine. The finished material remains in inventory occupying valuable cold storage space during the investigation. Time out-of-refrigeration alarm limit deviations can cause havoc in the

downstream schedule as material designated for processing needs to be replaced with other lots of material that have not yet reached the appropriate phase of manufacturing. Upstream lots are then pulled in the schedule requiring costly overtime and schedule adjustments.

In order to remove a lot of finished material from quarantine, it must be determined that the product has retained its chemical and biological properties. In the case where the TOR is exceeded for the entire lot and there is no stability data to support the time and temperature conditions that the lot was exposed to, a new stability study must be performed to ensure the safety and viability of the product. A real-time stability study to support an investigation is a lengthy, costly endeavor that might require reprioritization of other important stability programs. The worst-case scenario is that, in the end, the material is discarded because the overall time out-of-refrigeration for the lot cannot be justified by additional stability studies. Each lot of vaccine that is potentially discarded represents millions of dollars of lost revenue, in addition to the material not being available for patients.

In addition to the resources consumed by the investigation, the warehouse loses a great deal of capacity flexibility. If pallets of material were assigned time out-of-refrigeration based on their actual time of exposure to ambient temperature instead of conservatively assigned the TOR of the entire lot, material could be removed from refrigerated storage to create space for more critical material. Assume a lot of Meningitis vaccine accumulates a time out-of-refrigeration of 56 hours over the four major processing steps. The TOR limit for Meningitis vaccine is 60 hours. The actual time out-of-refrigeration for each pallet of Meningitis vaccine is between 12 and 18 hours. The Meningitis lot is stored in a cold temperature warehouse that is near capacity. Now assume a lot of Influenza vaccine has been manufactured and needs to be stored on-site for a short time before being shipped to the customer. If the Meningitis pallets had been assigned their actual TOR, they could be removed from cold storage for at least 42 hours before being returned to cold storage based on the TOR limit. However, since the TOR calculation for the lot only allows the material to be removed from cold storage for 4 hours, alternate accommodations need to be found for the lot of Influenza vaccine.

The lot of Influenza vaccine can be shipped to another V&D warehouse for cold storage at great expense. Alternatively, the lot of Influenza vaccine can be stored off-site, with the tradeoff being that the quality of this valuable material becomes dependent on the temperature controls of another company. Another option is that additional cold storage space can be constructed on-site for the seasonal Influenza material. Cold storage space is extremely expensive to build and maintain. Accurate TOR information for each subunit of material within a lot would allow capacity planners to more accurately forecast their needs.

6.2 Ensure Cold Chain Data is Captured Automatically

Capturing the time that vaccine material is removed from and returned to cold storage is the critical set of data points for calculating time out-of-refrigeration. A strategic improvement to the current paper-based data collection system would be an automated data collection system. In the same manner that MES integrate with process instruments to capture critical process data such as weights, temperatures, and pressures, the MES can integrate with instruments that record time.

My recommendation would be for each container or pallet of material to be associated with a unique radio frequency identification (RFID) tag that is understood by the business planning software and the MES. RFID tag readers would be placed at the entrance of every cold storage location. Each time vaccine material with an RFID tag passed through a cold storage location, the RFID tags would generate a data point. The incoming data supplied by the RFID tag readers would be associated with vaccine product through MES worksheets. The summation of data from these worksheets would allow the MES to maintain an updated time out-of-refrigeration for all vaccine material.

The MES are already responsible for selecting which containers or pallets of material will be used for the next processing step. These associations will allow TOR data from previous processes to be included in the current material TOR calculation. If pallets of material are blended in manufacturing to form the next material, logic can be written in the MES to assign the new material the worst-case time out-of-refrigeration from the starting pallets. If a lot of material is split into multiple upstream lots, the MES will understand these associations and will be able to calculate the TOR for the new material based on the data from the input material.

An alternative solution to my recommendation would be to have bar codes on each container or pallet of material instead of RFID tags. RFID tags are beneficial because the data is automatically recorded by the RFID tag reader. Bar codes must be scanned to generate data. While the bar code generated data would automatically be linked with the appropriate material in the MES, this solution would require additional manpower and resources. Technicians responsible for collecting the TOR data would have to be trained on how to scan the bar codes each time material is removed from or added to cold storage. In addition, the technician would have to scan the bar code in a timely manner to ensure the integrity of the data. Automated data collection for the cold chain MES has a number of other efficiency benefits for the V&D division.

With automated collection of time out-of-refrigeration data, analysis of the data could be performed and metrics established. The time out-of-refrigeration alarm limits for each of the four major

processing steps are determined arbitrarily based on historical processing times. Additionally, each of the time out-of-refrigeration alarm limits has some buffer time incorporated in the limit for unanticipated process interruptions. The anticipated time that material will be exposed to ambient temperature is less than the alarm limit for the associated processing step. If the time out-of-refrigeration alarm limit is exceeded upstream, this often does not impact the finished product that is shipped to the customer because downstream processing steps can often be executed in a shorter period of time. However, a process deviation investigation is still initiated.

While it is possible to expose product to ambient temperature for shorter periods of time during downstream steps, this activity also requires additional management and resources. Lots that need a short time out-of-refrigeration require additional operators to ensure the tighter time out-of-refrigeration limit is met. The additional operators are often required to be compensated at overtime pay. The planner also manages the extra stress of readjusting the processing schedule against current product needs. This becomes exceedingly difficult during times of high production in the processing calendar. Moving operations to a slot in the production schedule where it has a better chance of meeting the shorter time out-of-refrigeration specification can lead to sacrifices in meeting market demand for other products.

The time out-of-refrigeration alarms for each processing step do serve as a guide for how long each processing step should last. Automated data collection would allow for accurate time out-of-refrigeration alarm limits to be generated for each processing step. This information could also be used as an effective metric for process evaluation and to proactively address problems. Collecting and analyzing this data could implicate a particular department in the process sequence that is routinely impacting downstream processing steps by exceeding their allotted TOR. Sharing this data with all departments could make members of the production team that are not meeting expectation appreciate the direct impact on their colleagues. Sharing this data could also create competition that might incentivize departments to perform more efficiently.

BIBLIOGRAPHY

- Allan, I. (2009). *Global Automation Strategy Vaccines & Diagnostics*. Automation & MES. Internal Document.
- Bishara, R. H. (2006, January/February). Cold Chain Management - An Essential Component of the Global Pharmaceutical Supply Chain. *American Pharmaceutical Review* , 1-4.
- Blumenthal, R. (2004). Manufacturing Execution Systems to Optimize the Pharmaceutical Supply Chain. *Pharmaceutical Industry* , 66 (11a), 1414-1424.
- FDA. (2010). *Guidance for Industry: Current Good Manufacturing Practice in Manufacturing, Packaging, Labeling, or Holding Operations for Dietary Supplements; Small Entity Compliance Guide*. Rockville, Maryland, United States: Food and Drug Administration.
- ICH. (2003). *Guidance for Industry: Q1A(R2) Stability Testing of New Drug Substances and Products*. Rockville, MD, United States: Food and Drug Administration.
- ICH. (2010). *The Value and Benefits of ICH to Drug Regulatory Authorities - Advancing Harmonization for Better Health*. Geneva, Switzerland: International Conference on Harmonization of Technical Requirements for Registration of Pharmaceuticals for Human Use.
- Lee, Y. W., Pipino, L. L., Funk, J. D., & Wang, R. Y. (2006). *Journey to Data Quality*. Cambridge, Massachusetts, United States: The MIT Press.
- Novartis. (2010). *Novartis Group Annual Report 2010*. Basel, Switzerland: Novartis International AG.
- Rother, M., & Shook, J. (2003). *Learning to See: value-stream mapping to create value and eliminate muda*. Brookline, Massachusetts, United States: The Lean Enterprise Institute, Inc.
- World Health Organization. (2005). *Good Distribution Practices (GDP) for Pharmaceutical Products: QAS/04.068/Rev.2*. Geneva, Switzerland: WHO Press.