

# ORCA-II: An Improved Autonomous Underwater Vehicle



*Robert C. Altshuler, Henry H. Atkins, Alexis A. Cavic, Corrina C. Chase,  
Roger S. Cortesi, Benjamin M. Davis, Francisco J. Delatorre, Jonah D. Elgart,  
Holly G. Gates, Matthew D. Hancher, Andrew S. Huang, Linda A. Kiley, Ara N. Knaian,  
Jacky Mallett, Casey R. Muller, Seth O. Newburg, Benjamin F. Polito,  
Matthew S. Reynolds, Eric D. Smith, Emily C. Warmann*

Massachusetts Institute of Technology  
Project ORCA c/o Ara Knaian  
20 Ames Street Room E15-410, Cambridge, MA 02139

## **Abstract**

We have designed and are building the ORCA-2, a fully autonomous submarine, to enter in the Second Annual International Autonomous Underwater Vehicle competition. The ORCA-2 is a fully redesigned version of our vehicle for the first competition, the ORCA-1.

ORCA-2 is designed for efficient, high-speed, reliable operation in shallow water. It is 60" long, 32" wide, and has a mass of 50 kg. It has a hydrodynamic design and modular construction. Side-mounted thrusters are used to drive and differentially turn, and vertically mounted thrusters are used to dive and pitch, and hold the vehicle at depth. The vehicle is powered by a 420 watt-hour sealed lead-acid gel-cell battery, has a top speed of 1.8 m/s, and can operate for 2 hours on a single charge.

ORCA-2 images its surroundings using a 1.2 MHz scanning sonar system and a set of five bottom-facing 1 MHz echo sounders. It has a comprehensive suite of navigational sensors, including a magnetic compass, a water pressure depth sensor, a fluid inclinometer, and a 6-degree of freedom inertial measurement unit. It navigates using a map-matching algorithm, comparing information gathered with the sensors to a mathematically generated map of the arena.

An onboard Pentium-based computer running Linux controls ORCA-2. For development, the vehicle can be monitored from multiple on-shore computers, using a spread-spectrum radio data link. The vehicle can be driven with a control stick, the control program can be changed, and all variables can be displayed and modified using a graphical user interface.

## **Introduction**

The International Autonomous Underwater Vehicle Competition poses an engineering challenge which our team, composed entirely of students, intends to meet. The contest arena is the P-253 test pond at the Naval Coastal Systems Station in Panama City, Florida. The pond is oval in shape, 110 m by 70 m, and has a maximum depth of 12 m at the center. Six gates, with two uprights and a crossbar made of PVC pipe, will be submerged along the perimeter of the pond, along the 3 m isobath. Beyond the sixth gate, a submerged pipeline starts on the 3 m isobath and leads to the target zone, a 3 m by 3 m underwater platform. Each team's fully autonomous underwater vehicle must pass between the uprights and under the crossbar of each gate, enter the target zone, release a depth marker inside the target zone, and surface. The vehicle is not permitted to drop navigation beacons or utilize the Global Positioning System. Points are awarded for each gate traversed, for marking the target zone, and for time.

Our vehicle, the ORCA-2, is designed to complete the course reliably, repeatedly, and efficiently, under a wide variety of interfering conditions and irregularities in the course layout.

The ORCA-2 (Figure 1) is a completely redesigned version of the ORCA-1

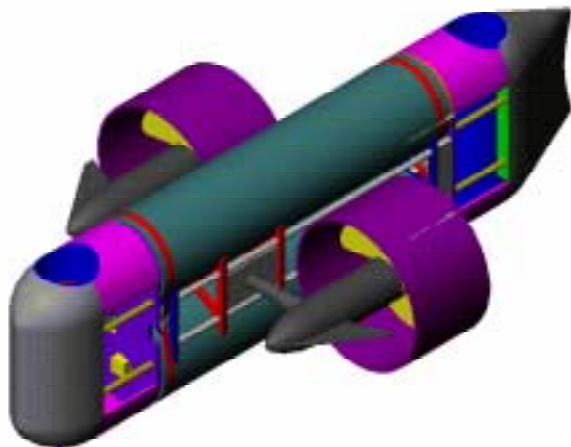

*Figure 1: The ORCA-2*

(Figure 2), our team's first place entrant in the 1998 AUVSI AUV Competition. We are incorporating the strongest parts of the ORCA-1 into the ORCA-2, while correcting design flaws and completely replacing systems that were unreliable or simply did not work.

Every component of ORCA-2 that we did not build ourselves can be ordered and delivered within a few days, which has allowed a short design cycle and a relatively low budget. In addition, the design was made as modular as possible, to facilitate the replacement of failed components and the introduction new systems.

## **Design Overview**

The hull of the ORCA-2 is designed to be a modular, flexible, easy-to-use platform for an electronic payload. The main hull has two dry compartments that house the batteries and electronic systems. It also has two open compartments that flood with water where the sonar transducers and depth marker are mounted.

The vehicle is positively buoyant by approximately 2%, and is held at depth by two thrusters mounted in vertical ducts in streamlined modules mounted at the bow and stern of the hull. The two main thrusters are mounted on either side of the vehicle, allowing differential turns.

The vehicle is controlled by an on-

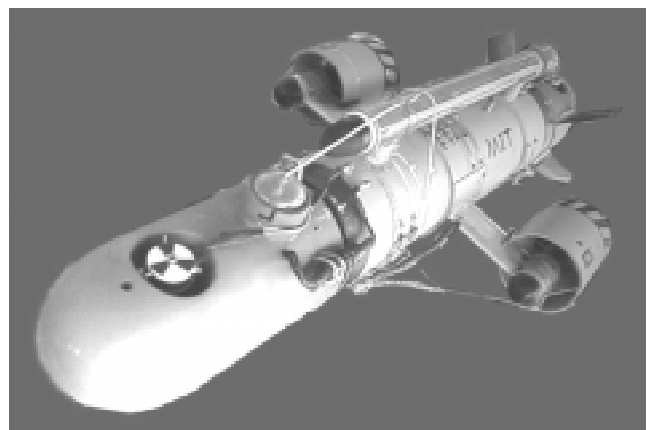

*Figure 2: The ORCA-1*

board computer running the Linux operating system. A spread-spectrum radio data link allows the sub to be controlled from on-shore laptops for testing purposes. The operators can observe all sensor readings and internal state with a graphical user interface. The control program can also be run in simulator mode, using a mathematical model of the pond to generate simulated noisy sensor data, so that control code can be debugged on land before it is tested in the water.

The ORCA-2 navigates by collecting information with a comprehensive suite of sensors, and comparing it to a mathematically generated map of the arena. A three-axis Doppler sonar system, magnetic compass, fluid-filled inclinometer, and a 6-degree-of-freedom inertial measurement unit are used to establish the heading, attitude, and velocity of the vehicle. The vehicle also has five sonar echo sounders, pointed in different directions, to measure the distance to the sloping bottom. The computer searches the map, and finds the maximum-likelihood three-dimensional location for the vehicle, based on the results of the distance, velocity, and orientation measurements over time. The vehicle uses its navigation system to follow a pre-programmed path around the three-meter isobath, curving in-

ward at the two corners in the arena to avoid running aground.

To insure that it passes through all of the gates, the ORCA-2 is equipped with a mechanically scanning sonar system. As the vehicle circumnavigates the pond, it searches for gates. When it locates a gate, it corrects its course, if necessary, to insure that it goes through the center.

After it goes through the sixth gate, the vehicle follows a serpentine path along the 3 m isobath. The pipeline is detected as a sharp and momentary decrease in the forward-facing echo-sounder range. Once the pipeline is detected, the navigation system is disabled, and the vehicle controls its heading to keep the pipeline at the center of its oscillating course. When the vehicle reaches the target zone, it deploys the depth marker and surfaces.

### Mechanical and Electrical Systems

The hull of the ORCA-2 has twin dry compartments that contain the electronic systems. The compartments are made of six-inch PVC pipe, and are 27 inches long. The tubes are mounted on an aluminum frame (Figure 4), one above the other. A gasketed aluminum plate is bolted to the stern end of each pipe.

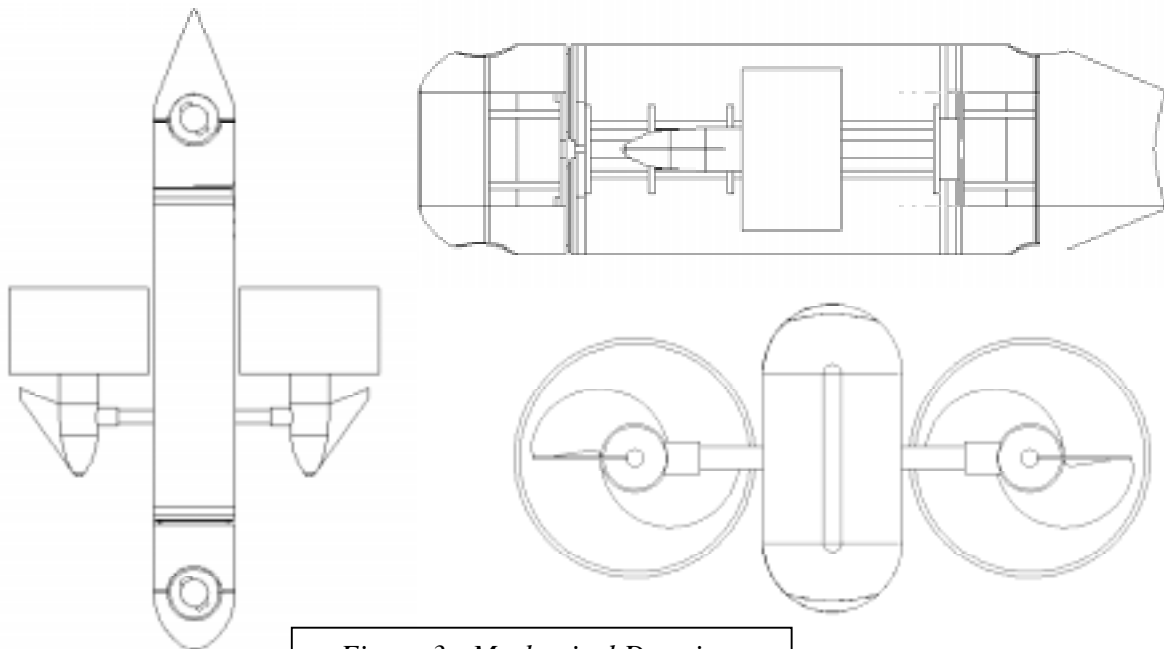

Figure 3 - Mechanical Drawings

All through-hull electrical connections are made with bulkhead connectors mounted in these plates. The bow end of each pipe is sealed using commercially available test plugs, providing easy access to the dry compartments. The top compartment holds the computer, compass, inertial sensors, and sonar processing electronics. The bottom compartment contains the batteries and power electronics. This arrangement was chosen to make the location of the batteries as low as possible, to lower the metacentric height and increase the righting moment of the vehicle. Tests have confirmed that the ORCA-2 is very stable in pitch and roll.

Streamlined flooded modules (Figure 5) are mounted at the bow and stern of the vehicle. These modules attach to the aluminum frame with hinges, and swing away with a clip, to allow access to the electronics compartments and connector panels. Each module contains a vertical thruster duct and a flooded compartment. The flooded compartments hold the scanning sonar head, the downward-facing sonar transducers, the marker drop mechanism, and the competition supplied tracking beacon.

Each dry electronics compartment holds a slide-out aluminum card, on which all of the electronics are mounted. The card connects to the compartment's aluminum end plate with a blind-mating multi-pin connector,

so that it can be removed without disconnecting any cables.

The ORCA-1 had to be partially disassembled to access the internal electronics, a process that involved the removal of several screws and over ten connectors. The ORCA-2 can be opened in less than 15 seconds with a single wrench (to open the commercial test plug), and the electronics can be removed, and serviced without disconnecting any cables.

### **Bow and Stern Hull Modules**

The bow and stern hull modules (Figure 5) consist of an aluminum frame, a vertical thruster duct, and a streamlined fairing. The fairings are made from ABS plastic thermoformed onto hand-shaped wooden molds. The stern hull module has four stabilizing fins mounted at forty-five degrees to the vertical. The aluminum frame of each hull module provides ample mounting points for a large amount of outboard equipment.

### **Vertical Thrusters**

The vertical thrusters are shrouded by 4-inch PVC ducts mounted inside the bow and stern hull modules. The thrusters are made from sealed motors removed from Rule 1100 bilge pumps and 2.75 inch RC boat propellers. Each thruster has a fairing made from PVC, to streamline the flow of water through the duct.

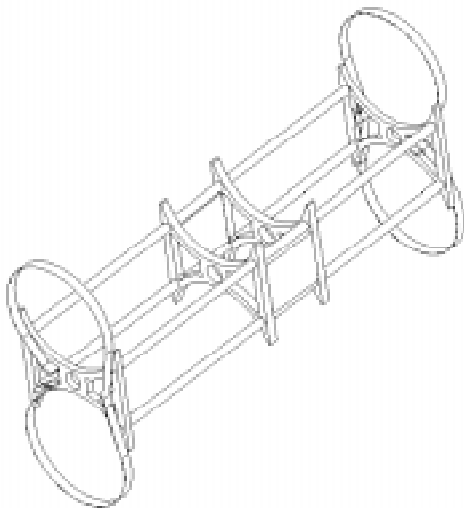

*Figure 4 - Aluminum Chassis*

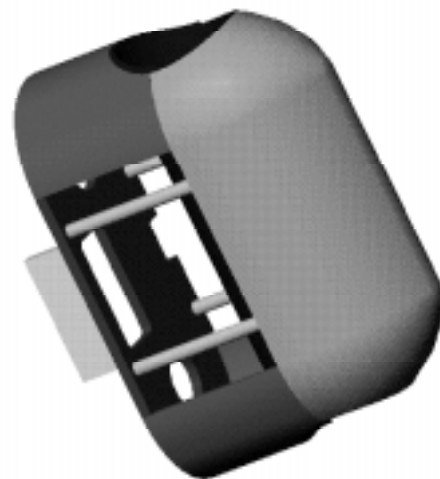

*Figure 5 - Forward Hull Module*

## **Main Thrusters**

The main thrusters are Minn-Kota reversible electric outboard motors with 10" propellers. We chose these motors for their high power, reasonable cost, rugged design, and double O-ring seal. Each motor draws 15A at 12V, and generates 30 pounds of thrust. The motors are mounted to the aluminum frame on an adjustable carriage so that they can be positioned to maximize performance. An 11-inch aluminum shroud is clamped around each thruster for safety.

## **Motor Control**

All four of the thrusters can be run at 32 discrete speeds in both directions. To drive the motors, we use four Novak "Super Rooster" FET H-bridge PWM speed controllers, designed for radio-controlled cars. Despite their low cost (\$100), these units outperformed many OEM motor drivers that we evaluated. The units can switch over 40A at 12V, have an on-resistance of less than .002 ohms, present a simple and reliable control interface, and have short-circuit protection and thermal shutdown. An SH1 embedded controller takes commands from the computer over an RS-232 port, and generates the servo signals needed to operate the speed controllers. The servo signals connect to the motor drivers through 74OL6010 optoisolators to prevent the coupling of electrical noise from the motors.

## **Electrical Connections and Pressurization**

Electrical connections through the hull are made with hermetically sealed locking multipin connectors made by W. W. Fisher. The connectors cost about \$30 each, and are rated to 250 feet of water. Each outboard component connects to the vehicle using its own connector mounted in the aluminum plugs at the stern end of each electronics compartment. In addition to the outboard component connectors, there is a jumper cable connecting the two electronics compartments and a tether connector for development and

testing. To reduce the risk of water entering the hull, and aid in leak detection, the electronics compartments are pressurized to 10 PSIG during operation. Through-hull electrical connections on the ORCA-1 were made by passing insulated wires through modified Swage-Lok fittings mounted in the hull. This method made it difficult to remove external components once installed. The waterproof connectors allow rapid assembly and disassembly of the vehicle, which facilitates maintenance and design changes.

## **Target Zone Marker**

The marker drop mechanism is bolted to an aluminum plate in the bow flooded compartment. The marker drop mechanism is located in the bow with the sonar so the computer can select the drop location without taking in account the orientation of the vehicle. The 24V, 2.5A pulse required to drop the marker is switched by a solid-state relay attached to the motor controller.

## **Electronics Cards**

All electronics are mounted on slide-out aluminum cards for bench-top servicing. The power electronics, fuse box, and marker drop electronics are mounted on one six inch wide, 24 inch long reinforced aluminum sheet. The batteries are mounted on an identical aluminum sheet that bolts to its underside, forming a single card. This card slides into PVC rails attached to the insides of the bottom electronics compartment. This arrangement allows the batteries to be easily replaced, to extend testing time. All electrical connections from the card to the compartment's stern connection plate are made through a mating pair of ELCON "75A Middle Drawer" backplane connectors, which mate automatically when the card is pushed into the compartment.

In the top compartment, the computer and sensing electronics are mounted on a similar card. The top card has a hole pattern drilled into it, to facilitate addition and rearrangement of components. Electrical connections from the top card are made with a mating

pair of ELCON "Lower Drawer" backplane connectors.

## **Power Supply**

The vehicle uses a bank of three 7.2 AH 12V sealed lead-acid gel-cell batteries to power the thrusters, and a fourth to power the electronics. A Lambda PM3012to512 switching converter provides 5V at 5A for the computer, and +/-12V at 1A for analog circuitry. Each battery bank, power supply voltage, and motor has its own fuse in an ATO/ATC automotive fuse box.

Power from the batteries is switched through a set of Siemens VF4-81F11 40A mechanical relays. Two waterproof mechanical switches with colored rip cords can be used to power down the motors or the entire vehicle.

## **Monitoring System**

The temperature and pressure in each electronics compartment are measured using an LM35 temperature sensor and an ASCX30AN 30PSIA pressure transducer. The motor and electronics battery currents are measured using two LEM LV25-P Hall Effect Current Sensors. The motor and electronics battery voltages are measured using two LA55-P galvanically isolated voltage sensors. Sensors mounted in the bottom compartment connect to spare A/D inputs on the motor controller microprocessor. Sensors mounted in the top electronics compartment connect to spare A/D inputs on the PC/104 stack.

These sensors allow us to detect electrical failures, low-battery conditions, and leaks before they render the vehicle inoperable.

## **Imaging**

The competition presents several imaging tasks: Determining the location of gate uprights, identifying and following the pipeline to the target zone, and avoiding underwater obstacles, including competition officials.

We chose to use sonar rather than optics for a variety of reasons. First, all of these

tasks require range information and while sonar images inherently contain this information, it is difficult to extract from optical images. In addition, sonar can perform in murky water and under unknown lighting conditions and can detect targets of any color or surface texture. By contrast, accurate computer interpretation of optical images requires precise knowledge of lighting conditions and target characteristics. Observation of the test pond's turbidity and white liner also raised serious concerns that optical imaging would suffer from lack of contrast between target objects and the background. Finally, a sonar transducer is much more physically robust than a glass camera lens and most are specifically designed to operate in water, often under conditions far more demanding than those of the test pond.

## **Sonar Imaging System**

The ORCA-2 uses a Tritech ST1000 sonar system to image the gate uprights and locate obstacles. The ST1000 is a 1.2 MHz echo sounder that can be mechanically scanned over a 360-degree arc. It is mounted vertically, and scanned over 180 degrees as the vehicle travels, to produce a continuously updated map of objects in the horizontal plane of the vehicle. The ST1000 transmits images over an RS-232 port to the computer for interpretation.

The computer translates and rotates each scan line of the image to account for the motion of the vehicle while scanning, to assemble a plot in real time of the area surrounding the vehicle. The computer searches for gates by searching for pairs of reflections that are 3 m apart, that are approximately on the 3 m isobath, and that occur on a line roughly perpendicular to the side of the pond. When the imaging program identifies a valid gate, it overrides the navigation program, and adjusts the vehicle's heading so that it drives through the center of the gate. If the imaging program detects a large number of valid gates in a single image, due to water-borne scatters

or other interference, it disables itself to avoid erroneously steering the vehicle.

The ORCA-1 did not have any means for locating gates, and its navigation system occasionally steered it a few feet to the left or right of a gate. This gate-imaging subsystem should eliminate this problem on the ORCA-2, enabling the vehicle to pass through all of the gates, even with navigation errors on the order of 5-10 m.

### **Pipeline Imaging**

The ORCA-2's downward-facing echo sounders have a beam-width of 5.8 degrees. At a range of 1 m, this corresponds to a main lobe width of 10cm, which is approximately the width of the pipeline. To follow the pipeline, the vehicle will take a serpentine path along the three-meter isobath after it passes the sixth gate. When the pipeline begins, it should be clearly detectable by the front echo sounder as a sharp, momentary decrease in depth. The vehicle will dynamically adjust its heading and depth to follow the pipeline at an altitude of 1 m.

### **Navigation**

The ORCA-2 has a comprehensive array of navigational sensors that allow it to determine its speed, heading, attitude, and position throughout the mission. A water pressure sensor is used to measure depth, a magnetic compass is used to measure heading, and a fluid-filled inclinometer is used to measure attitude. To complement these sensors, we use a six degree-of-freedom strap-down inertial measurement unit to measure the vehicle's rate of turn and acceleration.

Five range/Doppler echo sounders, mounted at the bow of the vehicle, are used to measure the vehicle's velocity and the distance to the bottom at various angles. The ranges from these sounders, combined with a short-term dead-reckoning estimate of the vehicle's motion, are used to implement a map-matching algorithm to determine the vehicle's position.

The ORCA-1 followed the three-meter isobath using a depth sensor and PID control. Although this strategy was effective, it was very inflexible. In particular, when we discovered that following the 3 m isobath caused the vehicle to run aground at the pond's elliptical corners, we were not able to modify the vehicle's path in order to avoid them but still follow the isobath elsewhere. The ORCA-2's navigation system is completely de-coupled from its programmed path, making such a modification much simpler to implement.

### **A) Algorithms**

#### **1) Heading, and Attitude**

We implement a simplified Kalman filter to process data from the compass, inclinometer, gyroscopes, and accelerometers into a maximum-likelihood estimate of the vehicle's orientation. The simplified Kalman filter is derived by making the assumption that the expected error will remain relatively constant in time. This simplification reduces the computation required by over 50% without substantially reducing the effectiveness of the filter. The output of the modified Kalman filter is a highly accurate estimate of the heading and attitude of the vehicle.

#### **2) Velocity**

Four of the range/Doppler echo sounders are mounted in a Janus configuration, and are used to resolve the X, Y and Z components of the bottom velocity. The bottom-velocity vector is rotated by the vehicle's heading and attitude to calculate the vehicle's velocity vector.

#### **2) Absolute Positioning**

The vehicle determines its absolute position using a map-matching algorithm. The arena is divided into grid squares, each 25 cm on a side. A map of the arena (which comprises about 100,000 grid squares) is generated by modeling the arena as an ellipsoid depression with a truncated bottom. As the vehicle travels along its course, it uses the

range/Doppler echo sounders to measure the distance to the bottom at various angles. This information is used over a sliding window to produce five estimated bottom tracks. The computer integrates the vehicle's calculated velocity vector to produce a crude dead-reckoning estimate of the vehicle's path over the sliding window. This path is used to translate and rotate the five range measurements to form the estimated bottom tracks for the interval.

To make a position estimate, the computer searches the map of the pond, to find the maximum-likelihood location for the vehicle, given the estimated bottom tracks.

## **B) Sensors**

### **1) Inertial Measurement Unit**

The inertial sensor package consists of two inexpensive (\$150) Gyration MG100 two-axis piezoelectric tuning-fork rate gyroscopes, and three inexpensive (\$20) ADXL50 silicon micromachined accelerometers. These rate gyros have a resolution of 0.1 degrees/sec, a full-scale range of 150 degrees/sec, and a bandwidth of 10 Hz. The accelerometers have a resolution of 5 milli-g, a full-scale range of 5 g, and a bandwidth of 6 kHz. Both of these sensors provide analog outputs for which we have designed a custom acquisition and filtering system.

Each sensor's output is appropriately filtered and amplified by laser-trimmed instrumentation amplifiers and the signals are scaled to the proper 0-5V range for the A/D converter. A set of multiplexers selects which of the 10 desired voltages is to be converted. This voltage is then sampled and digitized by a 100Ksps 16-bit A/D converter. A PIC16C76 microcontroller manages the A/D converter and the multiplexers. It keeps a running 10-pole FIR filter on each value, and queues the values for output on demand to the main computer. The IMU is connected to the main computer using an RS-232 serial port.

### **2) Depth Sensor**

To measure depth, we use a Sensotec TJE series pressure sensor. It has a full-scale range of 50 PSIA, and temperature-compensated accuracy of  $\pm 0.12\%$ , producing a depth measurement accurate to  $\pm 1.3$  cm. The voltage output of the pressure sensor is connected to a Diamond Systems MM-16 A/D converter card in the PC/104 stack.

The pressure sensor used on the ORCA-1 had a millivolt level output, which made it very susceptible to radio-frequency interference from the 1 W radio transmitter, and often caused erroneous depth readings. The pressure sensor used on the ORCA-2 has a 0-5V output, which is over 1000 times less susceptible to this type of interference.

### **3) Compass Module**

The ORCA-2 is equipped with a TCM2-50 magnetic compass from Precision Navigation. It has a magneto-inductive three-axis magnetometer, a fluid-filled inclinometer, and a microprocessor that filters out hard-iron distortion and alerts the computer to soft-iron distortion.

### **4) Navigation Echo Sounders**

#### **Overview**

Accurate positioning using a map-matching algorithm requires an accurate measurement of the vehicle's speed, and accurate measurements of local terrain geometry. We researched commercial Doppler speed logs and range finders, and discovered that assembling a suitable system from commercial sonar systems would cost well over \$30,000, far more than we could afford. Therefore, we decided to build our own Doppler sonar system.

The ORCA-2 has five downward-facing sonar transducers, mounted on a dome under the forward hull module. The transducers (Reson TC3027, \$360) have a center frequency of 1 MHz, a conical beam pattern, and a 5.8 degree beam width. Four are mounted in



a Janus configuration (30 degrees from the vertical in a square array), and one faces straight down. All five transducers are run as individual active echo sounders by a custom-designed control unit, and are used to measure the range and speed of the bottom. This allows the vehicle to determine its altitude, the distance to the bottom at several angles, and the three-axis bottom velocity.

### **Signal Design**

Each echo sounder pings at 25 Hz, which results in a maximum unambiguous range of 30 m. Each sounder alternates between two types of pings, one for accurate range measurements, and one for accurate Doppler measurements. The range ping is a 100 $\mu$ s long 1 MHz burst, binary phase modulated with a 10-bit Barker code, allowing a range resolution (determined by the bit size) of  $\pm 0.75$  cm, and a minimum range (determined by the code length) of 7.5 cm. The Doppler ping is an 800  $\mu$ s CW pulse, which results in a phase change of 192 degrees / meter / second over a single pulse, and requires a minimum range of 60 cm.

### **Signal Chain**

An Analog Devices AD7008 direct digital modulator IC is used to generate the pings, which are amplified by an Apex PA09 power op amp, passed through a diode transmit/receive switch, and projected into the water.

Analog processing of the received signal is centered around an Analog Devices AD607 "monociever" IC, which contains a doubly-balanced mixer, a 100dB voltage-controlled amplifier, and a quadrature demodulator. In receive mode, the AD7008 is used as a 9.7 MHz local oscillator. The received echo signal, nominally 1 MHz, is mixed with the 9.7 MHz local oscillator. This IF signal is passed through a 10.7 MHz bandpass filter, amplified by the variable gain amplifier, passed through another 10.7 MHz bandpass filter, and input to the quadrature demodulator, where the signal is de-modulated

to baseband using a 10.7 MHz square-wave oscillator. Thus, the outputs of the quadrature demodulator are the complex envelope of the received signal.

The complex envelope is sampled at 500 kHz by an Analog Devices 10-bit matched quadrature A/D converter for digital processing.

### **Digital Signal Processing and Control**

Each echo sounder is controlled by an SH1 embedded controller. It generates the control signals for the AD7008 and AD9201, generating the pings and buffering samples of the return signal.

For range pings, the system cross-correlates the magnitude and phase of the return signal with the code used to form the pings. The lag to the first large cross-correlation peak is used to compute the range to the target. For Doppler pings, the system identifies the first large-magnitude ping of the proper length and performs spectral analysis to determine the Doppler frequency. After each pair of pings, the unit computes the range and speed of the bottom, converts them to engineering units, and sends them to the computer over an RS-232 port.

### **Mission Strategy**

When the ORCA-2 is released from the dock, it dives to 1 m and executes a pre-programmed series of turns, to allow the map-matching navigation system to acquire an initial position fix. Once a fix is acquired, it turns to the right and follows a path around the 3 m isobath, curving inward to avoid the pond's elliptical corners.

When the vehicle detects a valid gate using its scanning sonar system, it adjusts its course to go through it. Once it has gone through six gates, it finds the pipeline, follows it, releases the target zone marker, and surfaces.

## **Control Computer**

All navigation and control code is implemented on a Pentium-based PC/104 embedded computer, running the Linux operating system. We chose this computing platform for its familiar and flexible programming environment, remote operability, and the availability of modular, standard peripherals.

### **Development**

For development and testing purposes, the computer uses a multicast UDP protocol to communicate with multiple on-shore computers.

From each station, the vehicle can be remotely controlled with a stick, and all variables and sensor values can be inspected and modified with a graphical user interface. In addition, the main control program can be modified and re-compiled. All of this can be done while the submarine is submerged and operational.

The control program has a simulation mode, which uses a simple mathematical model of the pond and the vehicle to generate simulated noisy sensor data in response to motor commands. The simulation mode allows control code to be developed and debugged in the lab before it is tested in the water.

### **Tether and Data Link**

The wireless data link is a pair of Freewave DGVRO-19 frequency-hopping spread spectrum data transceivers. These devices operate over the 138-144 MHz frequency band, transmitting at 2 W. They connect to the host computer using an RS-232 serial port, and have a maximum data rate of 115 kbps/sec. In air, they have a 20-mile line-of-sight range, but with one unit underwater, depth becomes the limiting factor. In a chlorinated swimming pool, the units perform well up to a depth of about 2 meters. Communication with the vehicle can also be established using an Ethernet tether.

## **Conclusion**

The ORCA-2 is a completely redesigned and rebuilt version of the ORCA-1. We examined every system, reusing systems that worked well, and redesigning systems that did not. As of the writing of this paper, the hardware platform has been nearly completed, and much of the software has been written. We have tested the vehicle under joystick control, and tested the sensors in the pool. Development is proceeding well, and we look forward to competing with the vehicle in Florida.

## **Acknowledgements**

Thanks to Doreen Morris from the Provost's Office, who found us space and taught us how to raise funds. Thanks to our sponsors; the Center for Global Change Science; the Department of Earth, Atmospheric, and Planetary Science; the Media Lab; the Department of Ocean Engineering; the Precision Engineering Group; and the Sea Grant Program. been continuing friends of our team on the Faculty. We extend our sincerest thanks to everyone who went above and beyond the call of duty to help us, including The Alumni Pool lifeguards, Prof. A. Douglas Carmichael, Ronn Crichlow, Katie O' Dair, Prof. Neil Gershenfeld, Jim Harrington, Prof. Joseph Jacobson, Edmund Jones, Prof. John Leonard, Prof. Andrew Lippman, Armen and Ann DerMarderosian, Prof. Joseph Paradiso, Prof. Ronald Prinn, Sharon Trohon, Prof. Alex Slocum, the residents of pika, Prof. Kim Vandiver, and Scott Willcox.