

ORCA-VI: An Autonomous Underwater Vehicle



Robert C. Altshuler, Joshua F. Apgar, Alfred C. Ashford, Michael J. Broxton, Jonathan S. Edelson, Christopher J. Khan, Alex Khripin, Ara N. Knaian, Adam D. Kraft, Steven D. Lovell, Karl-Magnus W. Mclechie, Leonard A. Mazzone, Seth O. Newburg, Katherine L. Rorschach, Joseph C. Stark, Debra E. Horng, Kawika A. Uechi

Massachusetts Institute of Technology
Project ORCA
77 Massachusetts Avenue, Room 4-405
Cambridge, MA 02139

<http://web.mit.edu/orca/www>

The ORCA-VI is a fully autonomous submarine built to compete in the 2003 International AUV competition. The ORCA-VI is 48" long, 28" wide, and approximately 37 kg. The vehicle is propelled by a pair of horizontal thrusters mounted on the sides and a pair of vertical thrusters on the bow and stern. Autonomous navigation is aided by a suite of instruments including a water pressure depth sensor, a fluid-bulb inclinometer, a DSP based sonar direction finder, a Doppler velocity log, a compass, and an underwater video camera with computer vision software.

The ORCA-VI follows the basic modular design philosophy of previous incarnations of ORCA. However, the structure has been reorganized for ease of use and in order to prepare to meet the more stringent guidelines of coming years.

Introduction

ORCA-VI is designed according to the guidelines of the 6th International Autonomous Underwater Vehicle Competition. The competition arena is located at the SPAWAR TRANSDEC facility in San Diego, California. The arena is an oval 200' wide and 320' long, with a flat bottom 16' deep. There is a 160' diameter semi-spherical depression in the middle that extends to a 38' depth at its center.

The competition arena will be divided into two parts: a competition half and a practice half. In the competition half of the arena will be a validation gate, a decision point with three arrows, and three bullseye targets. The validation gate is 10' by 6'. Each arrow near the decision point will have a bright indicator light at each end. Only one arrow will be lit during the run. Each target is composed of three stacked square trays with 5', 3', and 1' long edges. They are stacked with 1' vertical spacing with successively smaller area going up the stack.

The competing vehicles will have 15 minutes to complete the mission. Each vehicle must pass through the validation gate before attempting any other portion of the course. The vehicle then proceeds to the decision point, where it must identify and follow the lit arrow, and then find the correct target. The vehicle can drop up to two small markers on the target. More points are awarded for getting markers in the higher, smaller trays.

ORCA-VI was built to complete this mission reliably, repeatedly, and safely. The modularity of design allowed easy testing and modification throughout the process of construction. All of the modules were tested to insure safe operation.

Structural Overview

The hull of ORCA-VI has a single watertight compartment to house the computer and most of the electronics. The batteries and sensors are mounted on the aluminum frame in an open sensor bay below the tube. Two vertical thrusters, mounted at the bow and stern, control the vehicle's depth and pitch. Two horizontal thrusters at the sides control the forward velocity and heading of the submarine.

The vehicle is controlled by a single board computer running Linux. A spread-spectrum radio data link or an Ethernet tether may be used to communicate with the submarine computer.

The ORCA-VI controls its depth using feedback from a pressure sensor or sonar altimeter. Heading is controlled using feedback from a magnetic compass. The submarine can navigate in relation to an acoustic beacon with its four hydrophones. A Doppler Velocity Log system measures the velocity of the submarine relative to the ground. To recognize the visual cues and aim for the target, ORCA-VI uses a video camera and machine vision software.

Mechanical and Electrical Systems

The mechanical design of ORCA-VI is meant to be simple and modular. The frame was divided into four larger mechanical parts that could be constructed separately: the skeleton, the thruster mounts, the waterproof housings, and the sensor mounts.

The skeleton is made of 80/20 10-series T-slotted aluminum extrusions. Modifications can easily be made to the simple rectangular design. The slotted extrusions allow all of the components to slide into place for easy

mounting and vehicle trimming.

Each thruster mount is made of three aluminum pieces, welded together. One rectangular block attaches the mount to the 80/20 frame. A streamlined foil holds the thrusters away from the vehicle, without adding significant drag or blocking flow. A motor mount allows the cylindrical thruster body to be hose-clamped firmly to the end of the mount.

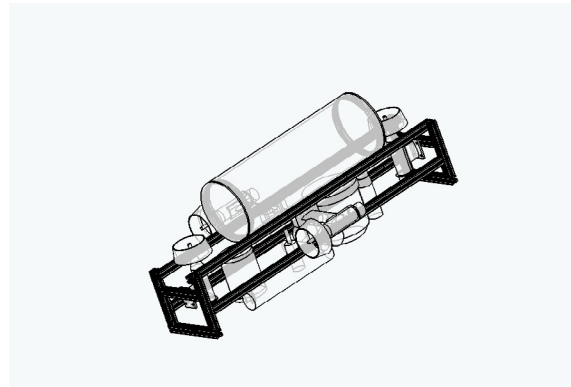

Wire frame drawing of ORCA-VI

The single dry compartment is a 27-inch long, eight-inch diameter PVC pipe. The hull is mounted on the aluminum frame and closed with PVC end plugs with double O-ring bore seals. Through-hull electrical connections are made with bulkhead connectors mounted into these end plugs. This compartment holds the computer, radio transceiver, antenna, motor drivers, and power electronics. The electronics are mounted on guide rails supported by parallel discs that slide inside the compartment. This assembly slides in and out of the dry compartment on Teflon rods used to prevent the discs from scraping the hull. This design allows maximum use of the volume of the compartment. The sliding electronics assembly can be removed without disconnecting any cables because a blind-mating multi-pin connector links the last disk to the compartment's PVC end plug.

The sensors and batteries are mounted

directly on the aluminum frame. This versatile design allows quick changing of the batteries. The batteries are placed low on the vehicle, to increase its righting moment, making the ORCA-VI passively stable in pitch and roll.

Thrusters

ORCA-VI uses the same thrusters in all four positions, attached via their mounts onto the aluminum frame. The thruster assemblies are provided by Inuktun Services Limited. Each one draws 7A at 24V producing approximately 15lbs of thrust.

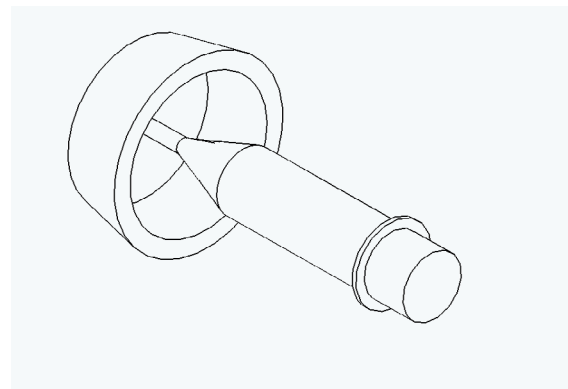

Wire frame drawing of Inuktun thruster

The Inuktun thrusters provide significantly better performance than the trolling motors used previously for horizontal thrusters. They provide almost twice the thrust that the trolling motors did at a given power level.

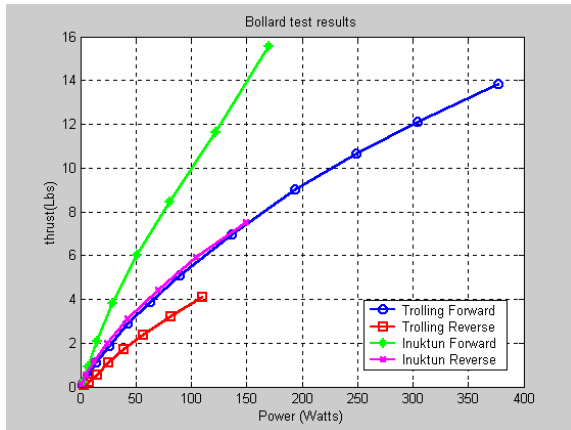

Plot of power in versus bollard thrust out for the Inuktun thrusters and our previous trolling motors

Their higher operating voltage means they require less current than a 12V motor which simplifies electronics layout inside the sub. Their light weight, 2.5lbs, provides 6lbs of weight savings (per motor) over the trolling motors.

Motor Control

Four Vantec RET713P motor drivers provide reversible speed control for the thrusters. These controllers were selected over the popular Novak SuperRoosters used on ORCA V because of their ability to drive 24V motors. A PIC microcontroller takes commands from the computer over an RS-232 port and generates the servo signals needed to operate the motor drivers. The servo signals connect to the motor drivers through 74OL6010 optoisolators to prevent coupling of electrical noise from the motors. There are two auxiliary channels powered off the motor batteries, controlled by the PIC microcontroller, one of which controls the drop mechanism.

Electrical Connections

Electrical connections through the hull are made with hermetically sealed locking multi-pin connectors. The connectors are rated to a depth of 80 m. Each outboard

component connects to the vehicle using its own receptacle mounted in the PVC end plug at the stern end of the electronics compartment. In addition to the outboard component connectors, there is a tether connector for development and testing.

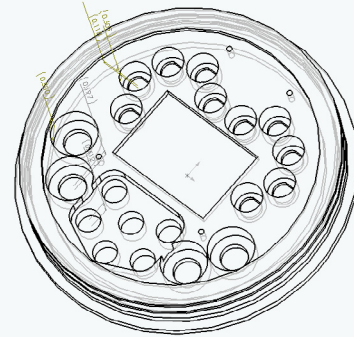

Wire frame drawing of endcap machined for through hull connectors

PCBs

ORCA-VI uses custom printed circuit boards extensively. These allow the use of small surface mount components, simplify wiring, and make for a neater, more robust submarine.

Power Supply

ORCA VI is powered by two separate power busses – one for the motors and motor drivers, another for the computer, electronics and sensors. Devices on these busses are individually fused to prevent an isolated failure from bringing the whole system down. Efficient boost and step down converters provide all voltages other than the battery voltages.

Power from the batteries is switched through a set of mechanical relays. Two waterproof magnetic kill switches with colored ripcords can be used to power down the motors or the computer.

The batteries are sealed in external battery pods that attach to the vehicle via through hull connectors. The electronics battery pods have 12 NiMH 4/3A cells wired in series giving a nominal voltage of 14.4 V and a capacity of 4 Ah. A single electronics battery pod powers the vehicle for two hours on a single charge. The motor battery pods have 20 NiMH SCU3300 cells wired in series giving a nominal voltage of 24V and a capacity of 3.3Ah. A pair of motor battery pods powers the motors for a half hour to an hour depending on use.

The use of external battery pods has the advantage of allowing the batteries to be changed much more quickly than if they were housed in the dry-hull.

Monitoring System

The vehicle is equipped with a power monitoring system. The voltage and current through the batteries and motors are read, and a PIC microcontroller reports values to the computer using a RS-232 serial interface. The monitoring system also has a temperature sensor to alert the operator to overtemperature conditions. Blown fuses are signaled with LEDs for fast identification.

Imaging - Vision Algorithm

The vision system that processes the output of the CCD camera is composed of two sections, a fast but imprecise detector and a higher precision, but slower, system for coordinating precise maneuvers at the target and direction markers. The fast system will consist of a simple intensity threshold filtered by color, in order to locate the bright LED emissions. The slower system for the direction marker discriminates the very bright section of the LED grid from the

small bright section of the single LED at the marker tip and determines a direction based on this information.

The coordination system for the target drop uses the center of mass of the brightest area, adjusted for submarine tilt, as a rough approximation, combined with edge detector output, for location based on target boundaries.

Sonar Range Finders

ORCA-VI uses two Tritech PA500 sonar range finders. One is used to measure the distance to the floor of the arena. The other is mounted on the starboard side and measures the distance to the sidewall for collision avoidance. The PA500 measures the distance to the bottom by actively pinging at 500KHz and measuring the time delay to the echo return. It returns the measured distance over an RS-232 serial port. The units are operable from 0.1 to 10 m distance, suitable for the size of the competition arena.

Depth Sensor

A Sensotec TJE series analog output pressure sensor measures the depth of the vehicle. A PIC microcontroller provides analog to digital conversion and communications to the main computer.

Doppler Velocity Log (DVL)

ORCA-VI is equipped with a "Workhorse Navigator" model 1200 Doppler Velocity Log from RD Instruments. The DVL measures the velocity of the vehicle relative to the bottom surface of the arena. The DVL also includes a digital compass module. This compass consists of a triaxial magnetometer and a two-axis fluid bulb inclinometer. The DVL outputs vehicle

heading, pitch, roll and two-dimensional bottom referenced velocity through an RS-232 serial port.

Passive Sonar System

The ORCA-VI includes a passive sonar system to determine the bearings to the acoustic beacons on the targets. The passive sonar unit is mounted to the 80/20 frame with a neoprene cover for acoustic decoupling from the frame.

The system detects pings using four hydrophones mounted in a pyramidal array. The hydrophones are mounted to the bottom of a waterproof enclosure, which contains processing electronics. The passive sonar system communicates with the ORCA-VI main computer using an RS-232 serial port. For each ping received, the unit transmits the bearing and elevation angle to the transmitter in degrees, the frequency of the ping, and the time in milliseconds since the last ping.

The system computes the angle to the pinger by measuring the time delay between the ping signal as received at each of the four hydrophones. The data acquisition and embedded computing hardware used are described in detail in the ORCA journal paper written for the 2002 AUVSI competition. Each hydrophone signal is digitized and input to a DSP microcomputer. The DSP bandpass filters and thresholds the signal from one hydrophone to find the start of each ping. The system captures the next 2 ms of signal from each hydrophone for further processing.

To determine the ping frequency, the system calculates a 2048-point FFT of one of the signals, and finds the maximum energy bin. The system then determines the time delay between each pairwise combination of

hydrophones, using the method of generalized cross-correlation as described in Underwater Signal and Data Processing by Joseph C. Hassab. The system uses only the first 150 microseconds of ping energy to determine the hydrophone pair delays, to reject multipath echoes.

To find the bearing and elevation angle to the pinger, the calculated delays are used to solve a system of simultaneous equations that gives the required angles in terms of the delays. The system of equations is overconstrained, so the program computes a least-squares optimal solution. The equations are derived from the geometry of the hydrophone array and the plane wave approximation.

The calculations for each ping take about 80ms. Once processing is complete, the bearing, elevation angle and frequency for the ping are transmitted to the main computer in an ASCII string for navigational use.

Control Computer

All navigation and control code is run under Linux on a Pentium-based PC/104+ embedded computer. This computing platform provides a stable and familiar programming environment, is amenable to remote operation, has modular standard peripherals and has a small install footprint. The ORCA-VI PC/104+ stack consists of a CPU card, a switching power supply, an eight serial port expansion card, and a frame grabber card. Most sensors and actuators interface to the computer using the RS-232 serial protocol.

Marker Drop Mechanism

The marker drop mechanism for ORCA-VI is comprised of a push-type solenoid with a

3/4" throw and PVC housing that holds two 5/8" steel ball bearings. The first ball bearing, upon being loaded, is held in place by two magnets that are located on either side of the inclined PVC tube. The solenoid is located directly behind the ball bearing, and the end of the plunger is nominally located less than 1/4" away from the end of the ball bearing. The return spring is located on the far end of the solenoid, away from the ball bearing and PVC housing.

When the solenoid is energized, the momentum from the solenoid plunger is transferred to the ball bearing. It then breaks free from the magnets' influence, travels 1" up the inclined tube, and drops out of a hole. To prevent the ball from overshooting the hole, the terminal end of the inclined PVC tube is angled and sealed. This ensures that the ball falls correctly down the hole with as little horizontal velocity as possible. After the first marker is fired and the solenoid plunger is retracted, the second ball falls into place via gravity and is held by the magnets.

The ball drop mechanism fits in a 6" x 3" x 3" bounding box. The entire mechanism weighs approximately 1 lb, including both ball bearings. The solenoid will be given its own high current through hull connector and requires a 24V source to ensure proper dropping operation.

Software Development

For development and testing purposes a tether can be attached to the vehicle to make communication with the computer possible. The computer uses the Sun RPC protocol to communicate with multiple on-shore computers. From each station the vehicle can be remotely operated with a joystick, and all variables and sensor values can be inspected and modified with a graphical user interface. In addition, the main control

program can be remotely modified and recompiled. All of this can be done while the submarine is submerged and operational. The control program has a simulation mode that uses a simple mathematical model of the pond and vehicle to generate simulated non-ideal sensor data in response to motor commands. The simulator employs a rudimentary graphical user interface and a simplified graphical mock-up of the area. The simulation mode allows control code to be developed and debugged in the lab before it is tested in the water.

Tether and Data Link

The wireless data link is a pair of Freewave DGRO frequency-hopping spread spectrum data transceivers. These devices operate over the 902-928 MHz frequency band, transmitting at 1 W. They connect to the host computer using an RS-232 serial port and have a maximum data rate of 115 kbps/sec. In air, they have a 20-mile line-of-sight range, but with one unit underwater, depth becomes the limiting factor. In a chlorinated swimming pool, the units perform well up to a depth of about 1 m. Communication with the vehicle can also be established using a tether which provides an Ethernet link to the computer and a live video feed from the CCD camera. This allows team members to watch what the vehicle is doing while submerged, which has proven useful when debugging complex autonomous maneuvers.

Mission Control Software

The mission control software is implemented as a multithreaded Java program. Each sensor has an associated driver thread that communicates with the device and scales its data into engineering units. An autopilot thread keeps the vehicle's depth, heading, pitch, and speed at desired

setpoints. The autopilot uses PID control on the four thrusters to servo the values returned by the pressure sensor, compass, inclinometer, and DVL to the desired setpoints.

Mission Plan

A pre-programmed state machine executes the mission plan. This section outlines the basic sequence of maneuvers the vehicle will use to complete the mission. Upon activation, the vehicle will dive to a cruising depth of 1.5 meters and will navigate through the validation gate using dead reckoning. Continuing to the decision point, the vehicle will use the visual cue of the lit indicator lights to determine which arrow to follow. When an image with the illuminated arrow is found, the image processing algorithm will give the heading of the arrow. The vehicle will use a look up table to determine the frequency of the designated target. The vehicle will wait for a ping with this target's frequency. The measured bearing to the target is added to the current

heading, giving a desired heading that the vehicle follows until it recognizes the target within the camera frame. The desired heading is updated each time a ping is received.

Once the target is recognized, the targeting algorithm is used to bring the bulls-eye into the center of the frame, at which point the marker is dropped and the vehicle surfaces indicating completion of the run.

Conclusion

The new mission for 2003 provided challenges that prompted several improvements on last year's vehicle. The thrusters, power supply, and DVL were changed to compete effectively. Additionally, the upcoming physical requirements encouraged our shift to a single dry compartment with external batteries. After the redesign and testing, we look forward to participating in the 2003 International AUV competition