

The role of the casimir effect in the static deflection and stiction of membrane strips in microelectromechanical systems (MEMS)

F. Michael Serry,^{a)} Dirk Walliser,^{b)} and G. Jordan Maclay

Department of Electrical Engineering and Computer Science, University of Illinois, Chicago, Illinois 60607

(Received 23 April 1998; accepted for publication 3 June 1998)

We present an analysis describing how the Casimir effect can deflect a thin microfabricated rectangular membrane strip and possibly collapse it into a flat, parallel, fixed surface nearby. In the presence of the attractive parallel-plate Casimir force between the fixed surface and the membrane strip, the otherwise flat strip deflects into a curved shape, for which the derivation of an exact expression of the Casimir force is nontrivial and has not been carried out to date. We propose and adopt a local value approach for ascertaining the strength of the Casimir force between a flat surface and a slightly curved rectangular surface, such as the strip considered here. Justifications for this approach are discussed with reference to publications by other authors. The strength of the Casimir force, strongly dependent on the separation between the surfaces, increases with the deflection of the membrane, and can bring about the collapse of the strip into the fixed surface (stiction). Widely used in microelectromechanical systems both for its relative ease of fabrication and usefulness, the strip is a structure often plagued by stiction during or after the microfabrication process—especially surface micromachining. Our analysis makes no assumptions about the final or the intermediate shapes of the deflecting strip. Thus, in contrast to the usual methods of treating this type of problem, it disposes of the need for an ansatz or a series expansion of the solution to the differential equations. All but the very last step in the derivation of the main result are analytical, revealing some of the underlying physics. A dimensionless constant, K_c , is extracted which relates the deflection at the center of the strip to physical and geometrical parameters of the system. These parameters can be controlled in microfabrication. They are the separation w_0 between the fixed surface and the strip in the absence of deflection, the thickness h , length L , and Young's modulus of elasticity (of the strip), and a measure of the dielectric permittivities of the strip, the fixed surface, and the filler fluid between them. It is shown that for some systems ($K_c > 0.245$), with the Casimir force being the only operative external force on the strip, a collapsed strip is inevitable. Numerical estimates can be made to determine if a given strip will collapse into a nearby surface due to the Casimir force alone, thus revealing the absolute minimum requirements on the geometrical dimensions for a stable (stiction-free) system. For those systems which do exhibit a stiction-free stable equilibrium state, the deflection at the middle of the strip is always found to be smaller than $0.48w_0$. This analysis is expected to be most accurately descriptive for strips with large aspect ratio (L/h) and small modulus of elasticity which also happen to be those most susceptible to stiction. Guidelines and examples are given to help estimate which structures meet these criteria for some technologically important materials, including metal and polymer thin films. © 1998 American Institute of Physics. [S0021-8979(98)07517-3]

I. INTRODUCTION

By virtue of their very presence, material bodies alter in and around the space they occupy the spectrum of the zero point vacuum electromagnetic field. This can give rise to Casimir forces between material bodies in proximity to each other. Casimir forces can be attractive or repulsive depending on the geometry of the material bodies.¹⁻³ In the first published paper on this subject, Casimir derived an expression for such a force as it exists between parallel, flat, semi-infinite slabs of perfect conductors at zero temperature.⁴ Covariant calculations of the force for this same geometry were

first performed by Brown and Maclay using the stress-energy tensor, and included corrections due to finite temperature.⁵ Elizalde and Romero published a review article on the subject in 1990.⁶ More recently, Casimir forces have been the subject of a fair number of theoretical studies (see, for example, Refs. 7–12). Experimental investigations have also been carried out in the last few years which confirm some of the theory.^{13,14} Also recently, the notion that useful exchange of energy with the vacuum in a controlled fashion might be possible has received renewed attention, and Casimir forces are considered important for experimental investigations in this area.^{15,16}

From a technological viewpoint, one area in which Casimir forces already demand attention is that of microelectromechanical systems (MEMS). Casimir forces can and do play a significant role in micro- and nanometer-size struc-

^{a)}Corresponding author; currently at Digital Instruments, Inc., 112 Robin Hill Road, Santa Barbara, CA 93117; electronic mail: serry@di.com

^{b)}Currently at Daimler-Benz Research Division, Frankfurt, Germany.

tures for two reasons. First, these forces (per unit area), typically varying with the third or fourth power of the separation between the material bodies, are strongest when this separation is in the submicrometer regime. Second, many devices are now fabricated small and therefore light enough, and with moving parts in close enough proximity that Casimir forces can complicate fabrication and significantly affect actuation and device performance.^{17,18} With continuing reduction in the size and separation of structures, Casimir forces will need to be accounted for increasingly in the design and modeling of MEMS and nanoelectromechanical systems (NEMS). In the near future, the most likely Casimir force to play a consequential role in these systems is the parallel-plate Casimir force, which attracts two adjacent flat parallel plates towards each other, and which will be referred to simply as the Casimir force hereafter. We will show that at the present the Casimir force (equivalent in this geometry to the attractive retarded van der Waals force) is in part responsible for stiction in a large number of MEMS, wherein the stiction is often encountered during and after the removal of sacrificial layers in surface micromachining of transducers. This problem is technologically important, because it adversely affects the production yield on batch fabricated devices, and also plagues many devices in operation. A substantial amount of research and development is underway towards the understanding of and finding solutions for stiction (see, for example, Refs. 19–23).

The Casimir force F_c (per unit area) is proportional to the inverse fourth power of the separation, d , between the plates, viz.,

$$F_c = \eta \mathfrak{R} / d^4, \quad (1a)$$

$$\mathfrak{R} \equiv \hbar c \pi^2 / 240, \quad (1b)$$

$$\eta \leq 1, \quad (1c)$$

where η depends on the dielectric permittivities of the plates and of the medium between them ($\eta=1$ for perfectly conducting plates with vacuum between them).^{4,24,25} This parameter is generally larger than 0.5 if one of the Casimir surfaces is metal coated. The value of η for a given system can be found using Refs. 26 and 27. \hbar and c have their usual meanings.

A 2- μm -thick, highly doped (doping density $\geq 10^{20} \text{ cm}^{-3}$) and thus highly conductive single-crystal silicon membrane is attracted towards a nearby parallel metal plate under a Casimir force approximately equal to the weight of the membrane when the separation is 0.4 μm . At 0.25 μm separation, the force is roughly equivalent to that which would be present if a 50 mV potential difference were applied between the membrane and the metal plate. At 0.1 μm separation, the equivalent potential difference would be 200 mV. The Casimir force per unit area is approximately 1 atm strong at 10 nm separation between two metal plates.

In this article, we consider the Casimir force in a class of microfabricated structures which are nearly, but less than perfectly, parallel. Specifically, we are concerned with two objects, the first of which is rigid and flat, and the second of which is a rectangular membrane strip, flexible enough to elastically deflect towards the first under the Casimir force

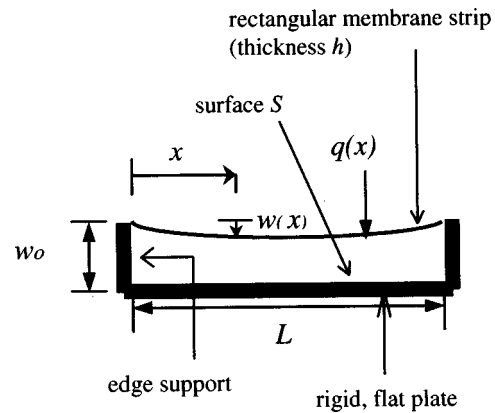

FIG. 1. Cross section of a MEMS membrane strip (e.g., fabricated by surface micromachining): a rectangular membrane supported on two of its edges, at $x=0$ and $x=L$. The drawing is not to scale; in reality, the strip is much longer than it is thick ($L \gg h$) and the aspect ratio is much smaller ($w_0 \ll L$).

(Fig. 1). The rectangular membrane strip of uniform thickness h is supported on two opposite edges (fixed edges) a distance L apart, and is free along the other two edges. This structure is an ubiquitous MEMS building block; in light of its versatility and relative ease of fabrication (especially in surface micromachining,) it is now made with a variety of materials, ranging from single-crystal silicon, over polymers, to metals.^{28–34} The main objective of this analysis is to relate the static deflection at the center of the membrane strip to a number of physical and geometric parameters which can be controlled in microfabrication. In reaching this objective, the analysis also reveals some important features of the system under study.

Due to proximity to the rigid flat top surface S of the bottom plate (Fig. 1), the strip is subject to the attractive Casimir force, and deflects into a curved shape. In the absence of deflection, the separation between the bottom surface of the strip and the surface S would be w_0 . If the strip has not collapsed into the surface S , the departure, due to the deflection, from the parallel-plate configuration may be considered small all along the length of the strip in a large class of real devices, where the typical aspect ratio L/w_0 is 100 or greater. The thickness, h , of the strip is also considered much smaller than L ; this will be elaborated on in Sec. III.

II. THE LOCAL VALUE APPROACH

In almost all of the attempts made to date at measuring the parallel-plate Casimir force, one or two slightly curved surfaces have been used instead of two flat surfaces in order to reduce the difficulty of maintaining the surfaces parallel. Yet, in these attempts, the parallel-plate form [Eqs. (1)] have been assumed for the force despite the departure, albeit small, from the parallel configuration (see, for example, Ref. 35). The justification for this has been the following: that for large enough radii of curvature and for small enough separations between the adjacent surfaces, that is, small enough separations so that the force is significant, the parallel-plate geometry is adequately approximated and thus Eqs. (1) remain valid. In a recent exception, Lamoreaux used an alter-

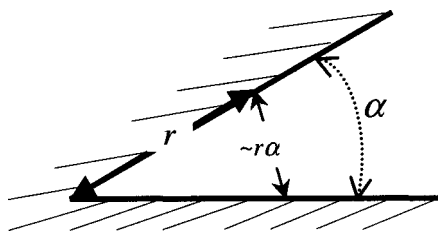

FIG. 2. Two flat conductive semi-infinite plates defining a wedge of angle α and a cusp. For small values of r and α , the strength of the Casimir pressure varies nearly with the inverse fourth power of the local value of the separation, $r\alpha$, between the plates, i.e., $F \propto (r\alpha)^{-4}$.

native to Eq. (1a), by accounting for the *known* radius of curvature of a *rigid* hemispherical lens, which he used as one of the Casimir plates in his experiment; the other plate, also rigid, was flat.¹³ Theoretical approaches involving perturbation methods have been applied to explore the force in geometries with *known*, and *fixed* departures from the parallel configuration. For example, Zayaev and Mostepanenko have used a perturbation approach to calculate corrections to Eq. (1a) for the case where one surface is rigid and flat, and the second surface is also rigid, but curved, yet nonspherical.³⁶ In contrast, the analysis of the static deflection of the membrane strip which we embark on presently lacks the benefits of the rigidity of the strip, and of the knowledge of its form. That is to say, the final shape of the *flexible* strip in the state of stable mechanical equilibrium is not known to us, and neither are the intermediate shapes through which one tacitly assumes the strip to have evolved in reaching the energetically favorable state of static deflection. We need an alternative approach to describe the static deflection of the membrane strip under the Casimir force. In the absence of an exact expression for the Casimir force on a curved surface with an unknown shape, a shape which evolves due indeed to the action of the force itself, we propose an alternative approach as described next along with the reasoning which leads up to it.

Deutsch and Candelas in 1979 derived an exact expression for the (attractive) Casimir force between two perfectly conducting, semi-infinite plates with flat surfaces at an angle to each other so as to define a wedge, such as in Fig. 2.³⁷ Brevik and Lygren arrived at the same results in 1996 using a different approach.³⁸ These results show the following: that for a wedge of angle α , at a small distance, r , from the cusp of the wedge, the strength of the Casimir force per unit area on either surface of the wedge is a function of the product, $r\alpha$, which for small values of α approaches the local value of the separation between the surfaces (Fig. 2). Furthermore, these results show that the force per unit area varies very nearly as the inverse fourth power of the separation—same as in the parallel-plate geometry—and accepts extremely small corrections to this form, $(r\alpha)^{-4}$, for small values of α , with the correction reaching only 1% at $\alpha=0.1$ rad (5.7°). In our system, the curvature of the deflected membrane strip is assumed negligible enough so that at all points along the length of the strip, the tangent to the strip makes an angle less than 0.1 rad with S . This assumption is especially well justified where it matters the most: away from the supported

edges, i.e., in the midsection of the strip where the deflection and thus the force are the largest. Under these assumptions and inspired by the results of Deutsch, Candelas, Brevik, and Lygren, we propose and adopt a local-value approach to the force strength. We propose that, during the deflection and in the final curved configuration of the membrane strip, the value of the Casimir pressure at a point along the length of the strip is given by Eq. (1a), where now d is the local value of the separation between the strip and the surface, S .

III. THE DIFFERENTIAL EQUATION OF THE PLATE STRIP AND THE MEMBRANE APPROXIMATION

The membrane strip differential equation is a special case of a plate strip differential equation, which describes the deflection $w(x)$ of a thin plate strip of uniform thickness h in a static equilibrium condition under the load $q(x)$, which is perpendicular to the undeformed plane of the plate (i.e., a lateral load). The plate strip differential equation is fourth order in x :³⁹

$$D \frac{d^4 w(x)}{dx^4} + N \frac{d^2 w(x)}{dx^2} = -q(x), \tag{2a}$$

where D , the flexural rigidity of the plate strip, is defined as

$$D \equiv \frac{Eh^3}{12(1-\nu^2)}, \tag{2b}$$

with E and ν denoting the Young modulus of elasticity and the Poisson ratio, respectively, of the material of the strip. N , to be discussed shortly, is a force per unit width of the strip. We consider the plate strip subject to the fixed-fixed boundary conditions. That is to say, the supported edges are not free to approach each other as the strip deflects, and furthermore, the slope of the strip, dw/dx , is zero at these edges. This boundary condition is appropriate for the great majority of microfabricated plate strips.

Bending and stretching are assumed to be the two mechanisms by which the lateral load is carried in the strip. The bending is represented by the fourth order term in Eq. (2a). The stretching is represented by the second order term, in which the so-called middle surface membrane forces, N , are in-plane forces, assumed to exist in a plane halfway through the thickness of the plate. This plane is considered a neutral plane, which means that the in-plane stresses developed *as a result of the bending* may be neglected on this plane. Instead, the main contribution to N comes from the membrane-type *stretching* of the strip in response to the lateral load.³⁹

If the stretching is negligible, then we have the case of pure bending of the plate strip, and the second order term may be dropped from the differential equation [Eq. (2a)]. If the bending behavior is insignificant and can be neglected, then the external load may be assumed to be carried almost entirely by the membrane forces N . An example of this would be the behavior of a strip with a large enough aspect ratio L/h as will be discussed later in Sec. III.⁴⁰⁻⁴² The strip may then be well approximated as a flexible membrane strip,

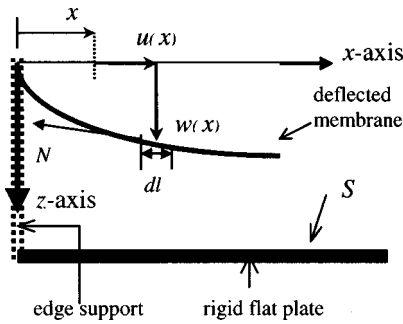

FIG. 3. Membrane strip deflection (cross section): an element of length dl , originally a distance x away from the left edge, is displaced by an amount $u(x)$ in the x direction and by an amount $w(x)$ in the z direction. This is not to scale; the curvature is exaggerated.

which carries the external load mainly by stretching out in the plane of the strip. The differential equation then reduces to the second order in x :^{39,43}

$$N \frac{d^2w(x)}{dx^2} = -q(x). \tag{3}$$

A clear-cut criterion for determining whether a strip is to be treated as a membrane strip or a plate strip does not exist, and experimental data are needed to address this issue in microfabricated structures. However, the ratio,

$$\frac{L^2N}{4D} (\equiv \gamma),$$

is a useful quantity to investigate in assessing which of the two mechanisms, bending or stretching, if either, is the dominant one in carrying the external load.^{39,43} Larger values of γ imply stronger membrane behavior. We will return to this quantity, γ in order to probe the role of the aspect ratio, L/h , and of the elasticity in determining the relative importance of bending and stretching.

The deflection of the membrane strip decreases the separation; this in turn increases the magnitude of the Casimir force. This therefore is a system with positive feedback and is potentially subject to instability. However, if the strip is resistant enough, after some deflection and before membrane contact with the surface S , the effect of the Casimir force on the membrane is countered by the development of restoring membrane forces N , which arise due to the deflection. For a given set of parameters, which includes membrane thickness and length, we expect the stable static equilibrium state, if existent, to correspond to a single particular value of the deflection of the points midway along the length of the membrane strip at $x=L/2$. Unless otherwise specified, membrane deflection shall be understood hereafter as the deflection at $x=L/2$.

Adopting the local-value approach (Sec. II) to the force strength, the differential equations and boundary conditions describing the static equilibrium of the membrane strip are for $0 \leq x \leq L$ (Figs. 1 and 3):

$$-Nw''(x) = \eta\mathfrak{R}[w_0 - w(x)]^{-4}, \tag{4a}$$

$$N' = 0, \tag{4b}$$

$$N = Eh[u'(x) + \frac{1}{2}w'^2(x)], \tag{4c}$$

$$u(0) = u(L) = 0, \tag{5a}$$

$$w(0) = w(L) = 0, \tag{5b}$$

where $u(x)$ and $w(x)$ are the x and z components, respectively, of the displacement vector for a membrane element of length, dl , as shown in cross section in Fig. 3.⁴⁴ A prime denotes differentiation with respect to x . Equation (4a) is the same as Eq. (3), but with the load $q(x)$ replaced by the Casimir pressure (load) at a distance x from the left edge of the membrane strip. In cases where initial in-plane stresses exist, N receives an additive contribution from these stresses, which we leave out in this study. In static equilibrium, for a given deflection at the center of the strip, the magnitude of N is constant along the length of the membrane [Eq. (4b)]. The strain, ϵ_{xx} , in the x direction is related to the displacements by⁴⁴

$$\epsilon_{xx} = u'(x) + (1/2)w'^2(x), \tag{6}$$

and is seen from Eqs. (4b) and (4c) to be independent of x .

Using Eq. (4c) and the definition of the flexural rigidity [Eq. (2b)], the parameter γ can be written in terms of the aspect ratio, L/h , and the expression [Eq. (6)] for the strain ϵ_{xx} :

$$\gamma = \left(\frac{L}{h}\right)^2 \left(\frac{u' + (1/2)w'^2}{12(1-\nu^2)}\right). \tag{7}$$

To the best of our knowledge, a clear-cut criterion (a critical value for γ) has not been cited in the published literature to distinguish the pure bending behavior from the pure membrane-type behavior. Indeed, it is expected that the transition from one to the other is a gradual one. We adopt the criterion set forth implicitly by Mansfield for distinguishing those strips to which the membrane approximation does apply, namely, for the flexural rigidity, and thus the bending to be neglected safely, γ should be about 400 or larger.⁴³ The role of the aspect ratio (L/h) is clear. The role of the elasticity of the material is less obvious, however, especially since Young's modulus does not appear in Eq. (7). The contribution of the Poisson ratio does not vary much with different materials, because this parameter is almost always less than about 0.5 for materials of interest in MEMS and it appears to the second power in Eq. (7). The significance of the elasticity of the material is reflected largely in the presence of the strain, $\epsilon_{xx} [= u'(x) + \frac{1}{2}w'^2(x)]$, in the numerator of the right-hand side in Eq. (7). The maximum elastic strain that a material can support determines the upper limit on ϵ_{xx} , and thus the lower limit on the aspect ratio L/h if the restriction on γ is to be met. For steel and aluminum alloys, for example, the maximum elastic strain is about 0.004. This puts a lower limit of about 1000 on the aspect ratio. For some polymers capable of supporting much larger elastic strains, the aspect ratio can be considerably smaller in order for the membrane theory to apply. However, we consider the assumption of small slopes (dw/dx) essential to the line of reasoning which lead up to the proposed local-value approach to the Casimir force strength on a curved surface. Therefore, for deflections large enough to put in question the

validity of the local-value approach, the analysis presented here will not apply, even if the membrane criterion (restriction on γ) is met. Experimental data are needed to address these issues. Our methodology will likely prove best suited for application to those strips wherein either the aspect ratio L/h , or the maximum elastic strain possible, or both, are quite large. Such strips also happen to be those most susceptible to the problem of stiction.

IV. THE ANALYSIS

Multiplying Eq. (4a) by $w'dx$ and integrating indefinitely once, we arrive at the expression

$$(N/2)w'^2(x) - (\eta\mathfrak{R}/3)[w_0 - w(x)]^{-3} = \phi, \quad (8)$$

where ϕ is a constant. At $x=L/2$ (the center of the strip) the slope of the strip is zero; ϕ is thus found to be the Casimir energy at $x=L/2$:

$$\phi = -(\eta\mathfrak{R}/3)[w_0(1 - \delta_{L/2})]^{-3}, \quad (9)$$

where we have defined the normalized deflection and its value at $x=L/2$,

$$w(x)/w_0 \equiv \delta(x), \quad (10a)$$

$$\delta(L/2) \equiv \delta_{L/2}. \quad (10b)$$

Equation (8) can now be recast in dimensionless form, viz.,

$$(Nw_0^5/2\eta\mathfrak{R})\delta'^2(x) - \frac{1}{3}[1 - \delta(x)]^{-3} = -\frac{1}{3}(1 - \delta_{L/2})^{-3}. \quad (11)$$

Now we solve Eq. (4c) for $u'(x)$, multiply through by dx , and then integrate over the entire length of the strip. Using the boundary conditions on $u(x)$ [Eq. (5a)], we arrive at

$$\frac{NL}{Eh} = \frac{w_0^2}{2} \int_0^L \delta'^2(x) dx. \quad (12)$$

This quantity has the units of length. We note that the ratio NL/Eh on the left-hand side is the strain in the x direction [Eqs. (4c) and (6)] multiplied by the full length of the membrane prior to deflection. Therefore, the expression on the right-hand side is the difference between the length of the membrane before and after the deflection.

Using Eq. (8) and the symmetry of the geometry about $x=L/2$, Eq. (12) may be transformed ($d\delta = \delta dx$) into an integral over the dimensionless quantity δ for $0 \leq \delta \leq \delta_{L/2}$:

$$\begin{aligned} \frac{N^{3/2}L}{Eh} \sqrt{\frac{3w_0}{2\eta\mathfrak{R}}} &= \int_0^{\delta_{L/2}} \sqrt{(1 - \delta)^{-3} - (1 - \delta_{L/2})^{-3}} d\delta. \end{aligned} \quad (13)$$

We next solve for $\delta(x)$ from Eq. (11), perform a separation of the variables, and integrate over half the length of the membrane (i.e., $0 \leq x \leq L/2$, $0 \leq \delta \leq \delta_{L/2}$):

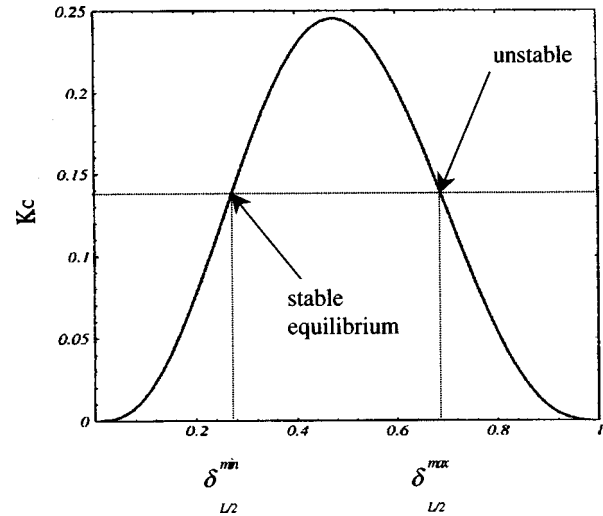

FIG. 4. For each value of $K_c < 0.245$, a stable and an unstable equilibrium state exist; the stable equilibrium position of the center of the strip is always less than $0.48w_0$. For $K_c > 0.245$, membrane strip collapses into the surface S .

$$\sqrt{(\mathfrak{R}L^2)/(6Nw_0^5)} = \int_0^{\delta_{L/2}} d\delta [(1 - \delta)^{-3} - (1 - \delta_{L/2})^{-3}]^{1/2}. \quad (14)$$

Eliminating N from Eqs. (13) and (14), we arrive at an expression for the dimensionless system characteristic constant, which we define as K_c :

$$\begin{aligned} \frac{\mathfrak{R}L^4}{Ehw_0^7} (\equiv K_c) &= 12 \left(\int_0^{\delta_{L/2}} \sqrt{(1 - \delta)^{-3} - (1 - \delta_{L/2})^{-3}} d\delta \right) \\ &\times \left(\int_0^{\delta_{L/2}} \frac{d\delta}{\sqrt{(1 - \delta)^{-3} - (1 - \delta_{L/2})^{-3}}} \right)^3. \end{aligned} \quad (15)$$

The expression on the right-hand side is not integrable in closed form. We perform a numerical integration (MATHEMATICA, Wolfram Research, Inc.) for each and every value of $\delta_{L/2}$ between zero and unity, which corresponds to the case of the membrane strip in contact with the surface S . The result is shown in Fig. 4, which is a plot of K_c versus the normalized deflection, $\delta_{L/2}$ (plotted along the bottom axis). This plot relates, in static equilibrium, the geometrical and physical parameters of the system to the normalized deflection at the center of the membrane strip.

Figure 4 shows that, for a given value of $K_c < 0.245$, there are two corresponding values for $\delta_{L/2}$. The interpretation of this can be found in an earlier study of an anharmonic Casimir oscillator (ACO), a system similar to the one studied presently but simpler.⁴⁵ In summary, the results of the ACO study guide us to conclude that, in the present system, the smaller value of $\delta_{L/2}$, which we call $\delta_{L/2}^{\text{min}}$, defines a stable static equilibrium state. This state is the state of minimum potential energy for the membrane strip, subject to the Casimir force and in the absence of any other external forces. Here, the Casimir force deflects the strip, which is restrained from collapsing into the surface S by the elastic restoring forces, represented by N , which develop as a result of the

deflection. The larger value, $\delta_{L/2}^{\max}$, corresponds to an unstable static equilibrium state. For a given system, if the membrane strip is by the action of an external force (other than the Casimir force) pushed past $\delta_{L/2}^{\min}$ nearer the fixed surface S , it will collapse into S for large enough additional deflection. There exists the theoretical possibility that this external force will deflect the strip in such a way that the strip assumes a form which satisfies the differential Eqs. (4), and the boundary conditions (5), and with $\delta_{L/2} = \delta_{L/2}^{\max}$. The strip can then theoretically stay in this unstable equilibrium indefinitely if the external force were removed and no perturbations were present. For details, please see Ref. 45.

Figure 4 also reveals two salient features of the system under study. First, with nothing other than the Casimir force loading the strip, the strip will collapse if K_c is larger than the critical value 0.245. This provides a way to check if a system of given dimensions and material properties will have a stable equilibrium position in the absence of other forces, such as an electrostatic actuation force, or a capillary force during and after the wet etching of a sacrificial layer. For example, in a system where the strip is 500- μm -long, 1- μm -thick, and made of a polymer with $E \equiv 10^9$ Pa, and where a thin film of gold is deposited on both the surface S and the polymer strip to act as electrodes (i.e., $\eta \approx 1$), the strip will collapse due to the Casimir effect alone if w_0 is roughly 0.8 μm or smaller. The second important feature of this system as revealed in Fig. 4 is that, regardless of the dimensions and physical properties of the system, the stable equilibrium state, if existent (i.e., if $K_c < 0.245$), always corresponds to a deflection of less than about $0.48w_0$ at the midpoint of the strip at $x = L/2$.

As stated earlier, the degree of accuracy of the analysis presented here improves with increasing aspect ratio (L/h) and with elasticity of the strip material. Polymers in general, and especially highly elastic polymers with low glass transition and high melting temperatures, are becoming more attractive as materials for fabricating MEMS transducers.^{30,31,46} This is in part because the fabrication and curing temperatures of many polymers are low enough to facilitate integration of polymer-based transducers with fabricated complementary metal-oxide-semiconductor (CMOS) chips. Other reasons include the flexibility in changing functional groups on the polymers for sensing applications and a wide range of elastic properties to choose from. The membrane model presented here should prove useful in some microfabricated devices which employ polymers and other highly elastic films as transducers.

¹G. Plunien, B. Muller, and W. Greiner, Phys. Rep. **134**, 87 (1986).

²K. A. Milton, L. L. DeRaad, Jr., and J. Schwinger, Ann. Phys. **115**, 388 (1978).

³T. H. Boyer, Phys. Rev. **174**, 1764 (1968).

⁴H. B. G. Casimir, Koninkl. Ned. Adak. Wetenschap. Proc. **51**, 793 (1948).

⁵L. S. Brown and G. J. Maclay, Phys. Rev. **184**, 1272 (1969).

⁶E. Elizalde and A. Romero, Am. J. Phys. **59**, 711 (1991).

⁷I. Y. Sokolov, Phys. Lett. A **223**, 163 (1996).

⁸S. J. van Enk, Phys. Rev. A **52**, 2569 (1995).

⁹S. Weigert, Phys. Lett. A **214**, 215 (1996).

¹⁰P. Suppes and A. S. Sant'Anna, Found. Phys. Lett. **9**, 213 (1996).

¹¹I. R. Senitzky, Phys. Rev. A **57**, 40 (1998).

¹²R. Blanco, K. Dechoum, H. M. França, and E. Santos, Phys. Rev. A **75**, 724 (1998).

¹³S. K. Lamoreaux, Phys. Rev. Lett. **78**, 5 (1997).

¹⁴E. Hinds, Phys. Rev. Lett. **70**, 560 (1993).

¹⁵R. L. Forward, Phys. Rev. B **30**, 1700 (1984).

¹⁶D. C. Cole and H. E. Puthoff, Phys. Rev. E **48**, 1562 (1993).

¹⁷T. Hirano, T. Furuhashi, K. J. Gabriel, and H. Fujita, J. Microelectromech. Syst. **1**, 52 (1992).

¹⁸W. Chen and H. Ahmed, Appl. Phys. Lett. **63**, 1116 (1993).

¹⁹N. Tas, T. Sonnenberg, H. Jansen, and R. Legtenberg, J. Micromech. Microeng. **6**, 385 (1996).

²⁰T. Abe and M. L. Reed, J. Micromech. Microeng. **6**, 213 (1996).

²¹R. Legtenberg, H. A. C. Tilmans, J. Elders, and M. Elwenspoek, Sens. Actuators A **43**, 230 (1994).

²²T. Abe, W. C. Messner, and M. L. Reed, J. Microelectromech. Syst. **4**, 66 (1995).

²³M. R. Houston, R. T. Howe, and R. Maboudian, in Proceedings of the International Conference on Solid-State Sensors and Actuators (Transducers) and Eurosensors, Stockholm, Sweden, June 1995.

²⁴B. V. Derjaguin, Y. I. Rabinovich, and N. V. Churaev, Nature (London) **272**, 313 (1978).

²⁵The mathematical expression for the parallel-plate Casimir force here is the same as that of the attractive retarded van der Waals dispersion force between two parallel flat plates of solids. Although in this geometry they are equivalent, in general Casimir forces and van der Waals forces are not the same. For an in-depth treatment of the similarities and differences in the case of the parallel-plate geometry, see Refs. 26 and 27.

²⁶E. M. Lifshitz, Sov. Phys. JETP **2**, 73 (1956).

²⁷B. V. Derjaguin, N. V. Churaev, and V. M. Muller, *Surface Forces* (Consultants Bureau, New York, 1987), Chap. 4.

²⁸H. A. C. Tilmans and R. Legtenberg, Sens. Actuators A **45**, 67 (1994).

²⁹C. H. Mastrangelo and C. H. Hsu, J. Microelectromech. Syst. **2**, 33 (1993).

³⁰M. Pederson, W. Olthuis, and P. Bergveld, Sens. Actuators A **63**, 97 (1997).

³¹M. Husak, J. Micromech. Microeng. **7**, 173 (1997).

³²C. Goll, W. Bacher, B. Bustgens, D. Maas, R. Ruprecht, and W. K. Schomburg, J. Micromech. Microeng. **7**, 224 (1997).

³³C. Linder and N. F. De Rooij, Sens. Actuators A **21–23**, 1053 (1990).

³⁴P. R. Scheeper, J. A. Voorthuyzen, W. Olthuis, and P. Bergveld, Sens. Actuators A **30**, 231 (1992).

³⁵D. Tabor and R. H. S. Winterton, Nature (London) **219**, 1120 (1968).

³⁶Y. B. Zayadev and V. M. Mostepanenko, Teor. Mat. Fiz. **79**, 209 (1989). English translation available from Plenum Publishing Corporation under the call number 004-5779/89/7902-0487.

³⁷D. Deutsch and P. Candelas, Phys. Rev. D **20**, 3063 (1979).

³⁸I. Brevik and M. Lygren, Ann. Phys. **251**, 157 (1996).

³⁹S. Timoshenko, *Theory of Plates and Shells*, 1st ed. (McGraw-Hill, New York, 1940), Chap. VIII.

⁴⁰This is also the case for some plates which do not necessarily meet the thickness-to-length aspect ratio requirement, but which are subject to deflections much larger than the thickness of the plate. This subject is recently investigated in some detail in Refs. 41 and 42.

⁴¹H. A. Erbay, Int. J. Eng. Sci. **35**, 151 (1997).

⁴²H. A. Erbay and E. S. Shuhubi, Int. J. Eng. Sci. **29**, 467 (1991).

⁴³E. H. Mansfield, *The Bending and Stretching of Plates*, 2nd ed. (Cambridge University Press, Cambridge, 1989), Chap. 9.

⁴⁴A. D. Kerr and D. W. Coffin, J. Appl. Mech. **57**, 128 (1990).

⁴⁵F. M. Serry, D. Walliser, and G. J. Maclay, J. Microelectromech. Syst. **4**, 193 (1995).

⁴⁶J. C. Lotters, W. Olthuis, P. H. Veltink, and P. Bergveld, J. Micromech. Microeng. **7**, 145 (1997).