



DEPARTMENT OF
AERONAUTICS AND ASTRONAUTICS

CAMBRIDGE, MASSACHUSETTS 02139
ROOM 33-208 (617) 253-2260

WRITTEN QUALIFYING EXAMINATION
FOR
DOCTORAL CANDIDATES

Tuesday, January 22, 1991

37-212

9:00 a.m. - 1:00 p.m

• CLOSED BOOK AND NOTES •

Answer a total of five (5) questions (no more or less).

You must answer at least two (2) questions from Column A.

Please answer each question on a separate sheet (or sheets). *Do not put the answers to different questions on the same sheet of paper!*

Be sure that your name appears on *every* sheet of paper you turn in.

Oral examinations will be held Tuesday, January 29, 1991.

Results will be available Wednesday, January 30, 1991.

Column A

Mathematics

Physics

Dynamics

Column B

Instrumentation, Guidance and Control

Fluids

Structures

Propulsion

Systems

Thermodynamics

Avionics

Bioengineering

Mathematics
Written Exam Question

Explain how the knowledge of eigenvalues and eigenfrequencies (natural frequencies) and their associated eigenvectors and eigenmodes (natural modes) can be used to solve the following two initial value problems. In each case you should determine the eigenvalues, eigenfrequencies, eigenvectors and/or eigenmodes, and explain in detail how the general solution is constructed.

a)

$$\frac{d}{dt} \begin{pmatrix} u_1 \\ u_2 \end{pmatrix} = \begin{pmatrix} 3 & 4 \\ -1 & -2 \end{pmatrix} \begin{pmatrix} u_1 \\ u_2 \end{pmatrix}$$

with initial conditions $u_1(0) = a$
 $u_2(0) = b$

b)

$$\frac{\partial}{\partial t} u(x,t) = \frac{\partial^2 u(x,t)}{\partial x^2}$$

with boundary conditions $u(0,t) = u(1,t) = 0$

and initial condition $u(x,0) = f(x)$

Physics
Written Exam Question

The Michelson-Morley interferometer is familiar from its role in disproving the “ether” hypothesis. However, the same apparatus is nowadays used to obtain high resolution optical spectra (in competition with prisms, gratings, etc.). Explain how this works.

- (a) Let $\alpha(\omega)$ be the amplitude and $\phi(\omega)$ the phase of light of frequency ω incident on the beam splitter (hence its intensity, or mean-squared amplitude, will be $I(\omega) = \frac{1}{2} \alpha^2(\omega)$). Let $2L_1$ and $2L_2$ be the lengths of the two paths to the mirrors and back to the splitter. Assume the splitter passes 50% of the light and reflects the rest. Derive an expression for the intensity $I_2(\omega)$ of the observed light of that frequency.

- (b) The total observed intensity is $I_2 = \int_0^{\infty} I_2(\omega) d\omega$. Suppose one arm's length, say L_1 , is systematically varied, and the function $I_2(L_1)$ recorded. What mathematical operation can then be used to extract the spectrum $I_1(\omega)$ from this record?

Physics

Written Exam Question

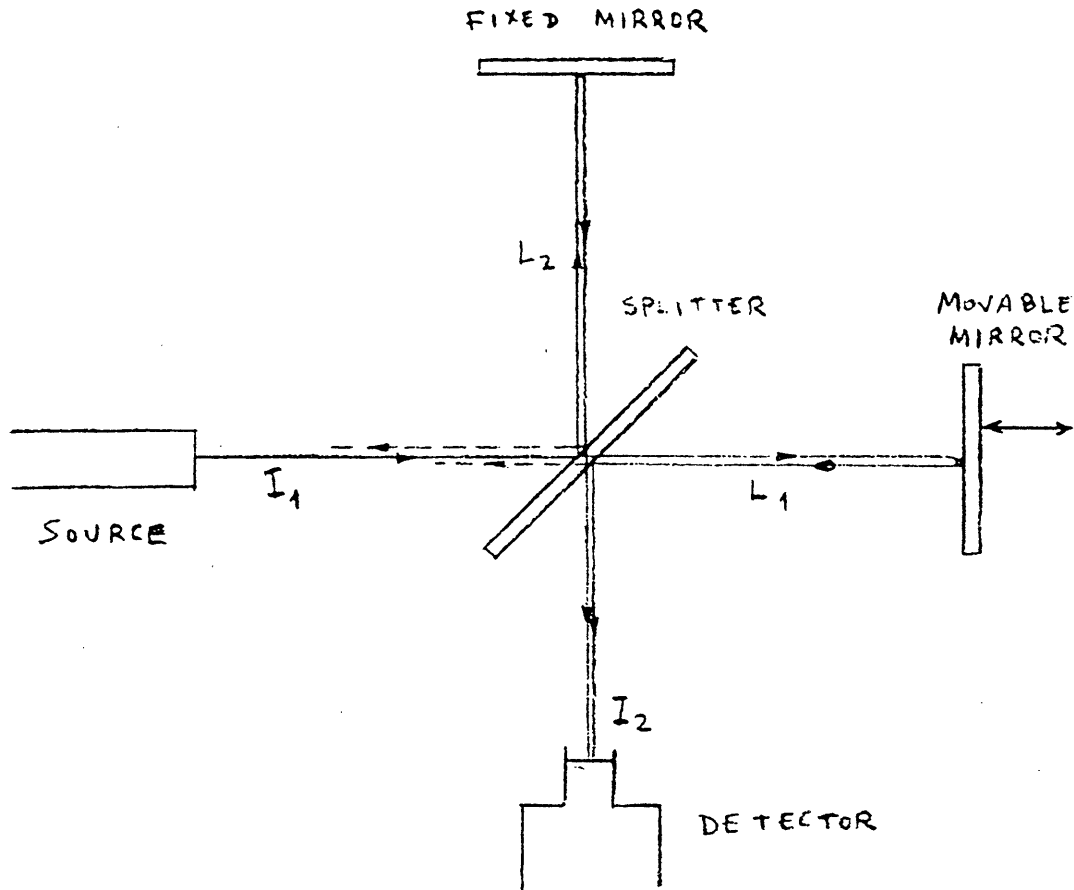

Dynamics
Written Exam Question

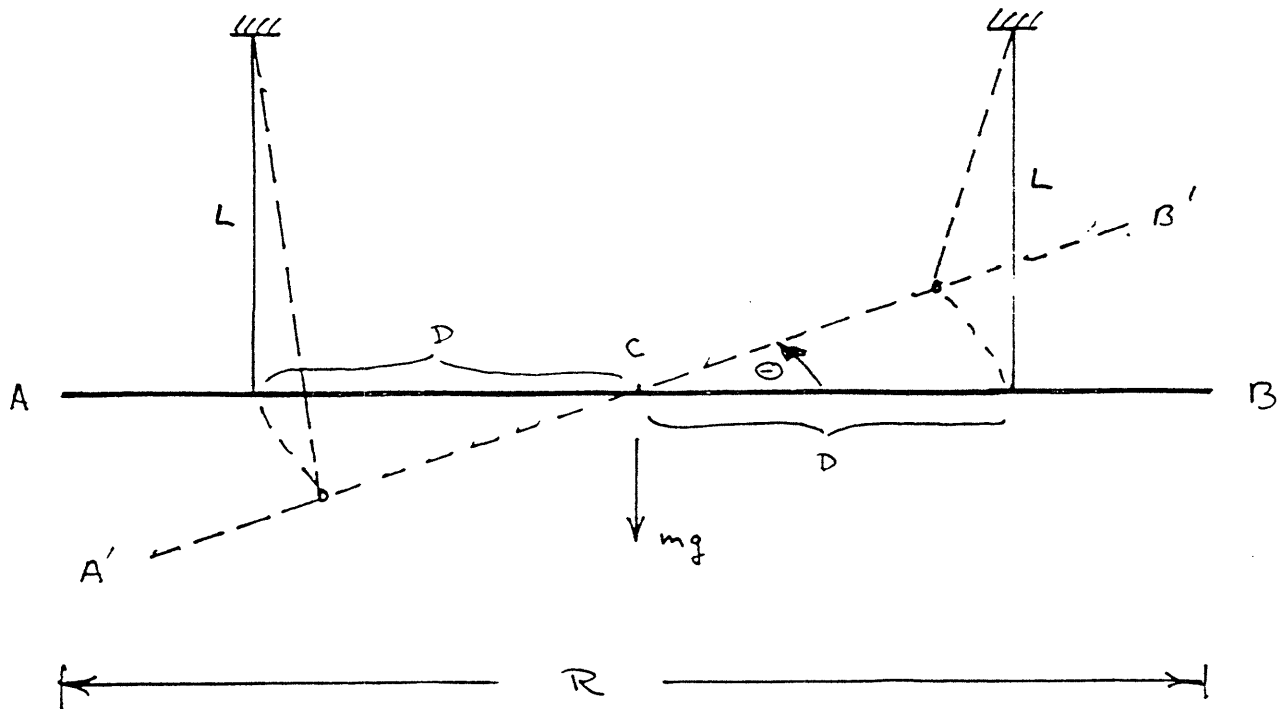

A thin, rigid rod of length, R , and mass, m , is suspended by two vertical strings of length, L , each separated from the bar's center of mass, C , by a distance, D . Obtain the differential equation of motion for small rotations, θ , of the bar in the horizontal about a vertical axis through C . Determine the period of the oscillation and describe how the period would change as the distance, D , is decreased toward zero.

Instrumentation, Guidance, and Control
Written Exam Question

An aircraft is turned by banking, using ailerons as the aerodynamic control. The aircraft dynamics are given by

$$\frac{d^2\phi}{dt^2} = -\frac{1}{\tau_r} \frac{d\phi}{dt} + K_a \delta_a$$

$$\frac{d\psi}{dt} = \frac{g}{v} \phi$$

where

ϕ = bank angle

ψ = heading angle

δ_a = aileron deflection

K_a = aileron control effectiveness

τ_r = roll time constant

g = acceleration due to gravity

v = velocity of aircraft

Use the values

$$\tau_r = 1 \text{ sec}$$

$$v = 400 \text{ ft/sec}$$

When flying by reference to instruments, pilots may use an instrument called a *turn indicator*, which measures yaw rate ($d\psi/dt$), or a *turn coordinator*, which measures a linear combination of yaw rate and roll rate, $y = d\psi/dt + 0.35d\phi/dt$.

(a) The pilot may be modelled as a simple gain control law, K_p , which multiplies either the turn indicator or turn coordinator output to obtain the aileron deflection, δ_a . (The pilot's objective is maintain level flight in a straight line.) Draw the root locus of the poles for each case (turn indicator or coordinator).

(b) Discuss the result above, based on frequency domain arguments. What happens if the pilot is modelled as a gain plus a time delay?

(c) Based on the results of parts (a) and (b), which instrument is preferable for flight by reference to instruments? Why?

Fluids

Written Exam Question

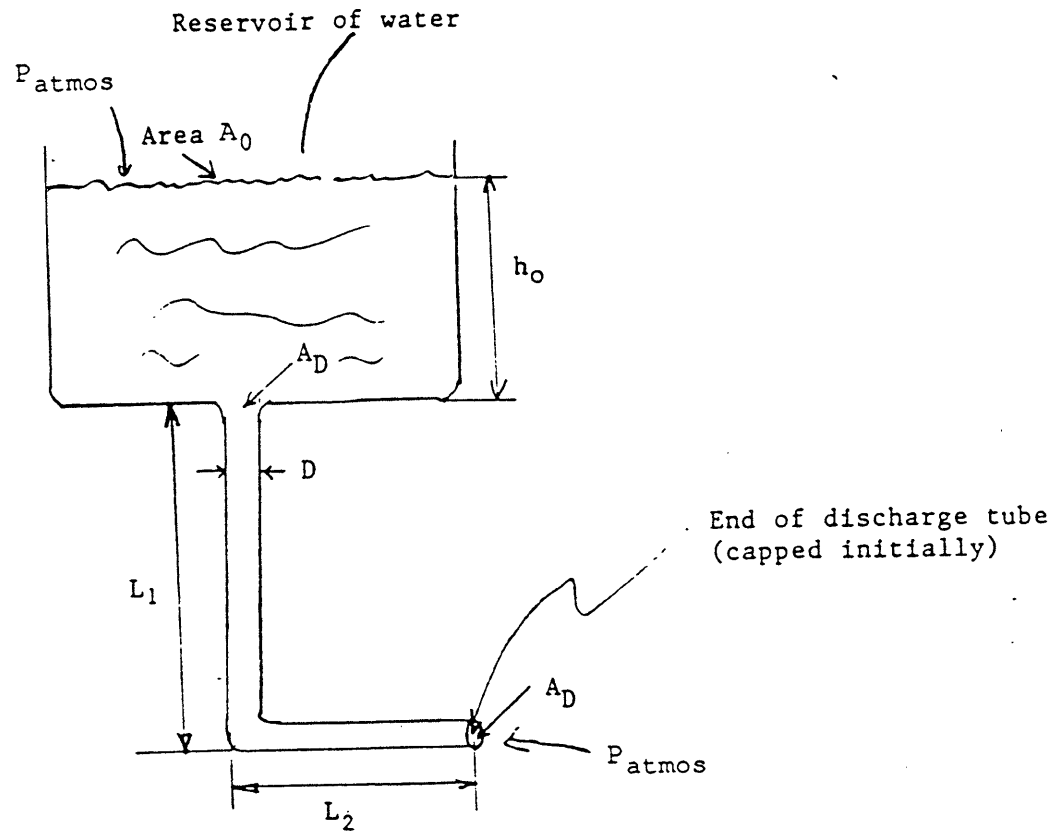

Consider a large reservoir of water, as shown, open to the atmosphere. The open surface has area A_0 , the reservoir has vertical sides, and the initial depth is h_0 .

A small hole of area A_D is provided in the bottom of the reservoir, and a bent discharge tube, with lengths of sides L_1 and L_2 as shown, is fitted. The inner diameter of the tube is D , and the area is A_D , all along its length(s). Assume $(L_1 + L_2)/D \gg 1$, and assume the edges of the hole are rounded.

Initially, the tube is capped at the discharge end.

At time $t=0^+$ the tube is uncapped at the discharge end, i.e., opened to atmosphere.

Fluids

- A) At the first instant of time, $t=0^+$ after the uncapping, what is the acceleration of the fluid in the bent tube?

The time history of the volumetric discharge rate from the reservoir may well look like the following:

$$\dot{Q} = \frac{\text{volume discharged}}{\text{unit time}}$$

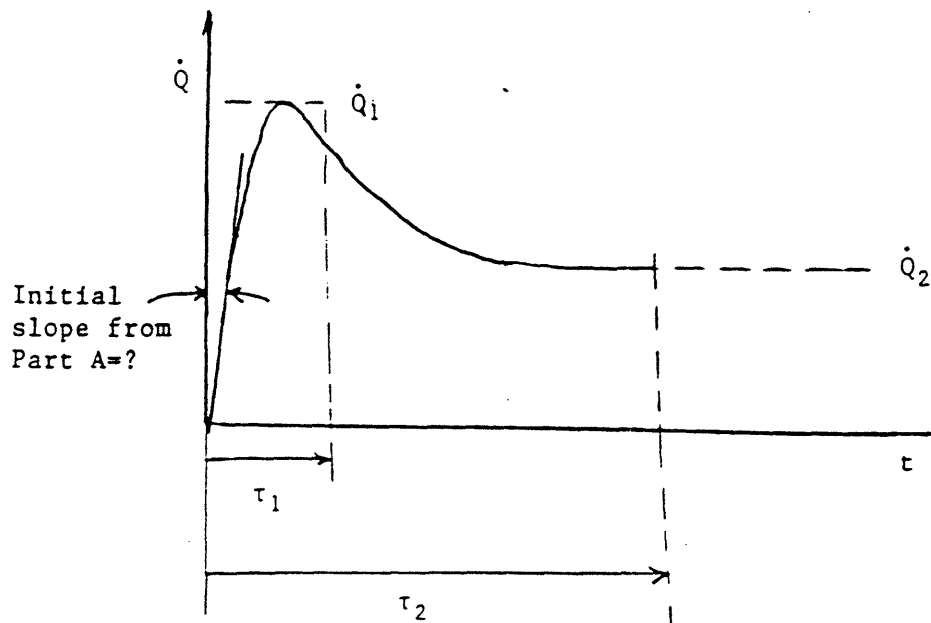

up to the moment the reservoir is finally emptied (i.e., $h_0 \rightarrow 0$).

Here, " τ_1 ", is an "inertial/inviscid" time scale over which pressure gradients and inertial effects tend to balance, whereas " τ_2 " is a time scale after which viscous effects in the discharge tube become important.

- B) Assuming $\tau_2 \gg \tau_1$, identify τ_1 and the peak discharge rate

$$\dot{Q}_1 = ?$$

$$\tau_1 = ?$$

Hint: Your result in part A will help you find τ_1 .

Fluids

- C) Estimate τ_2 . For times comparable with or larger than τ_2 , what do you expect the flow character to be in the tube?

"Fully-developed" laminar flow in a horizontal tube of length L and diameter D can be described by

$$\frac{\Delta p}{LD} = \rho \bar{U}^2 \left\{ \frac{32}{Re_D} \right\} \quad (\text{horizontal tube})$$

where Δp is the pressure drop along the tube, and $Re_D = \frac{\bar{U}D}{\nu}$

and $\bar{U} = \frac{\text{volume flow rate}}{\pi D^2/4}$.

- D) Show how this expression can be generalized in our case to allow calculation of the long-time (asymptotic) discharge rate \dot{Q}_2 .
- E) For water, take $\rho = 10^3 \text{ kg/m}^3$ and $\mu = 10^{-3} \text{ kg/m sec}$. Assume $D = .5 \text{ cm}$, $h_0 = 20 \text{ cm}$, $L_1 = L_2 = 10 \text{ cm}$. Find \dot{Q}_2 in this case and compare with \dot{Q}_1 .

State clearly, throughout, all assumptions or approximations you may use.

Structures

Written Exam Question

A cantilever beam, supported by a cable BC, is loaded by a tip load P as shown below. The cable is pulled snug before the tip load is applied.

- Determine the tension T in the cable after the load P is applied.
- Determine the vertical deflection of the beam tip.
- State the possible failure modes of the cable and of the beam.

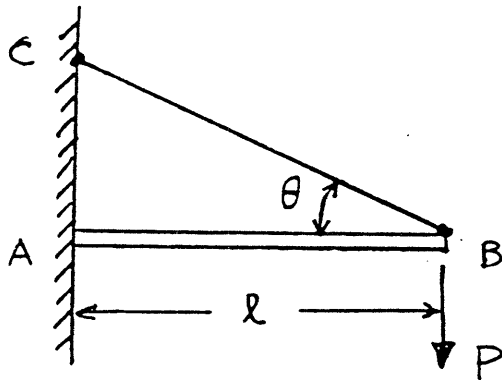

Beam stiffness, EI

Cable Area, A

Beam and cable made of same material.

Propulsion
Written Exam Question

Consider the compressible flow in a rotating channel, such as might be part of a propulsion system (e.g. turbine). The situation is shown below. The angular rotation rate is ω , and the flow is steady and isentropic.

- 1) What quantities, if any, are constant along the flow direction (outward)?
- 2) There is a "throat", i.e. a location of minimum area in the channel, as shown.
 - a) Derive the conditions for choking of the flow if the channel is not rotating.
 - b) Derive the conditions for choking if the channel is rotating at angular rate, ω .

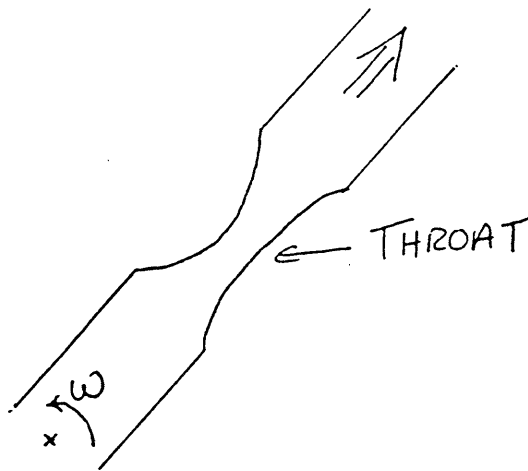

Systems

Written Exam Question

Show the drag coefficient ($C_{D_{TO}}$) sensitivity of the take-off distance (X_{TO}) for an airplane of mass M , at velocity V_{TO} , gross weight W , wing reference area S , rolling friction coefficient μ is

$$\frac{\partial X_{TO}}{\partial C_{D_{TO}}} = \frac{1}{C_{D_{TO}}} \left\{ X_{TO} + \frac{\frac{1}{2} m V_{TO}^2}{T - \mu W - \frac{1}{2} \rho V_{TO}^2 S C_{D_{TO}}} \right\}$$

Explain the significance of the several terms.

Thermodynamics
Written Exam Question

In working out this problem explain and justify in physical or mathematical terms every step in your answer.

The cylindrical compartment shown in the **sketch A** below is separated by a partition into two equal volumes, one contains an ideal gas, the other is evacuated.

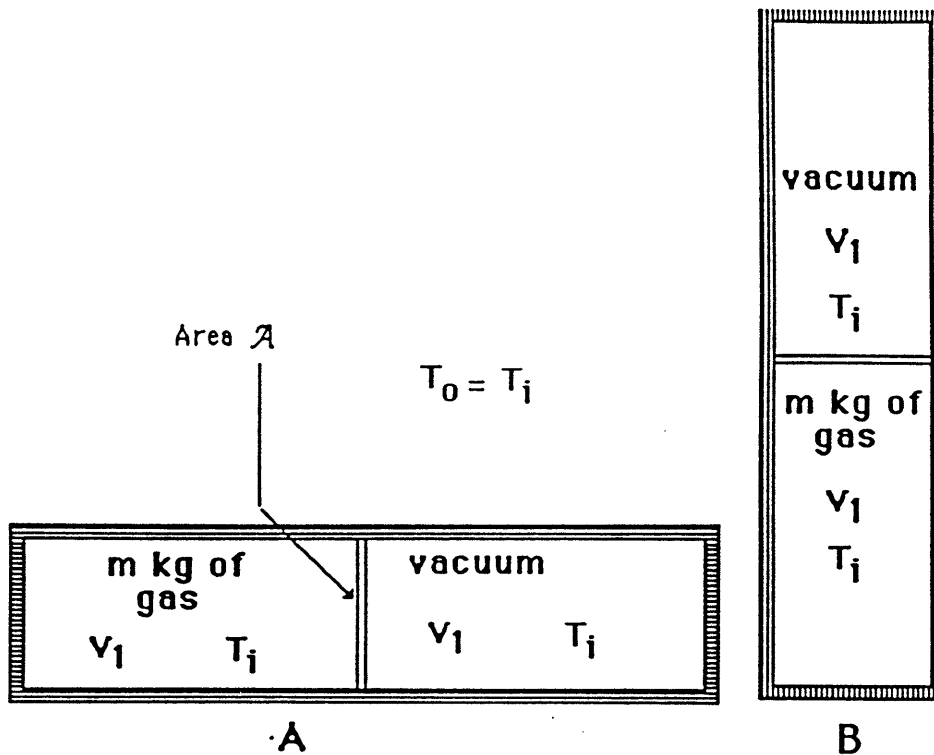

I. Suppose the partition is removed with the compartment in position A. In terms of the properties cited in the figure

a. write expressions for the heat flow, the internal energy change and entropy change for the case where the process is isothermal.

b. write an expression for the internal energy change and entropy change for the case where the process is adiabatic.

Thermodynamics

II. Suppose the cylinder is long enough so that when it is stood up on edge, as indicated in **sketch B**, gravitational effects become important. For the case where the partition is removed with the cylinder in this position write expressions for,

a. the work done and internal energy change when the process is isothermal.

b. the change in temperature when the process is adiabatic

c. the entropy changes in

i. the isothermal case

ii. the adiabatic case

Avionics

Written Exam Question

A typical light aircraft autopilot uses a rate gyro and a directional gyro to maintain commanded heading, ψ_{COMM} . The autopilot can be reasonably described by the following signal-flow diagram.

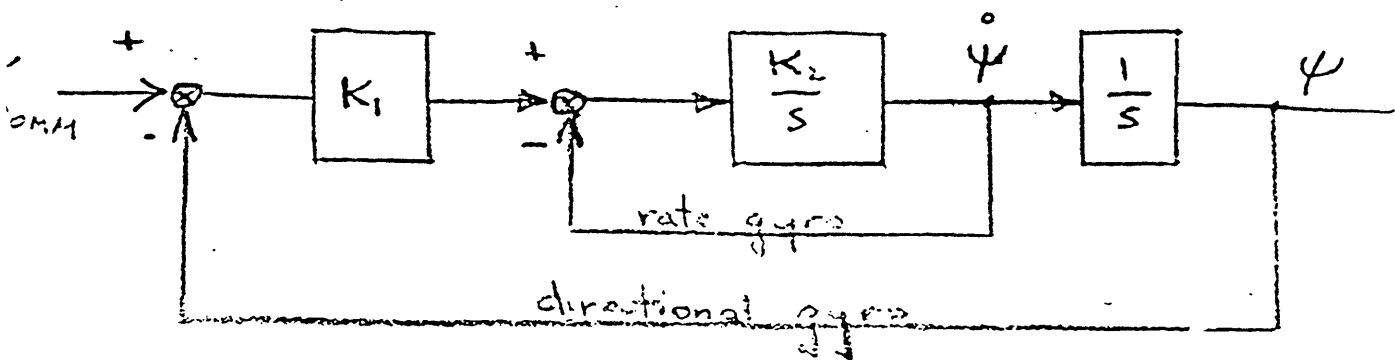

- What are the natural frequency and damping ratio for this autopilot?
- What guidance logic would you add to this autopilot to make it track a desired path assuming you are given the lateral deviation from the desired path by a navigation system?
- What will be the sensitivity of your guidance scheme to wind?
- What is the sensitivity of your system to errors in the measurement of heading and position?
- How would you pick the numerical value of the gains K_1 and K_2 ?

Bioengineering
Written Exam Question

Assume that a pilot can be modelled as follows:

$$Y_p = K_p e^{-j\omega\tau_e} \frac{(1+T_I s)}{(1+T_1 s)}$$

The pilot has the task of commanding continuous control of yaw attitude of a spacecraft during a docking maneuver. The pilot can see the other vehicle's docking adaptor out his window. The system dynamics relating joy stick deflection to vehicle yaw angle are given by either:

$Y_{C1} = 10/s$
or $Y_{C2} = 5/s^2$

Tests of the closed loop tracking system for both sets of dynamics are carried out, on the ground, both fixed based and in a yaw moving base simulator. The RMS error, for an input consisting of a band limited (up to .2Hz) motion of the target vehicle, is given by the following table:

	$Y_{C1} = K/s$	$Y_{C2} = K/s^2$
Fixed Base	2 deg	4 deg
Moving Base	2 deg	3 deg

- A. Explain the different RMS error findings
- B. How do the pilot model parameters vary for the four cases?
- C. What role is played by the vestibular system on the ground and in space?

