

an update

- **Introduction**
- **Progress on the experiment**
- **Schedule**



Arizona State University, USA

DESY, Hamburg, Germany

Hampton University, USA

INFN, Bari, Italy

INFN, Ferrara, Italy

INFN, Rome, Italy

Massachusetts Institute of Technology, USA

Petersburg Nuclear Physics Institute, Russia

Universität Bonn, Germany

University of Colorado, USA

University of Glasgow, United Kingdom

University of Kentucky, USA

Universität Mainz, Germany

University of New Hampshire, USA

Yerevan Physics Institute, Armenia

Lepton-proton elastic scattering cross-section

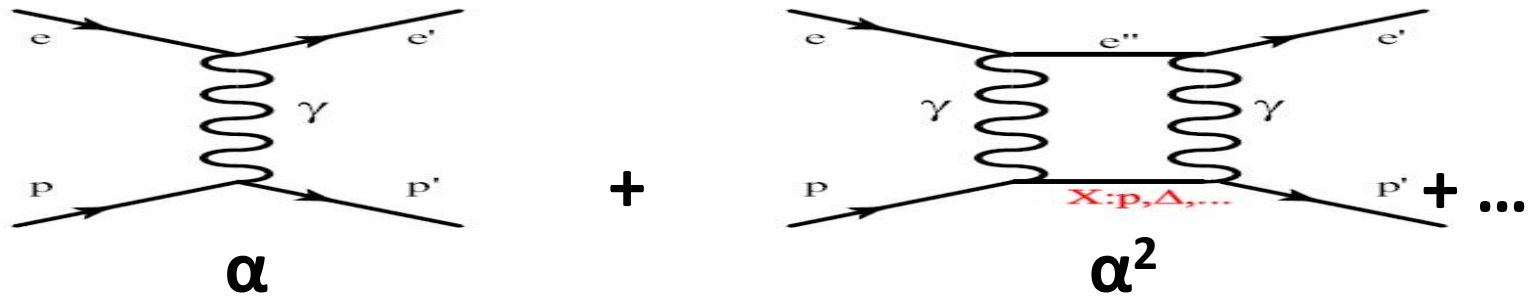

$$\sigma = (1\gamma)^2\alpha^2 + (1\gamma)(2\gamma)\alpha^3 + \dots$$

$$e^- \iff e^+ \Rightarrow \alpha \iff -\alpha$$

$$\sigma(\text{electron-proton}) = (1\gamma)^2\alpha^2 - (1\gamma)(2\gamma)\alpha^3 + ..$$

$$\sigma(\text{positron-proton}) = (1\gamma)^2\alpha^2 + (1\gamma)(2\gamma)\alpha^3 + ..$$

$$\frac{\sigma(e^+p)}{\sigma(e^-p)} = 1 + (2\alpha)\frac{2\gamma}{1\gamma}$$

e^+p/e^-p cross section ratio

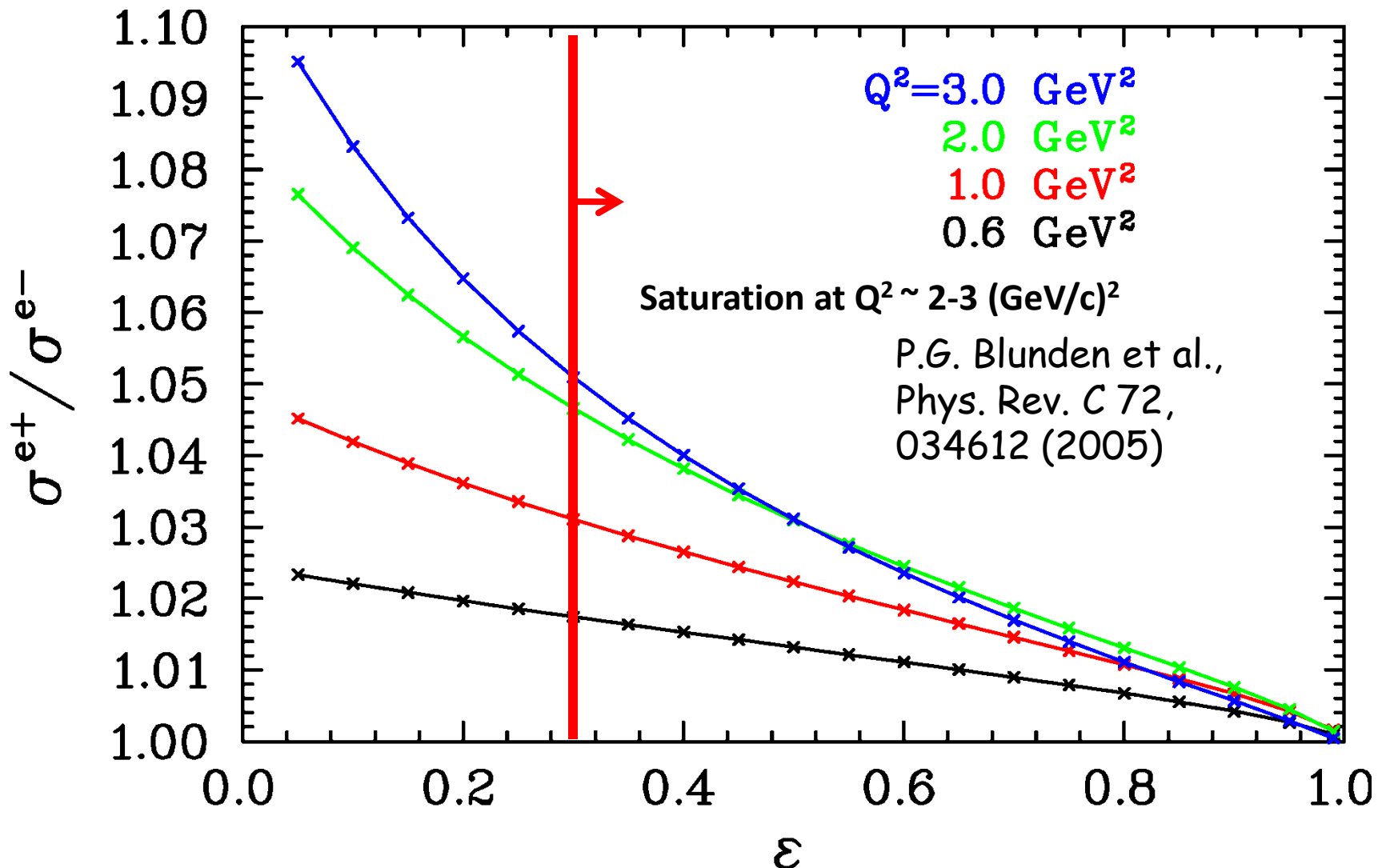

Projected OLYMPUS uncertainties

- Luminosity = $2 \times 10^{33} \text{ cm}^{-2} \text{ s}^{-1}$
- 500 hours each for e^+ and e^-
- 2 GeV energy

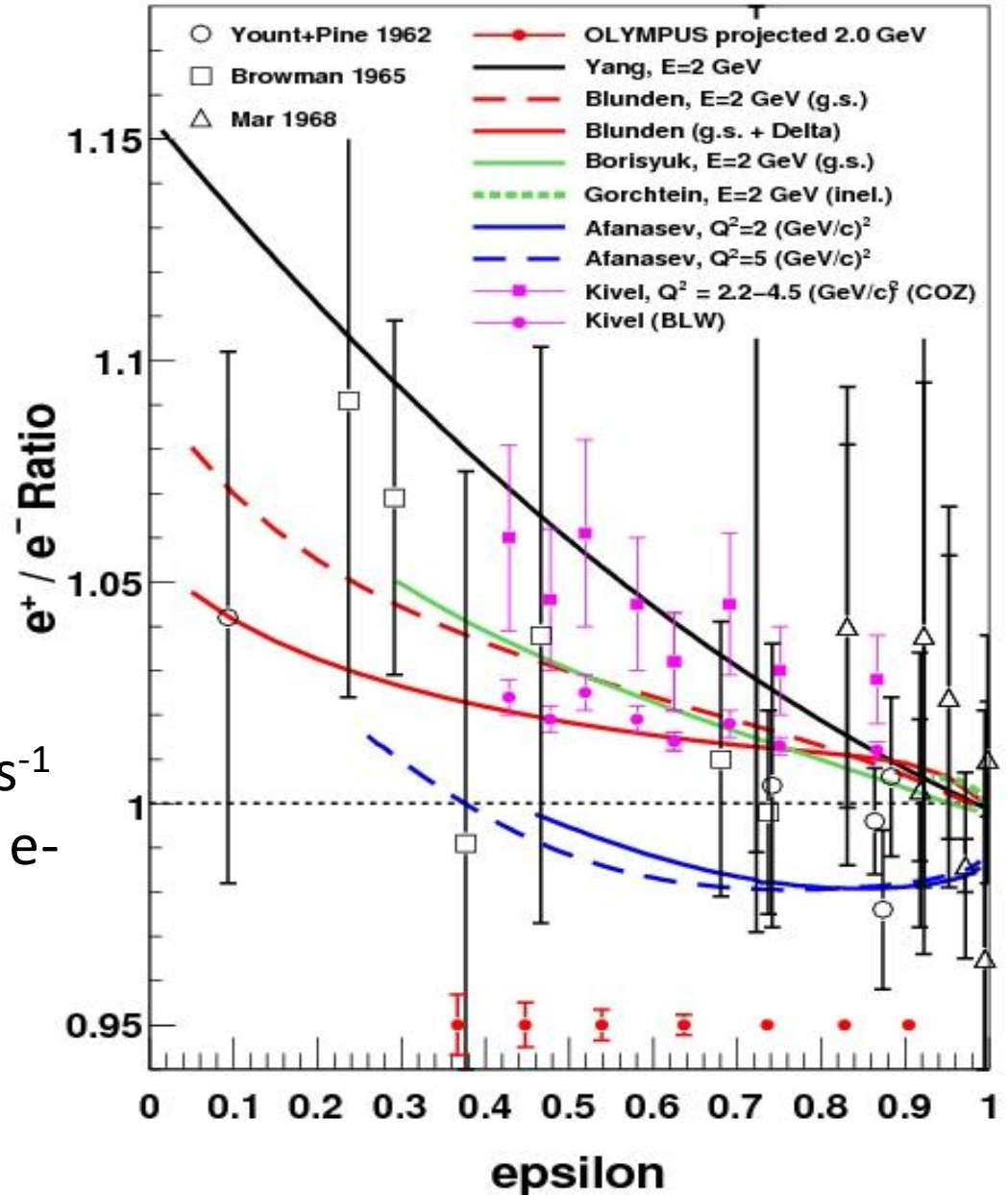

OLYMPUS experiment

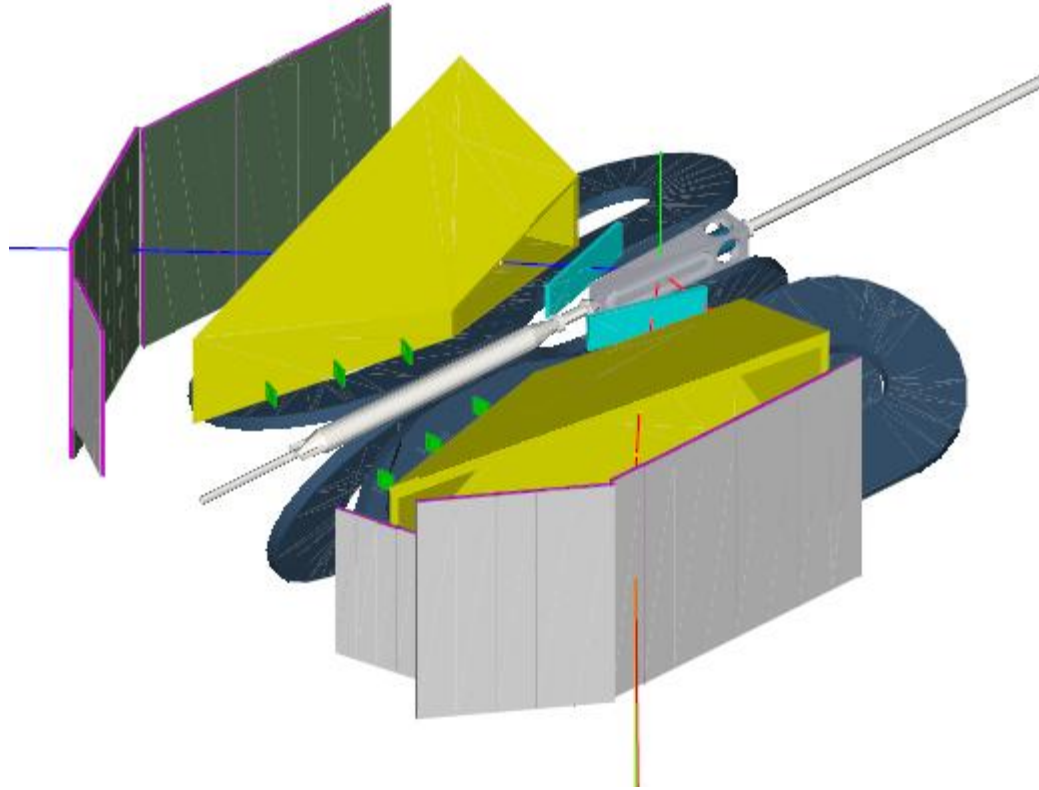

- Use the existing BLAST detector with 100 mA e-/e+ beams of DORIS incident on an internal hydrogen gas target to precisely measure the e^+p/e^-p cross section ratio
- Capitalizes on > \$ 5 M previous investments

Installing Transformer



Progress in DORIS Hall



Progress in DORIS Hall

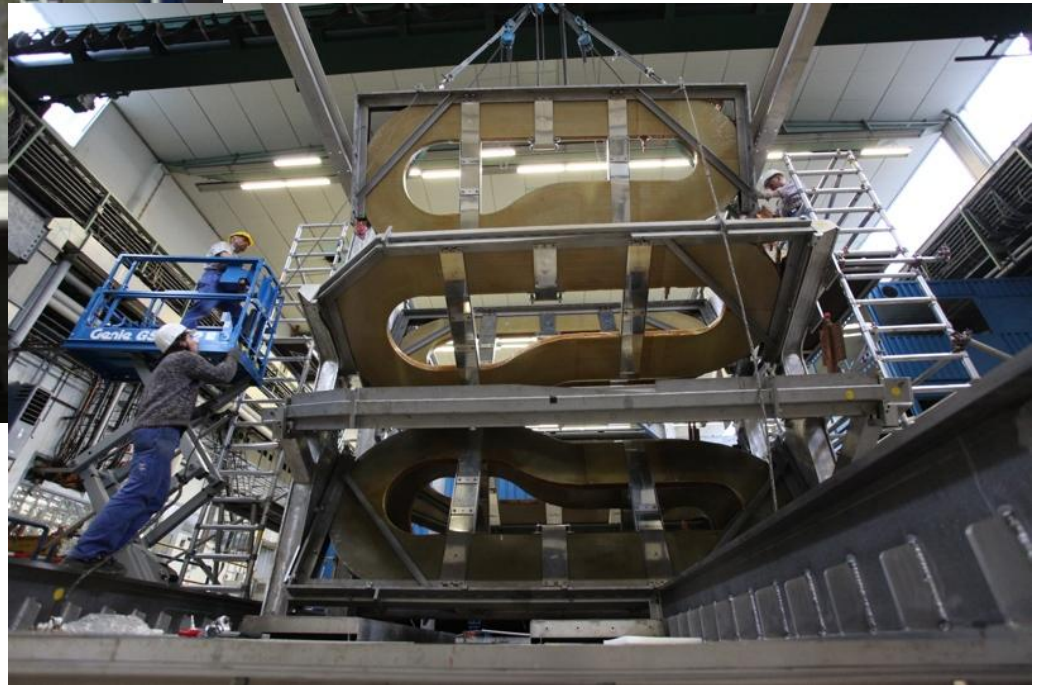

Progress in DORIS Hall

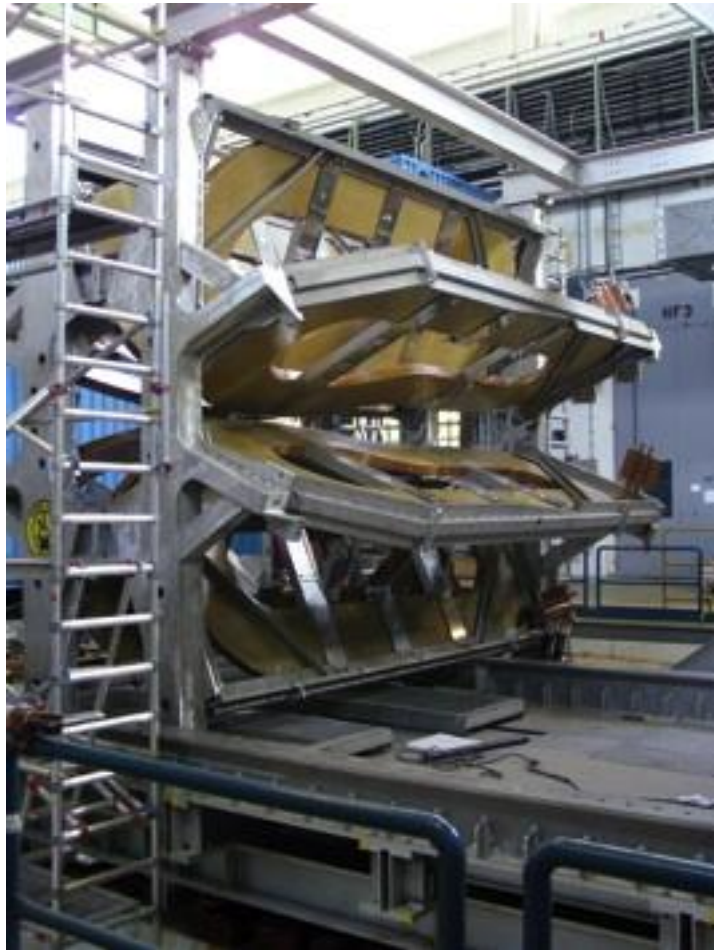

Progress in DORIS Hall

- Outer frames assembled and moved to pit
- Rollers installed
- All coils installed
- Preliminary survey all lower four coils
- Magnet power distribution ready
 - Transformer installed
 - Power supply installed
 - Power cables installed
 - Interconnection of coils to be made
 - Interlock system in preparation
- Water cooling connections is progress
- Some rollers are being moved (guiding rollers)
- All TOF counters tested and repaired when necessary
- Sub-detector frames assembled
- Tasks after installation of guiding rollers
 - Survey and adjustment of coil positions
 - Commission power magnet and magnet
 - Perform field measurement
 - Re-align coil positions if necessary

OLYMPUS Wire Chambers

Shipped from MIT-Bates to DESY June, 2010

Clean room in former TASSO experimental hall

Re-wired wire chambers July-August, 2010

New HV distribution boards being prepared at MIT-Bates

Plan:

- connect HV distribution boards to wire chambers in January, 2011
- final test of wiring for continuity, opens, and shorts
- move to DORIS hall February, 2011
- connect gas manifolds, flush with gas, and test with HV
- install into sub-detector frames, align, and survey March, 2011
- commission in park position with DAQ chain and magnetic field

Wire Chambers in Clean Room



Wire Chambers

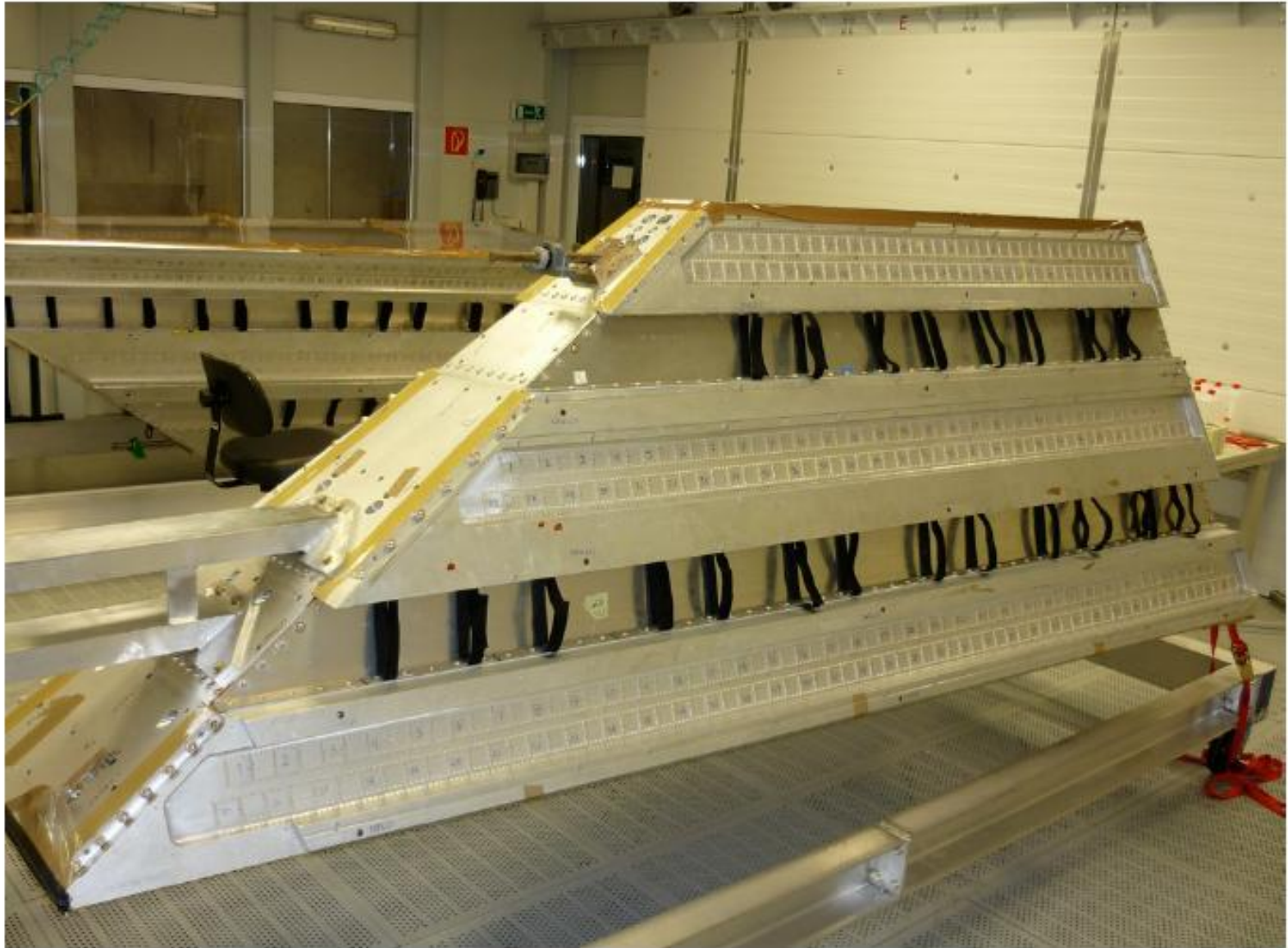

Wire Chambers

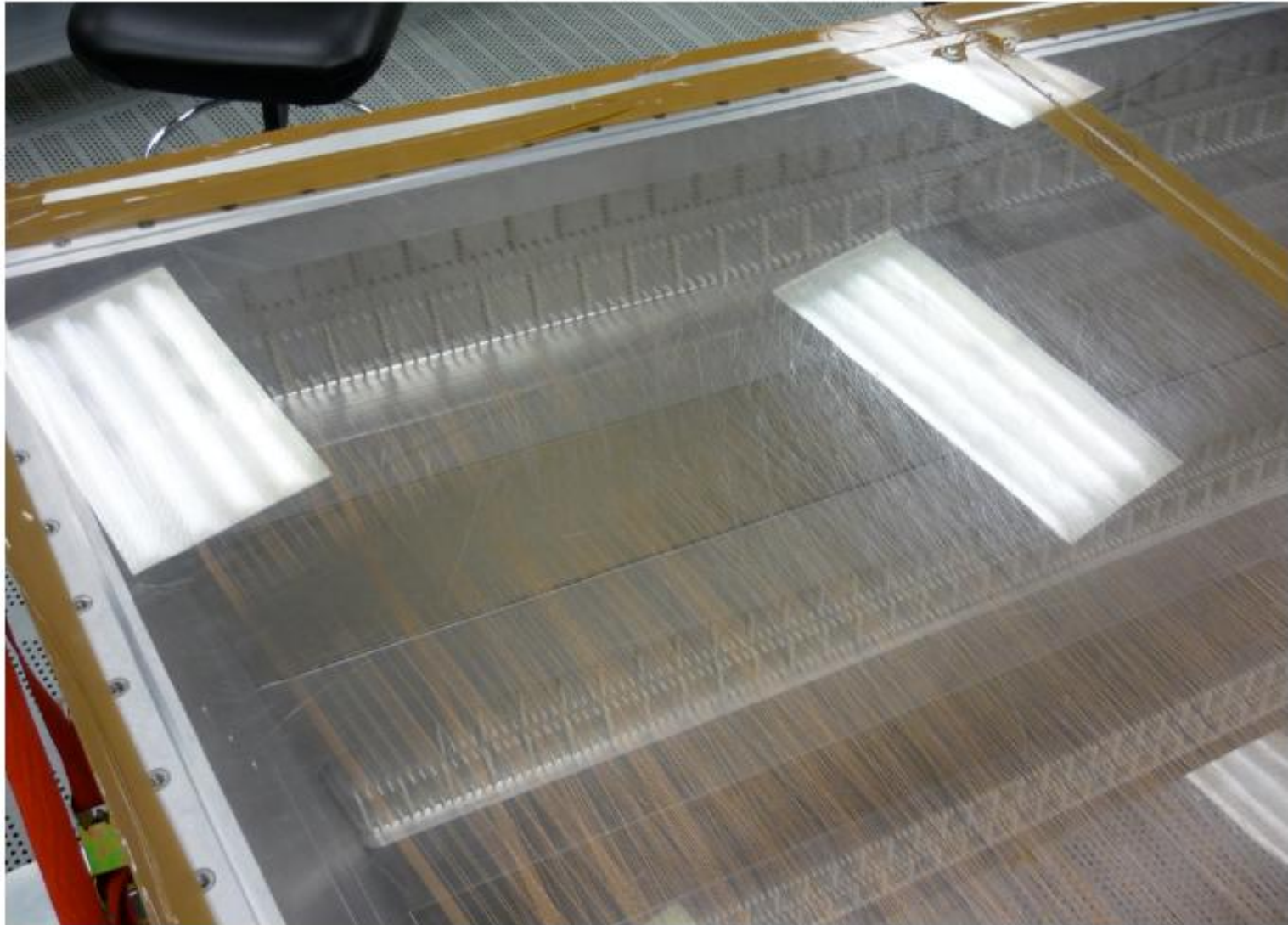

TOF Status

- On the bench
 - 8 small TOFs (1 re-glued)
 - 24 large TOFs (8 re-glued)
 - 8 Bats: (4 require back bones)
 - 5 full spare modules (3 rely on exchange back bone)



TOF Calibration

- Each counter to be calibrated individually
 - Efficiency measurement: top, middle, bottom
 - 25 done, resulting efficiency $>99.7\%$
 - Includes check of whole system
 - hidden light leaks + repair
 - optimising plateau voltage

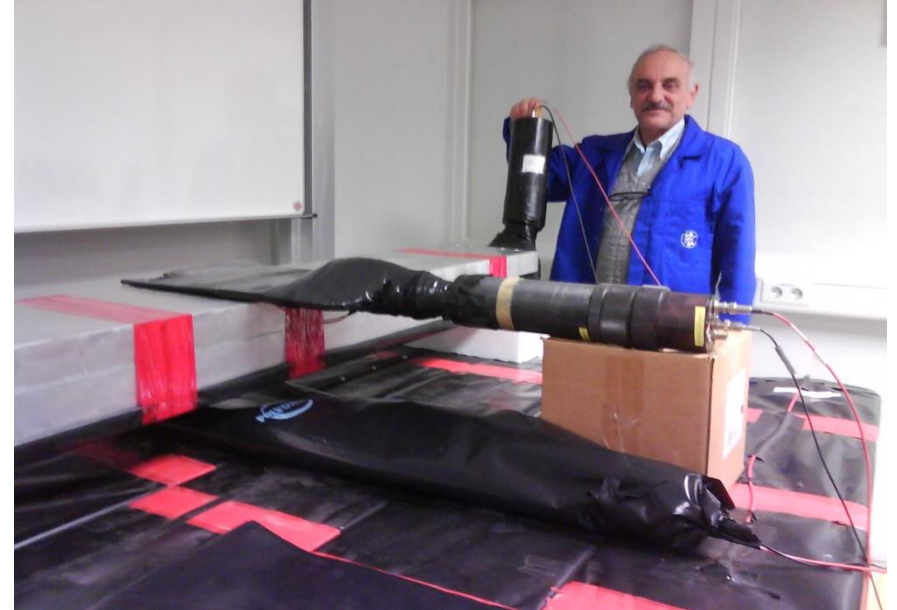

- Vladislav Yeganov
- Michel Zhamkochyan

TOF Support Structures

- Manufacturing started

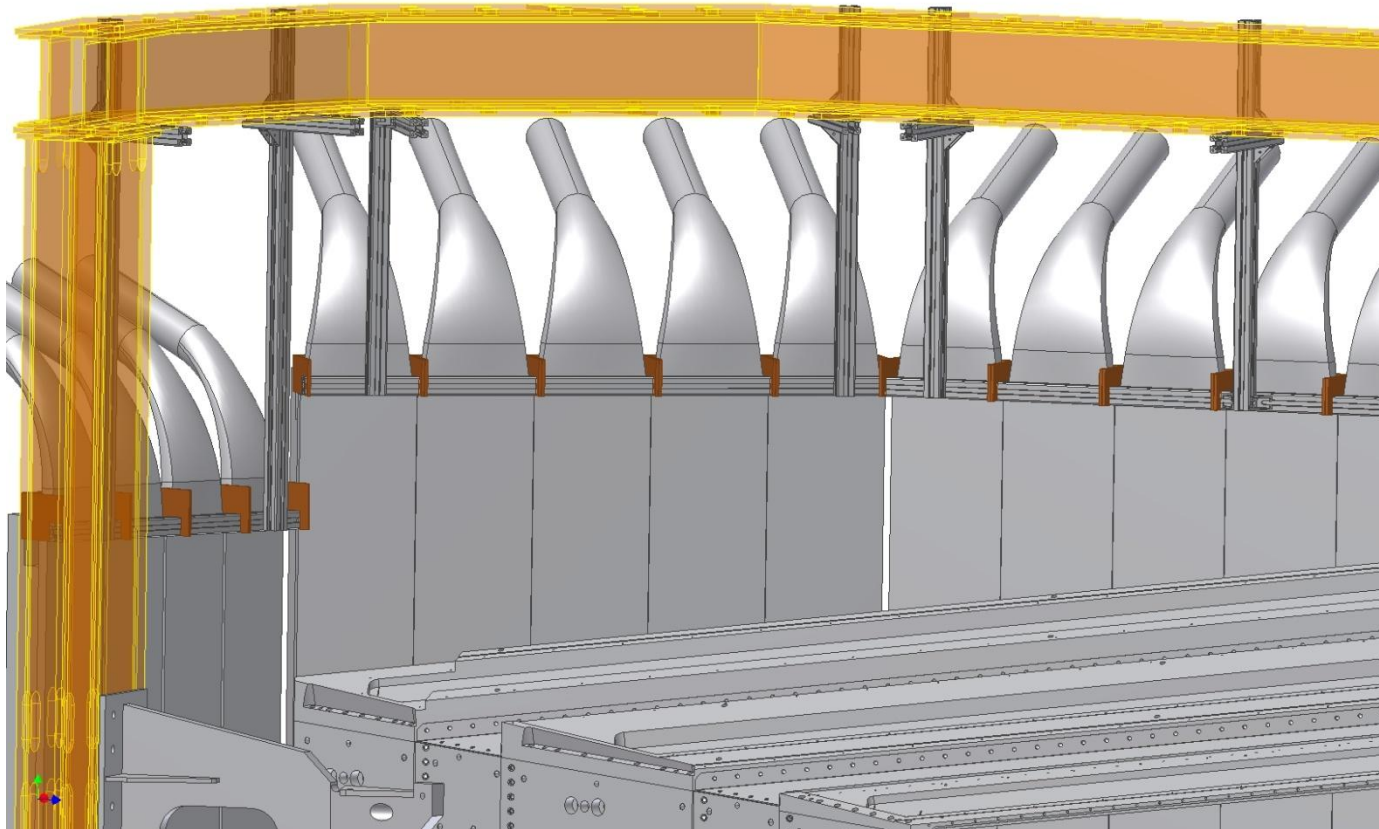
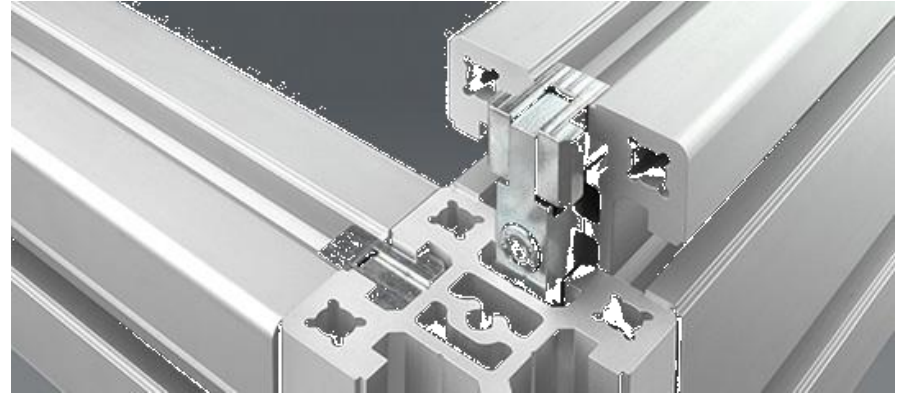

TOF Light flasher

- Rise time

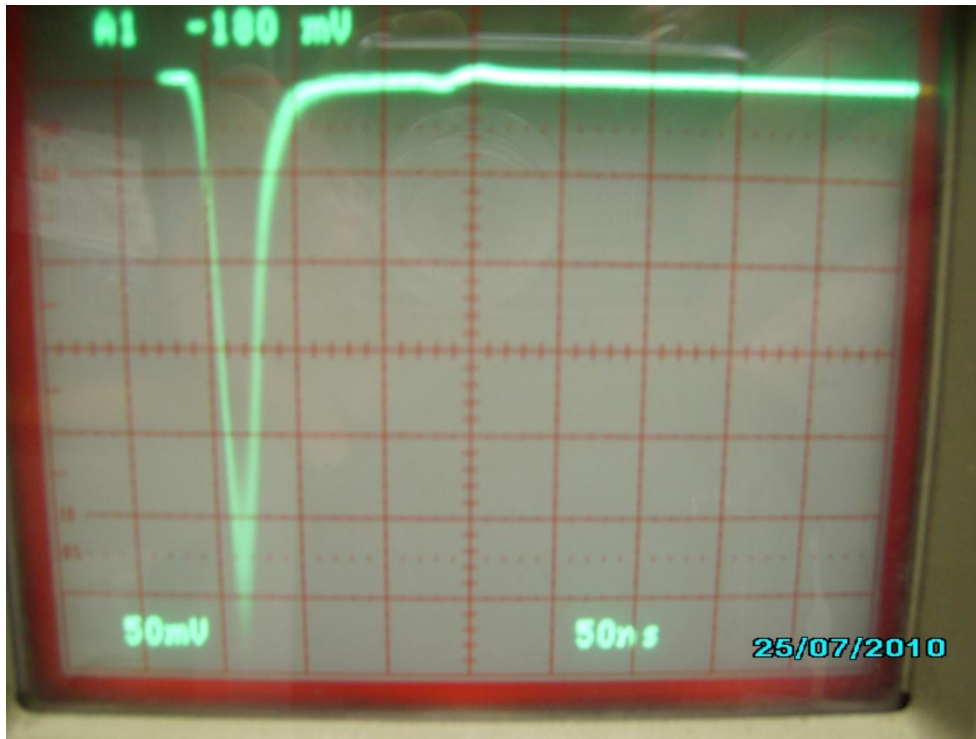

- Fibre preparation time demanding

- Henrik Vardanyan
- Juergen Diefenbach

- Installation scheme

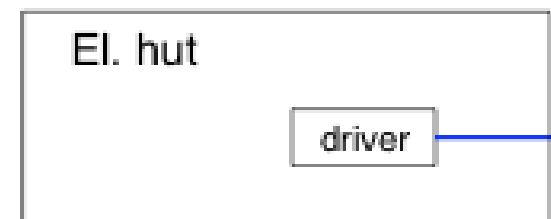
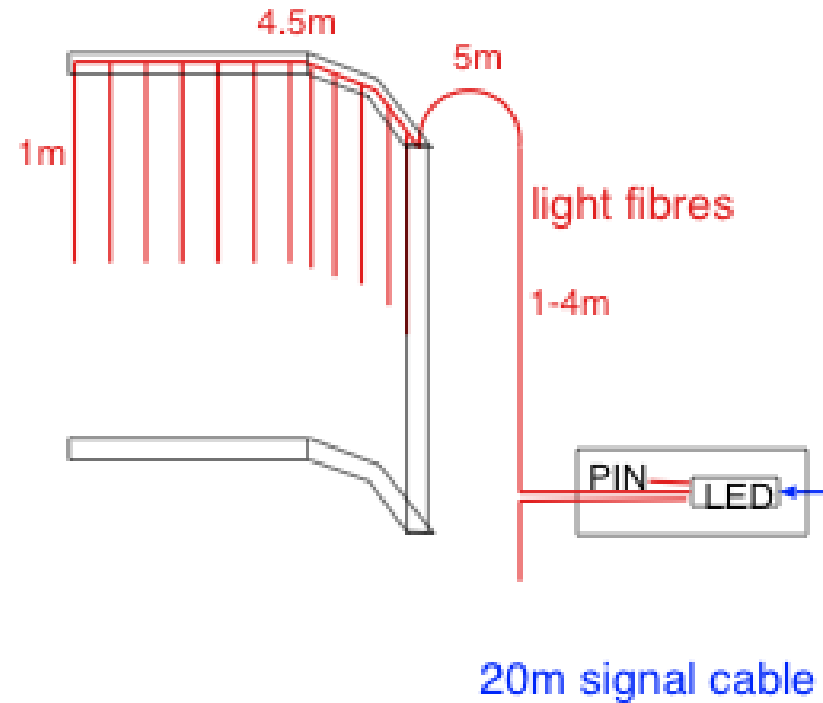

12-degree Lumi monitor MWPCs

- chambers included in OLYMPUS GEANT4 & CAD databases and fiducialized
- anode/cathode planes are in production
- complete set of drawings by end October
- fabrication and tests in November
- two chambers for test run will be shipped to DESY in December

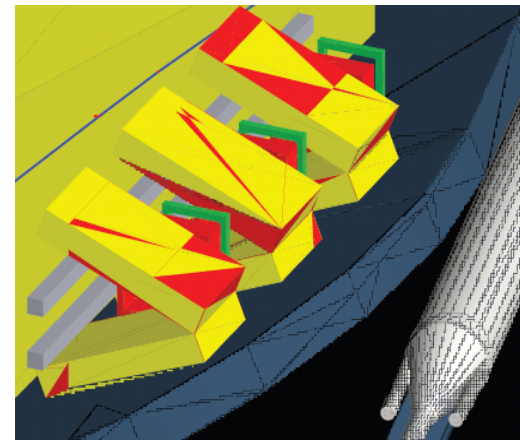
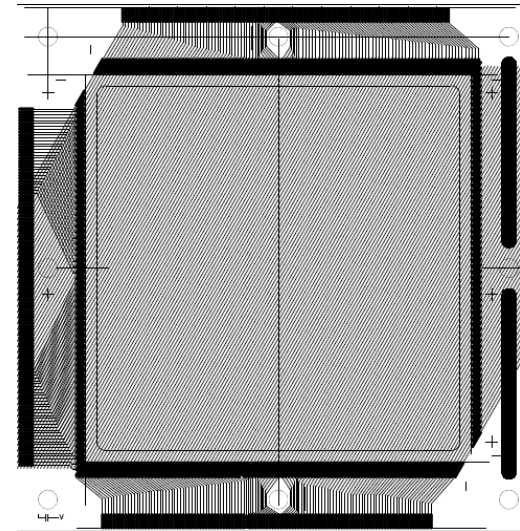
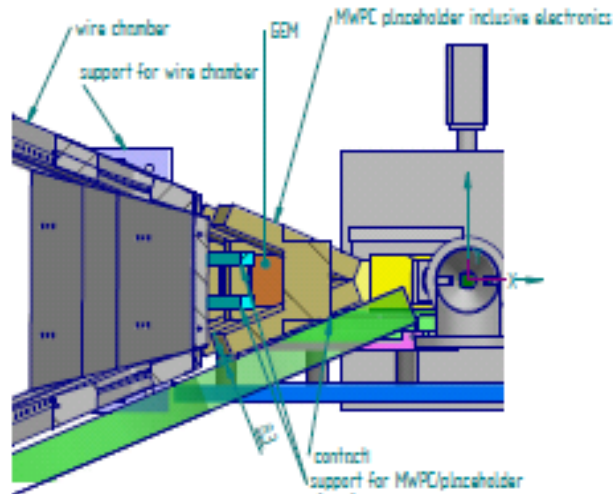
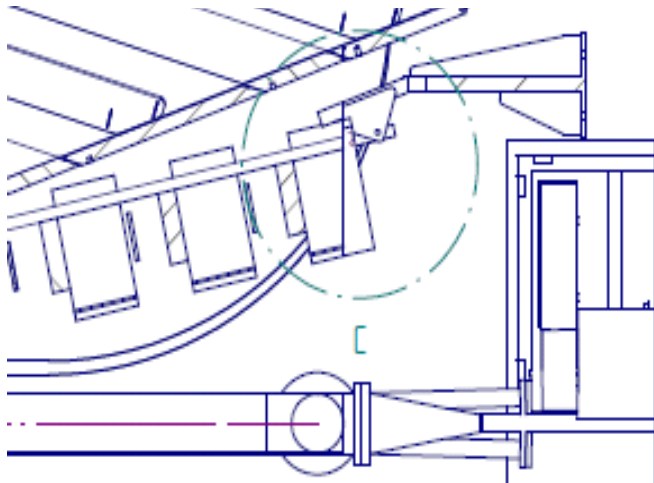

Tasks & Timeline for LuMo Construction

GEM Construction	01/2010	01/2011	01/2012	12/2012
Finalize design	██████████			
Purchase of GEM parts		██████████		
Assembly at MIT		██████████		
Tests with cosmics at HU			██████████	
Tests with beam			██████████	
Transfer to DESY			██████████	
Pre-install at DORIS				██████████
Commissioning w/ beam			██████████	
Install w/ main detector				██████████
Final commissioning				██████████
Production running				██████████

Table 4: Work plan for GEM luminosity monitor construction activities.

- Experiencing some delays, yet keep goal of providing GEMs by end of 2010
- Frame preparation and cleaning completed
- Assessment of GEM foil quality (Optical scanning; HV testing & conditioning)
Gluing of gas pressure foils, HV foils, GEM foils partially completed
- Assembly of GEM detectors in progress - three elements by Dec. 2010, remaining elements by March 2011
- Testing at DESY in winter and spring 2011
- Final installation in OLYMPUS main detector in spring / summer 2011

Preparation of GEM detector system

- Established one complete GEM2D box
- Test readout board with 2mm pitch designed and delivered July 2010
- Adapters to connect test board with INFN APV frontend designed (Sep. 2010)
- Final readout board (400 μm pitch) for LuMo designed, quote requested
- Electronics equipment (VME 64x crate, CPU, HV supplies) purchase orders prepared (October 2010)
- Support structure for array of GEMs and MWPCs designed (September 2010)
Fitting of telescope array into available spaces in 3D CAD

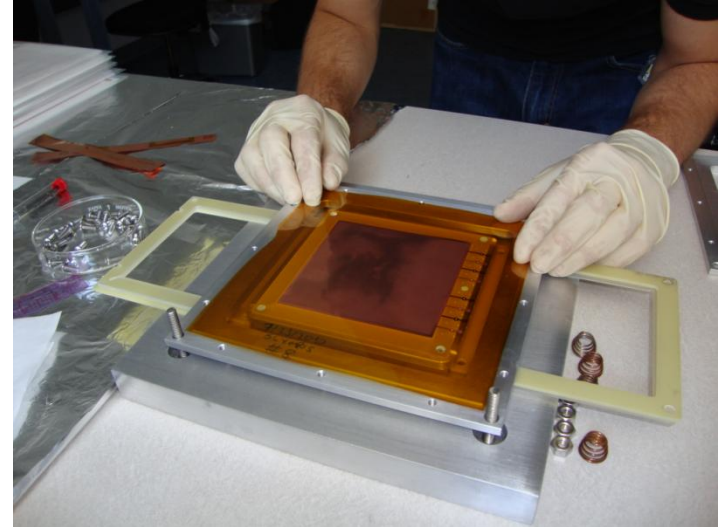

Electronics tests

- Complete system assembled during test beam at DESY last July.
- Communications between FEC, VME and PC worked but not optimized (acquisition rate improved in September work at lab).
- Noise problems to be cured (mismatching impedance, FEC designed for bigger chambers, input capacitance to be adapted, work underway)
- Full test underway at lab.
- Next test beam at DESY in November.

OLYMPUS GEM Tracker

GEM tracker

- large area triple GEM detector between target chamber and wire chambers in each sector
- augments tracking by providing a fourth space point
- simplifies track reconstruction as tracks curve very little between target and first wire chamber allowing a simple straight line fit

Status

- design underway
- Colton O'Connor optimising position and dimensions using GEANT4
- Jason Bessuille working on mechanical design
- front-end electronics will use APV chips similar to STAR FGT
- readout will use the readout system developed at Bonn

Symmetric Moller/Bhabha Lumi Monitor

- Two Arrays of PbF_2 crystals with PMT at small scattering angles
- Location: Between BLAST coils and beam line quadrupole
 - => Tight space limitations
 - => Careful consideration of magnetic fringe fields

New Magnetic Simulations

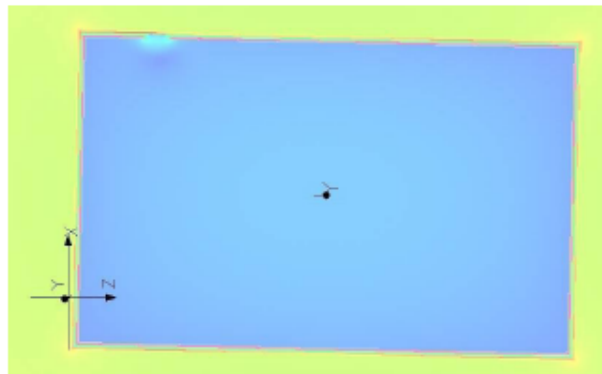

Field Inside the Box < 0,01 Gauss:
More than OK

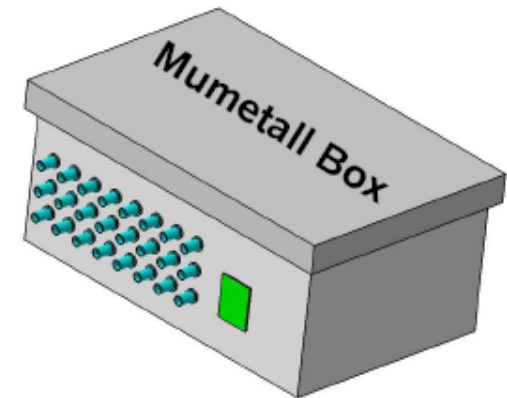
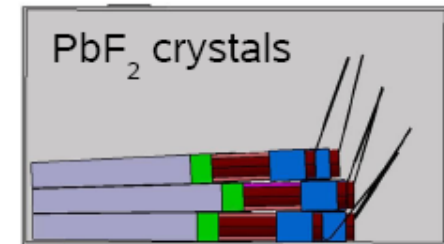

Installation into beamline

- Mechanical design finished
- Parts are in the Institute's workshop

Distance to beam is adjustable

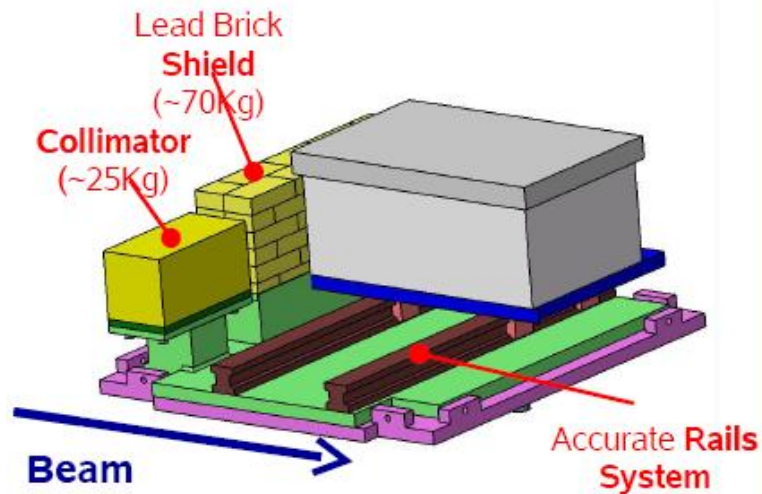

Setup in the beam line

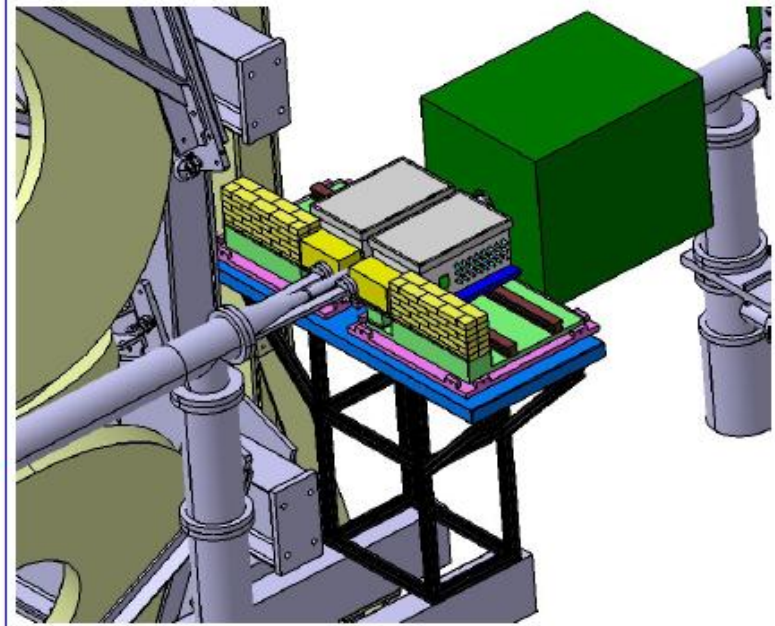

Optimization of collimator design

- Example: Energy deposit inside PbF₂ crystals from Moeller/Bhaba events for a certain collimator thickness/diameter

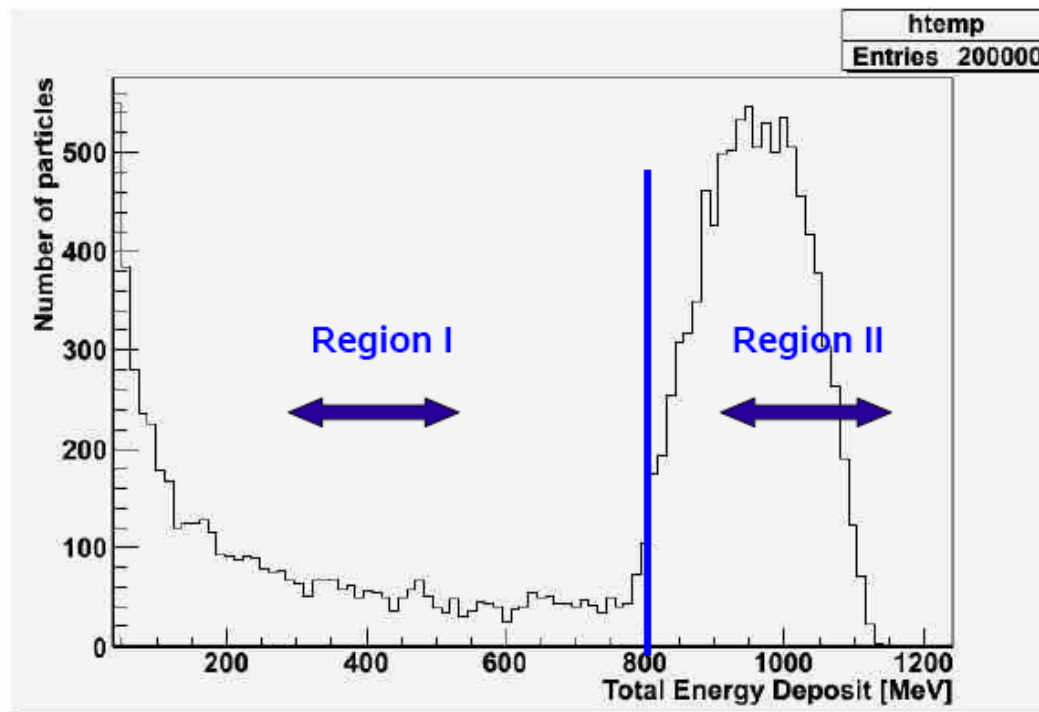

- Peak width dominated by energy spread of Moeller/Bhaba events over the detector acceptance

Data acquisition principle

DAQ-unit:

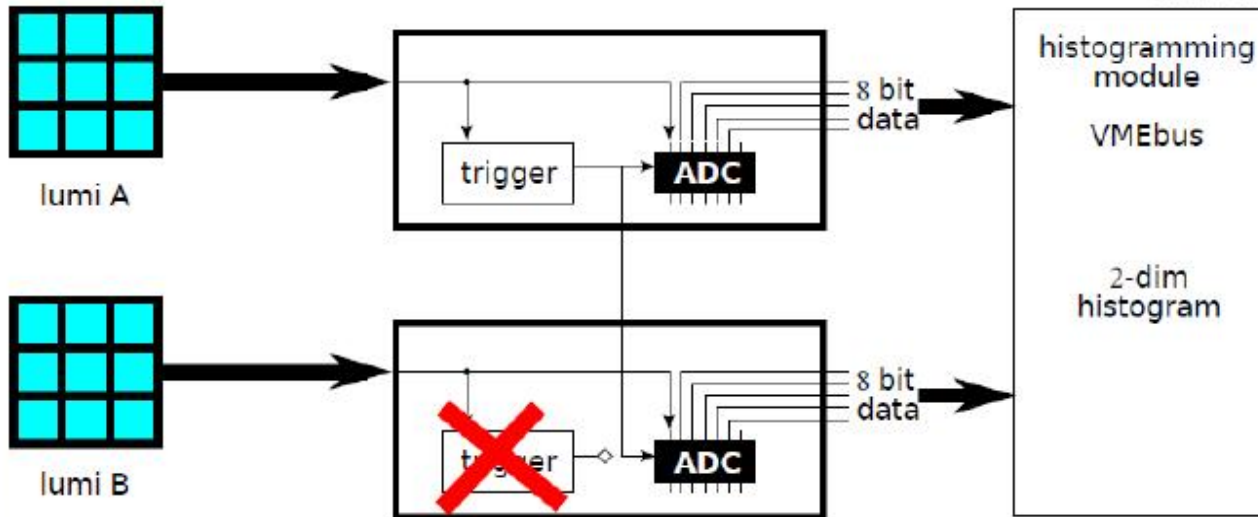

Three types of triggers:

- Trigger on Lumi A
- Trigger on Lumi B
- Trigger on Lumi A&B



Target chamber

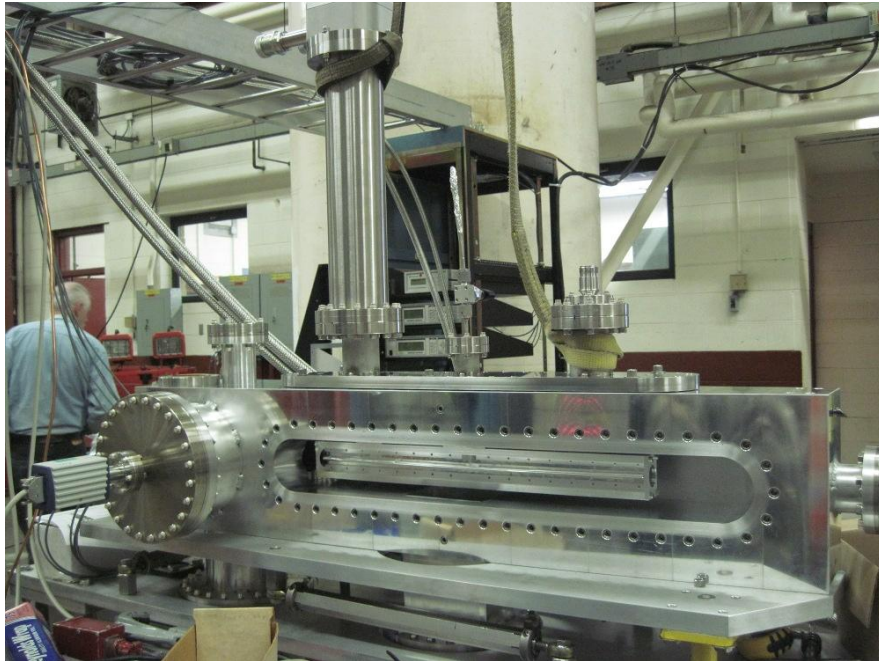

- Target cell installed and aligned
- Cold-head installed
- Pumps and controllers connected
- Vacuum gauges connected



Vacuum system

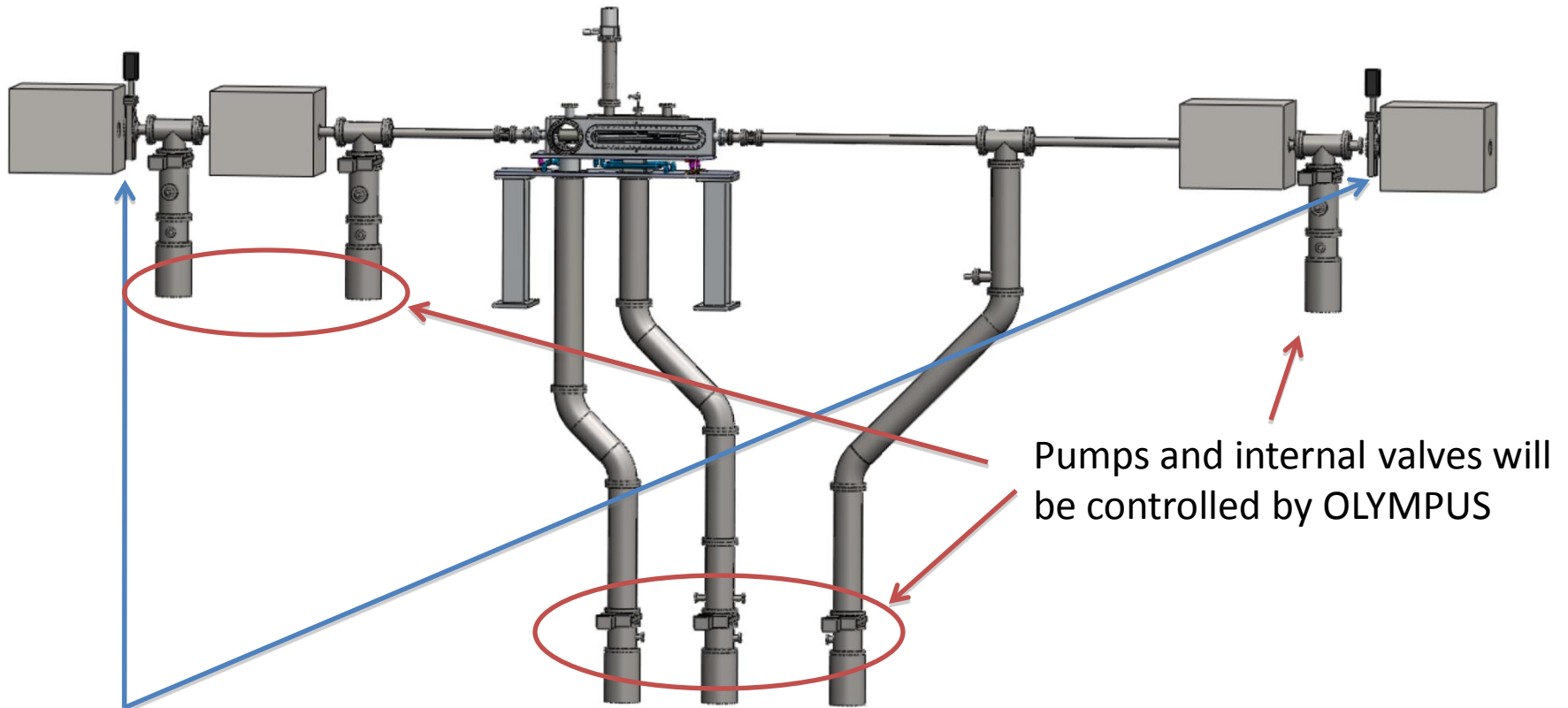

Pumps and internal valves will be controlled by OLYMPUS

DESY integration:
Will be new vacuum segment.
Valves controlled by DESY vacuum group.

Gas System

Status of hardware:

- Main part of system operational
- Buffer system in progress

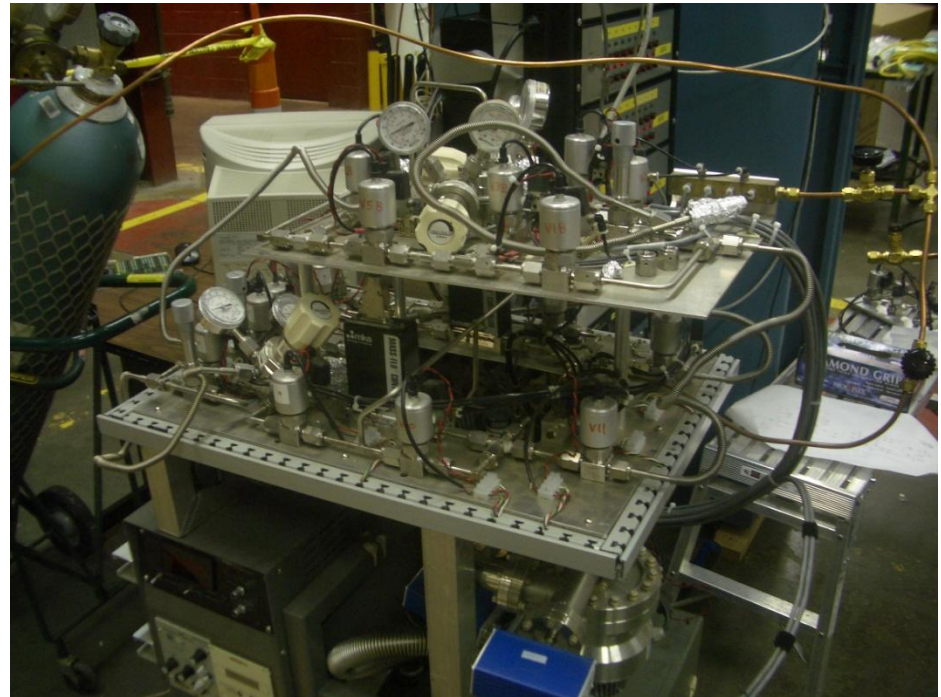

Status of slow control:

- Original software solution ported to new OS, operational
- Rewrite of backend and GUI started
- VME Drivers working
- Write new drivers for vacuum gauges (added functionality)

Data acquisition system

Hardware Status

- 4 VME CPUs available
- 1st storage/devel server installed
- Sync system installed and operational
- Main trigger installed and operational



Software Status

- Implemented standard system for VME-CPU's
- Setup runcontrol and readout environment
- Setup Onlinemonitor
- TOF ADCs and TDCs (Fastbus) working



Infrastructure Status

- Network in the electronics hut is up and running
- All non-OLYMPUS material was moved out of the hut (Bonn students)
- All available modules will be tested (Bonn students)
- Storage space for tools/modules is available



OLYMPUS Monte Carlo

Monte Carlo

- based on GEANT4
- integrated with ROOT for analysis

Reconstruction

- separate program to handle both Monte Carlo and real data
- using GEANT4 for swimming tracks through magnetic field and generating hits in detectors
 - start with geantino
 - progress to actual particles with energy loss
 - add kinematic constraints

Manpower

- several people starting to get involved
 - MIT students - reconstruction, background simulation, GEM tracker optimisation
 - DESY physicists - reconstruction
 - Hampton University - luminosity monitor simulation
 - Mainz - symmetric Möller detector
- still lots to do

Test experiment

- With OLYMPUS target installation in January 2011 and lepton sign reversal implemented, a test experiment can be carried out in the months February through July 2011
- Measurement of target density distribution
- Study background situation for e^+ / e^-
- Begin to study systematics
- Test sub-detector reconstruction

Setup for 2 GeV beam

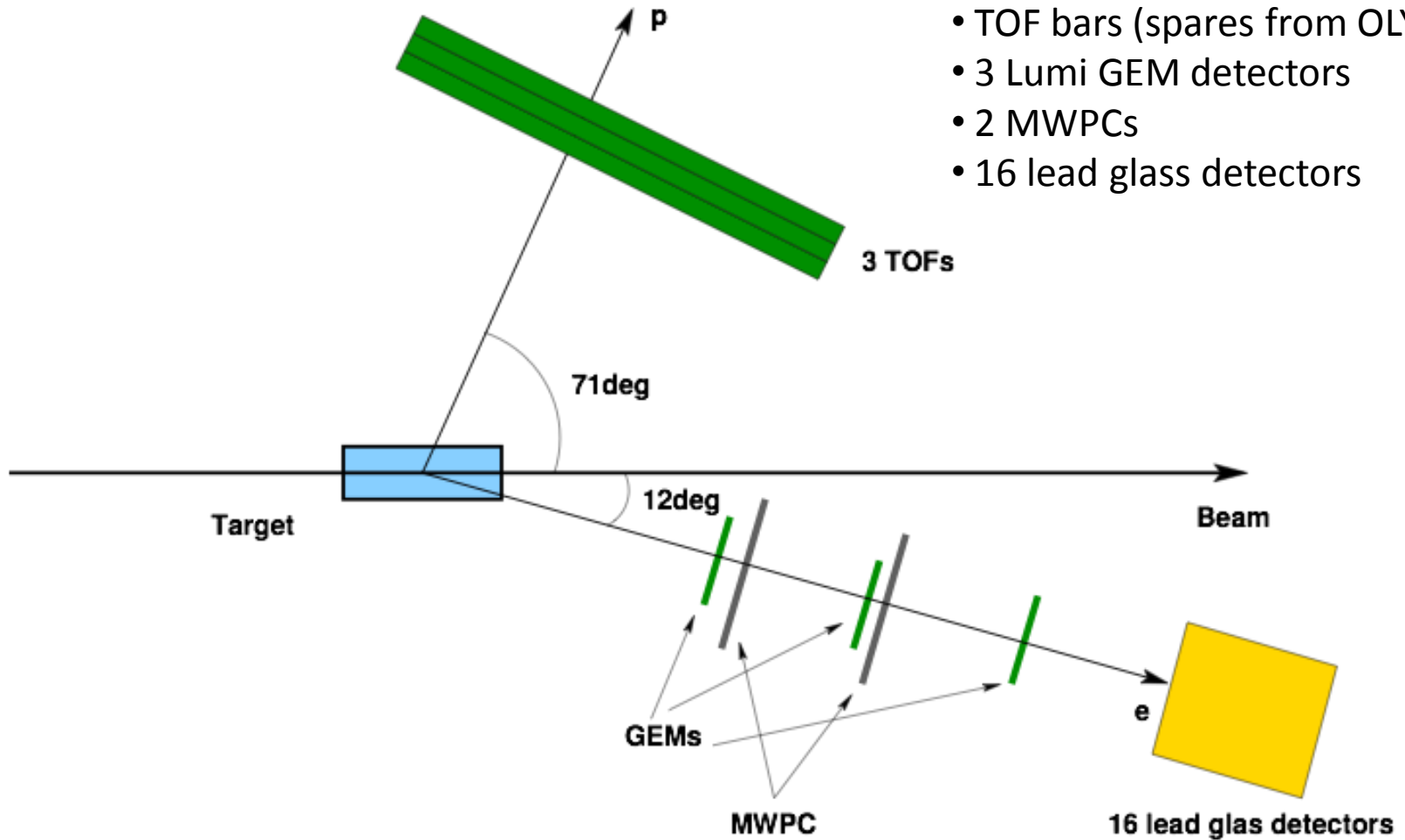

Simulation: z reconstruction

Vertex Resolution

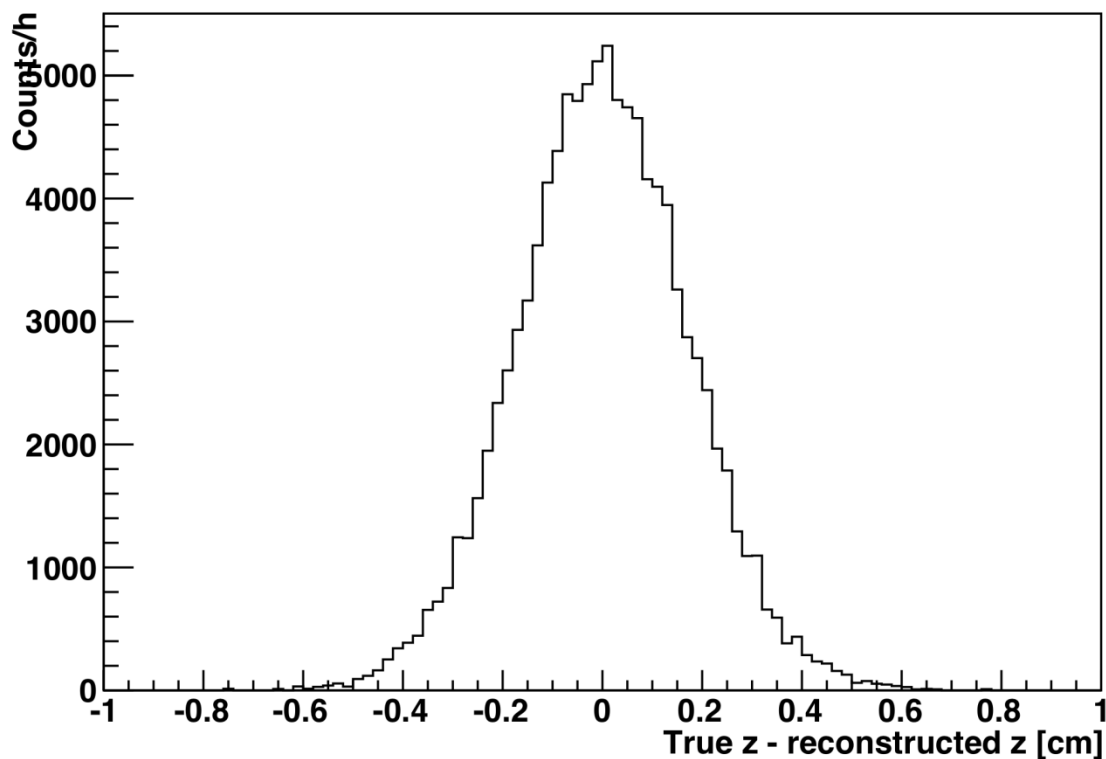

Count rates:

TOF: 64/s

GEMs: 40/s

Coincidences: 19/s

1 hour to get adequate statistics
(at 2 GeV)

Measurement of backgrounds in vicinity of OLYMPUS

- 2 organic scintillators 3 cm underneath beamline located +/- 3 m around OLYMPUS target point
- Active area approx. 8 cm x 8 cm
- Signals are discriminated and fed to scalers (1 Hz readout rate)



Count rate vs. beam current

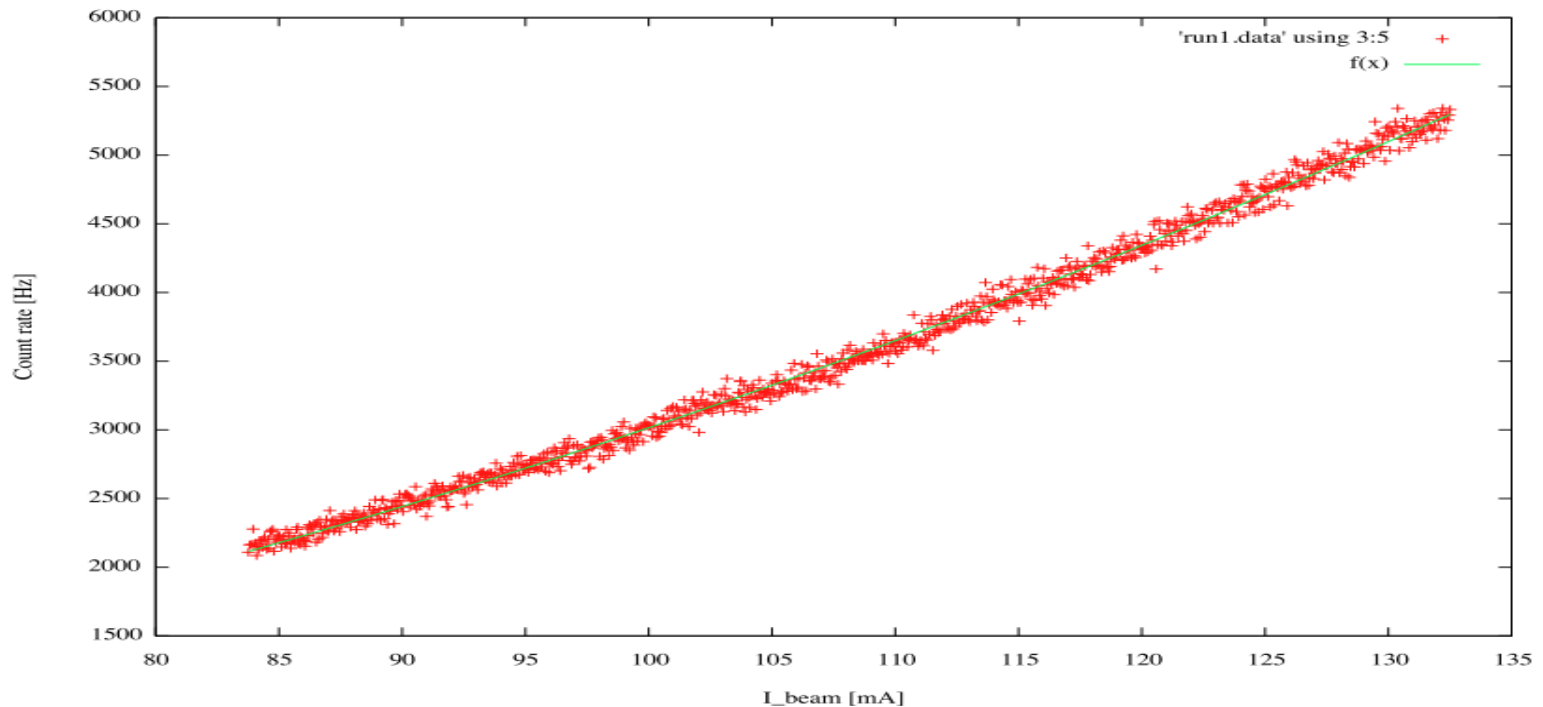

- Clear correlation
- Fit $f(I) = a \cdot I + b \cdot I^2$
 - $a = 0 \pm 0.1$ (synch. rad.)
 - $b = 0.3 \pm 0.001$ (rest gas)
 - Verification with shielded scintillator planned

Injection in DORIS

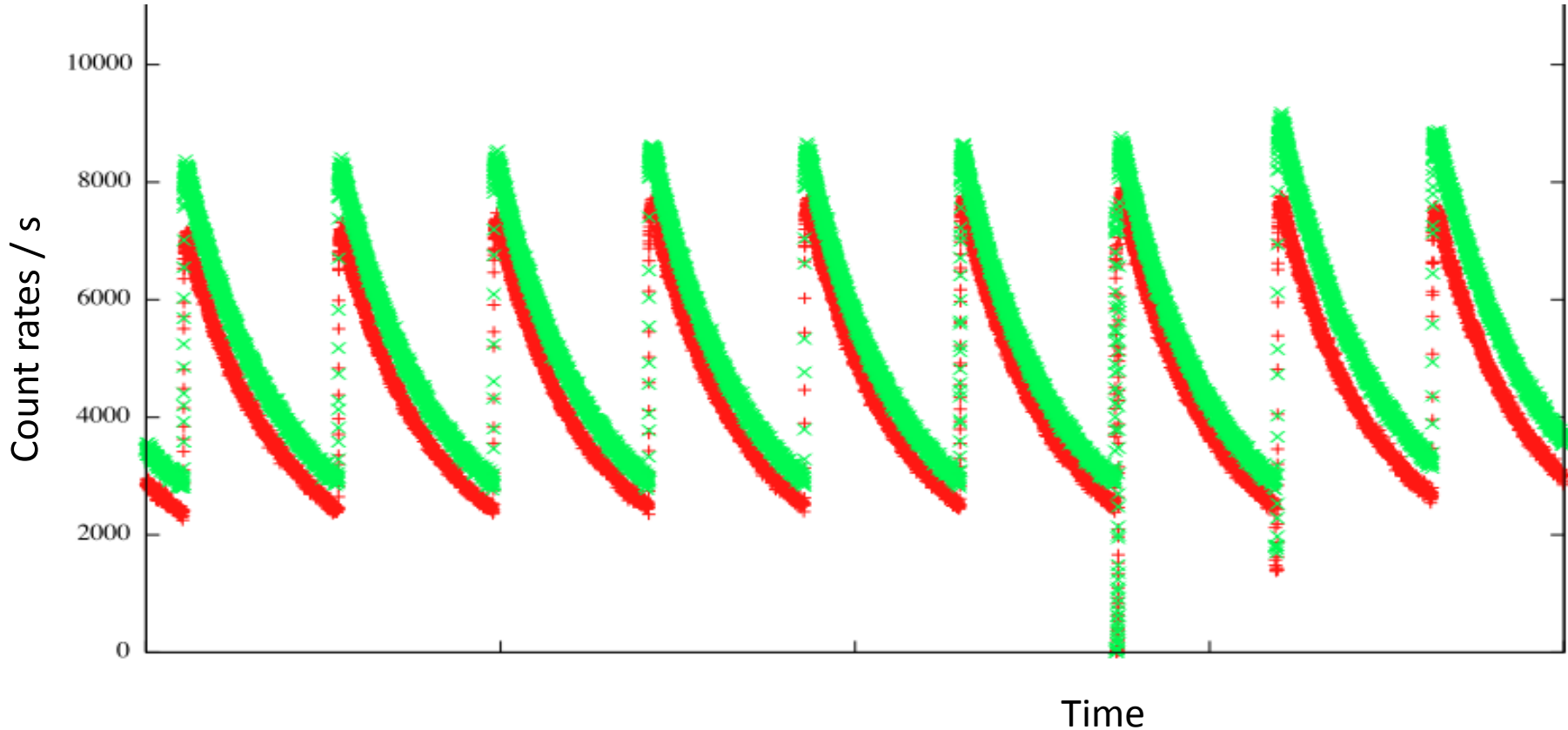

- **No** higher count rates during injections
- No need to decrease HV during injection

Schedule

OLYMPUS detector

- detector and spectrometer transferred to DESY as scheduled
- drift chambers completely rewired
- TOFs refurbished and calibration system implemented
- toroid assembled, to be powered in November
- DAQ system operational
- lumi monitor system in final production phase

Testing of OLYMPUS target at MIT-Bates

- target chamber, target cell, cryohead assembled
- gas feed system operational
- complete system being tested at Bates
- ship via air to DESY in November 2010
- assemble and test in three pieces in December 2010
- install in December-February shutdown

Install test experiment in December 2010-February 2011

Install complete experiment in August 2011

Commission in fall 2011

Take data in two running blocks in 2012

Detailed schedule with critical milestones available

Summary

- Steady progress on realization of experiment since last PRC
- Toroid and detectors successfully transported across Atlantic and being prepared for operation.
- Target being tested at MIT-Bates at present in preparation for shipping to DESY by early December 2010.
- Test experiment will be installed in winter 2010/11 shutdown
- Schedule is tight but milestone of winter installation can be met