

Xtremix

Jehan Defonseka and Karen Chu



“It breaks the old
paradigm of music before
dance.” Adam Lerer

The Big Picture

- Controlling music with motion
- You can dance if you want to



The Block Diagram

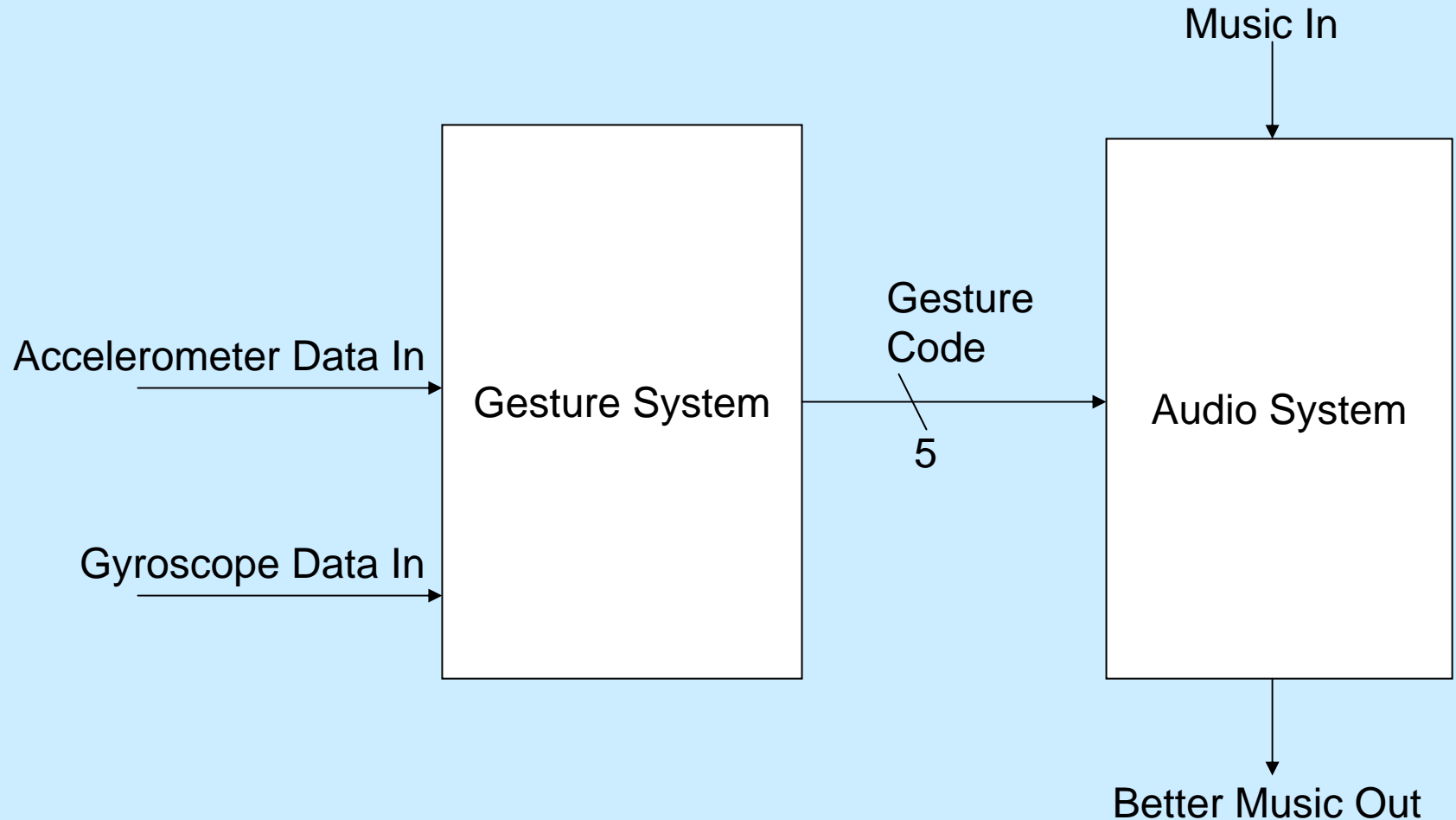

The Gesture System

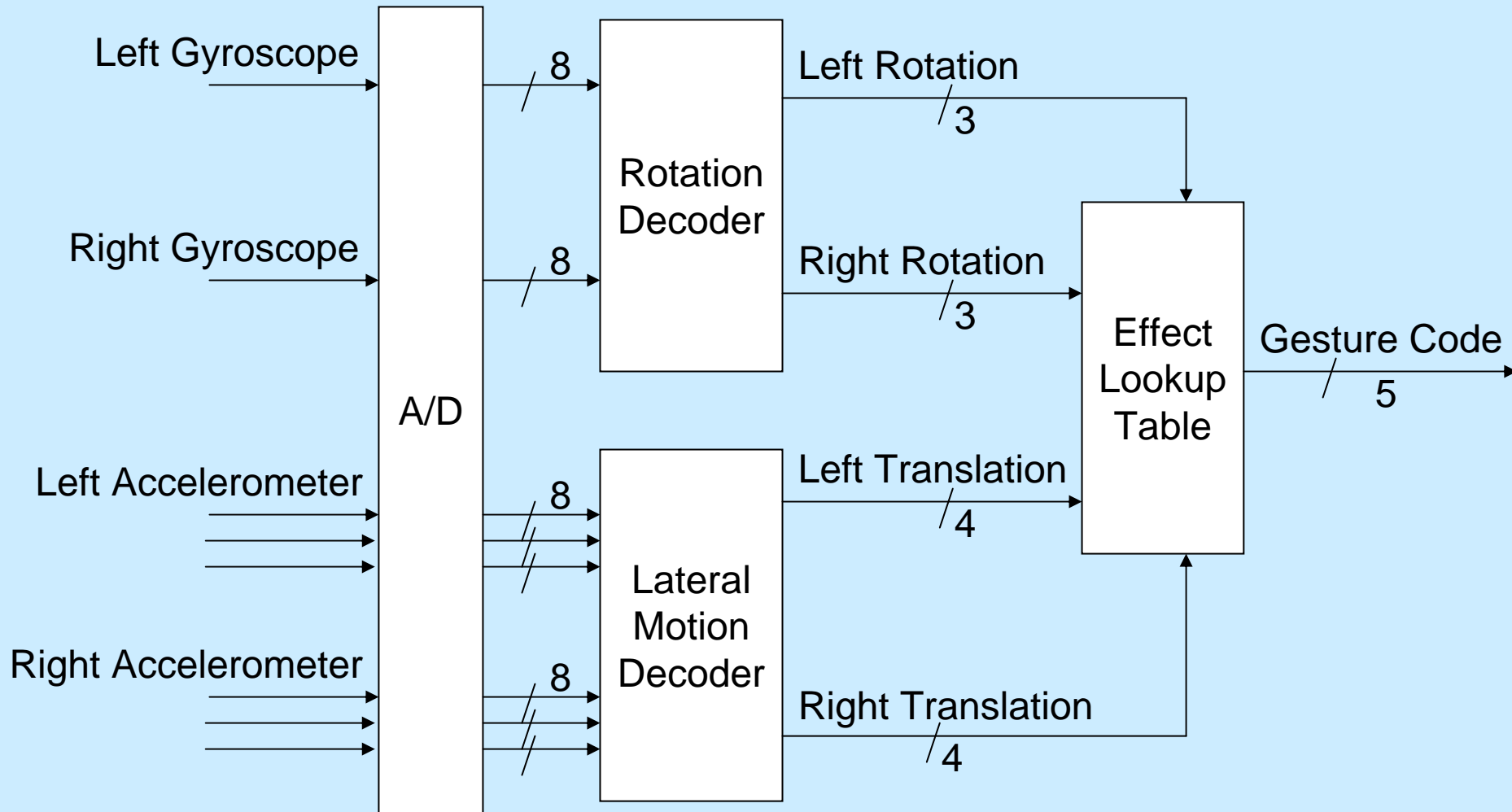

The Gesture Bank

- Volume control

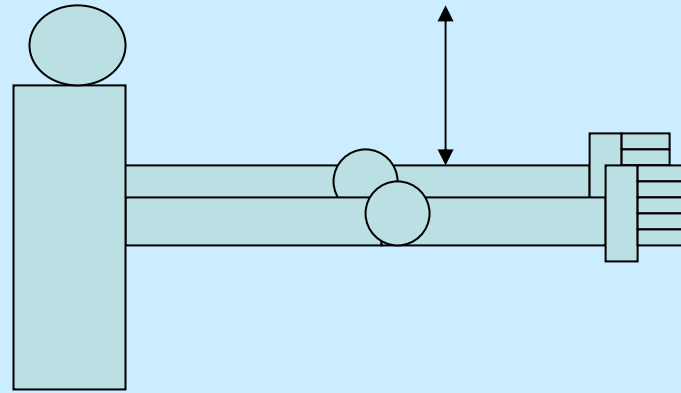

- Frequency filter

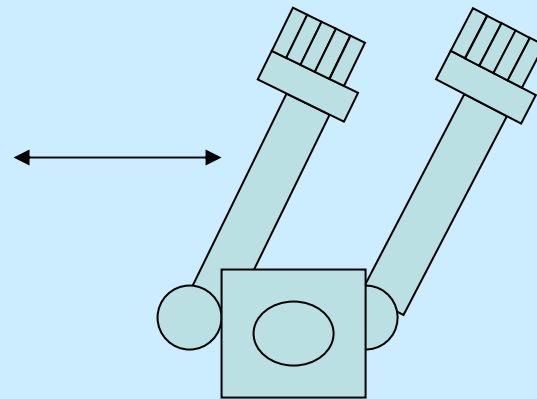

- Clip insertion

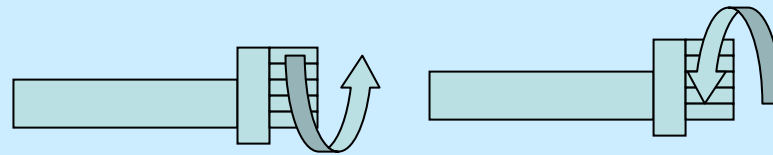

The Audio System

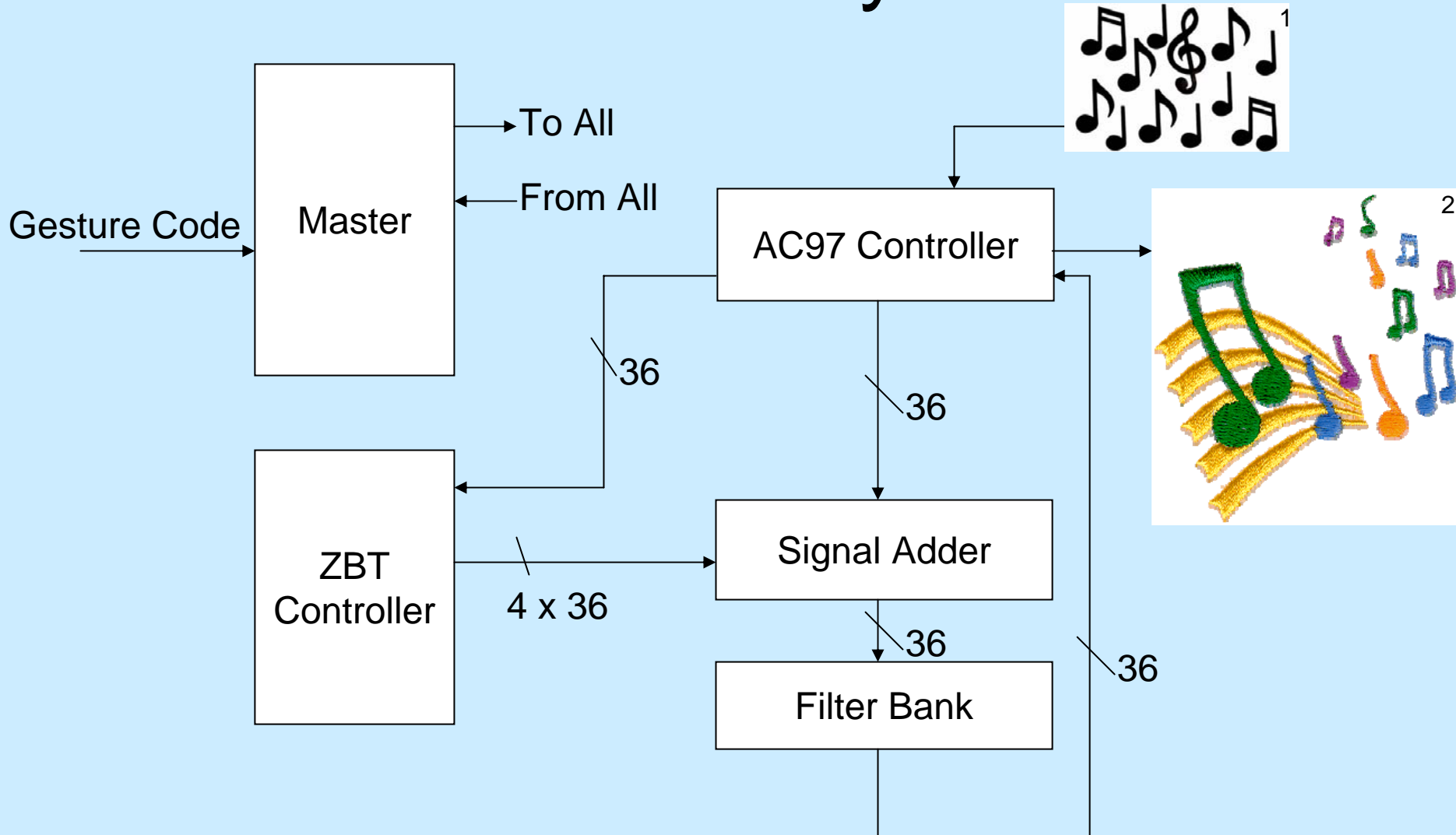

1. http://www.marsneedsguitars.com/blog_pics/music%20notes.jpg
2. <http://www.students.niu.edu/~z140184/website/music%20notes.gif>

The Filter Bank

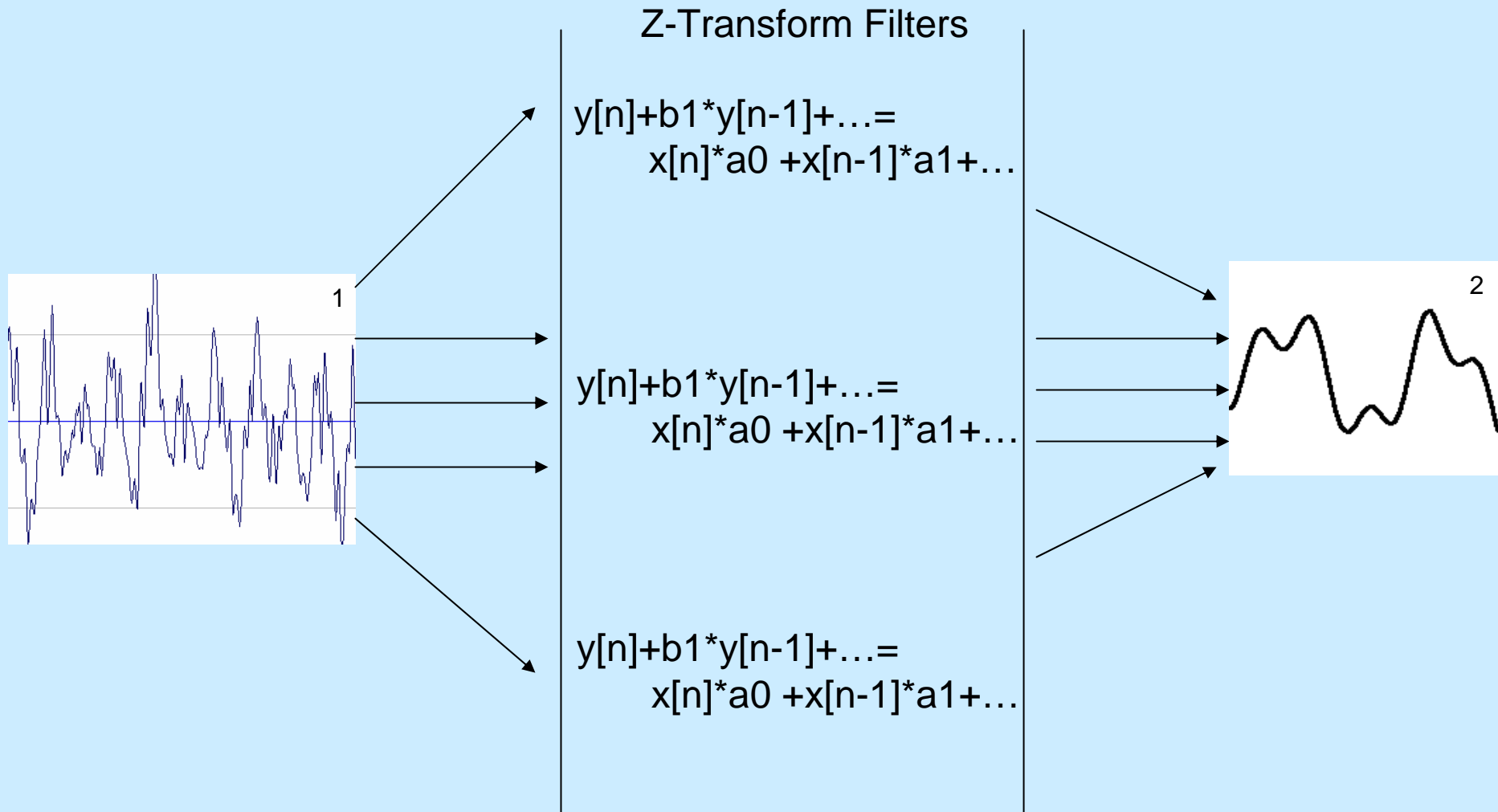

1. http://ac3filter.net/doc/ac3filter/pic/a_signal.png
2. http://www.doctrionics.co.uk/images/sig_23.gif

Conclusion

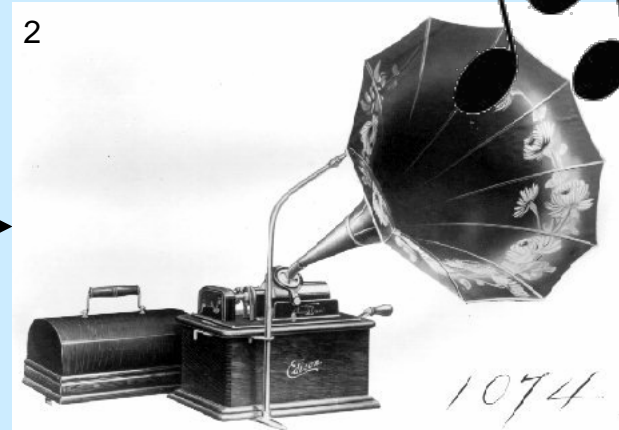

1. http://moonlightinterior.com/images/yoel4-edit_2-250.jpg
2. <http://www.sandiegohistory.org/curatorial/music/images/edison.jpg>