



A Voice Modulator

Adam Rosenfield
Lunduo Ye

6.111 Spring 2007

Features

- Inputs
 - Voice audio from microphone
 - Keyboard chords
- Modulate voice to match chord frequencies, preserving overtones
- Outputs
 - Voice at specified pitch(es)

Block Diagram

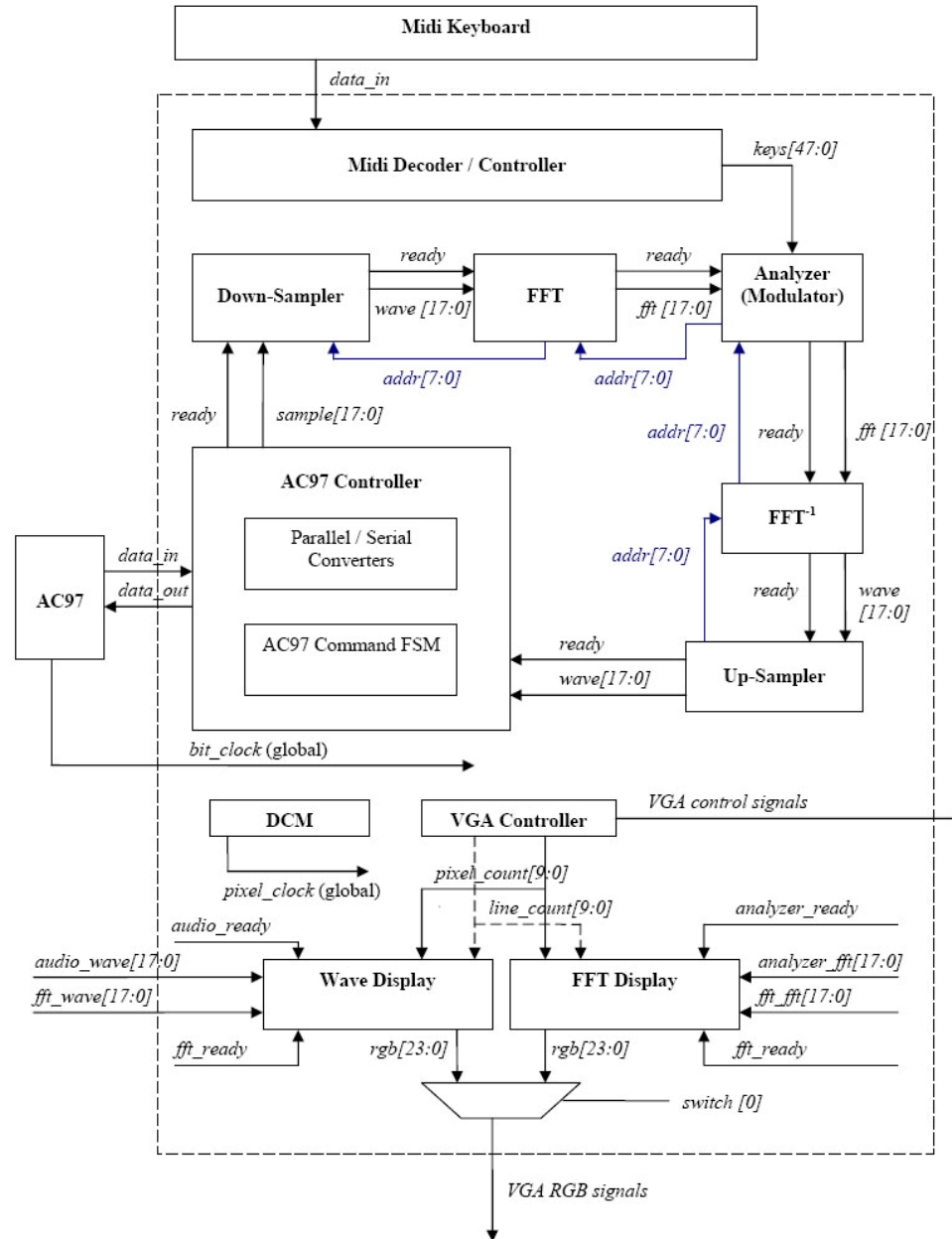

AC97 Interface

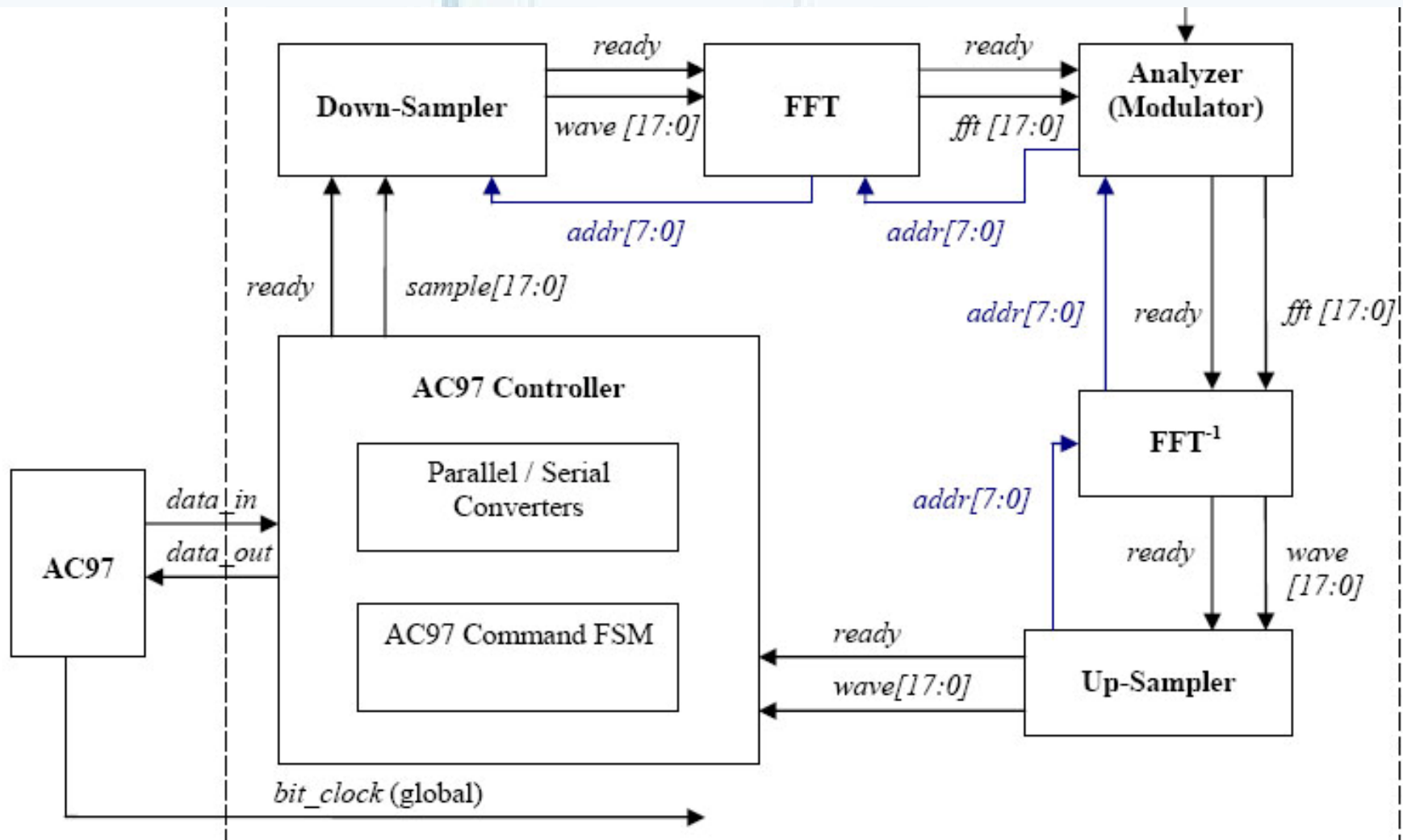

VGA Interface

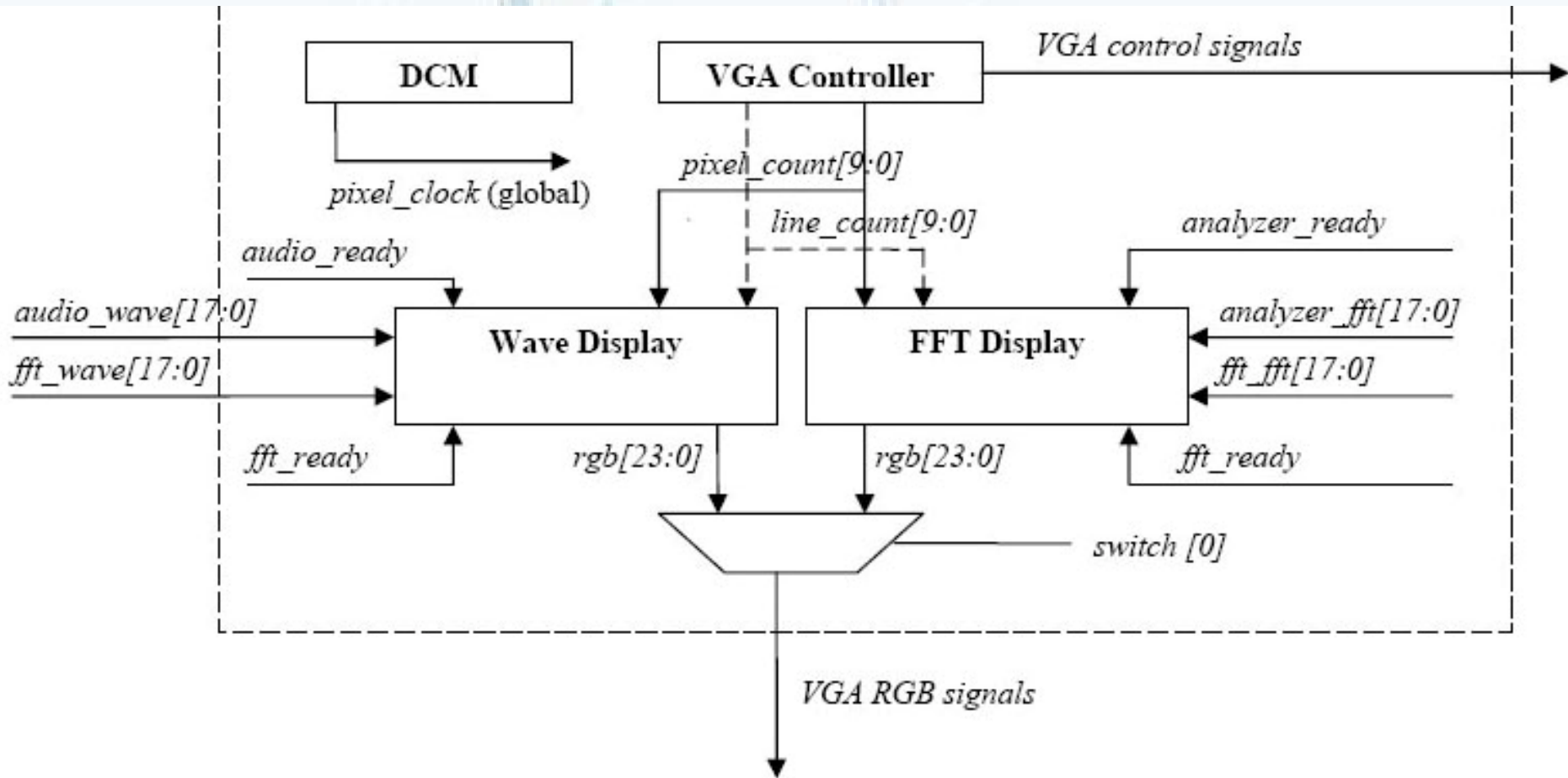

Implementation Details

- Analyze FFT on 256-frame period
- Block RAMs for audio caches
- Downsample as necessary to allow “realtime” playback