



Digital Whiteboard

Nathan Davis

Shaun Foley



The Digital Whiteboard

- Takes motion data from two axis accelerometers
- Position Information and Gesture Recognition to control interaction with whiteboard
- Functionality includes: freehand drawing or erasing, copy and paste, and interpretation of multiple movements as commands.

Overview

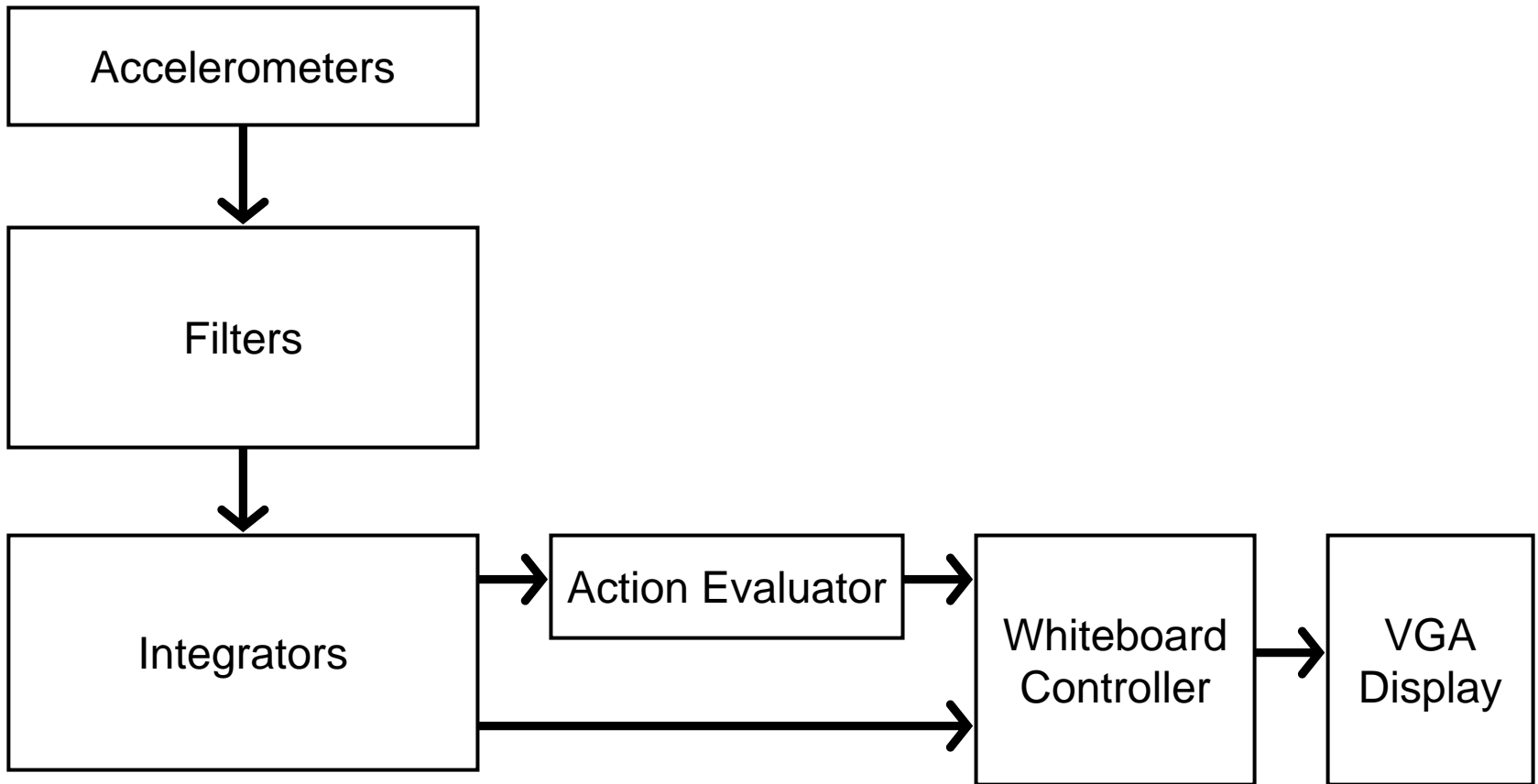

Motion

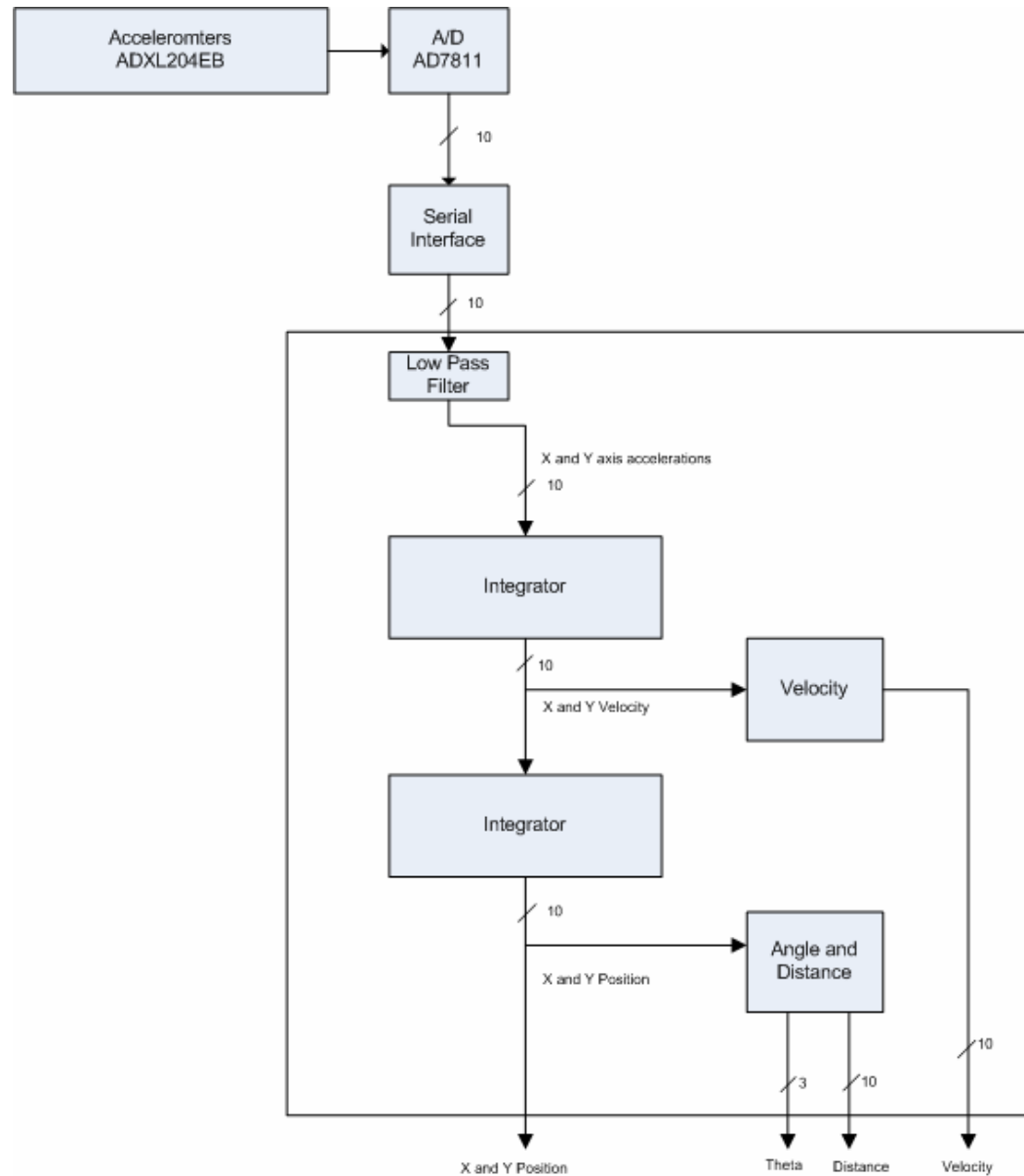

Detail

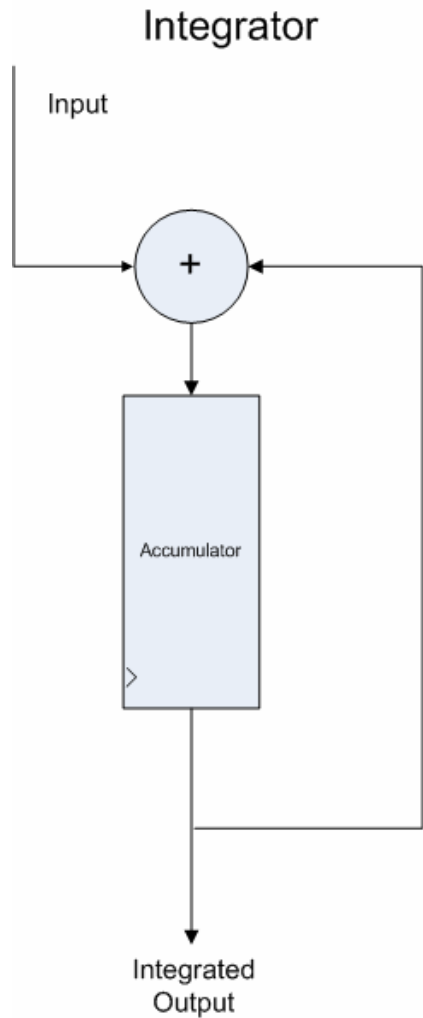

FIR Filter

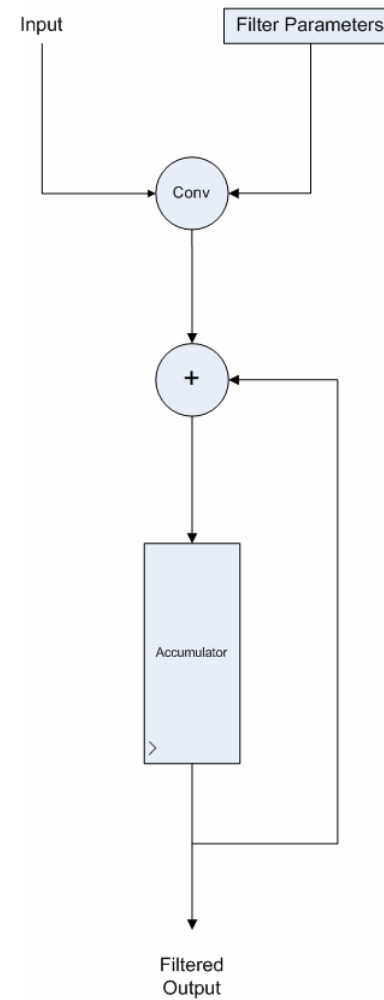

Action Evaluator

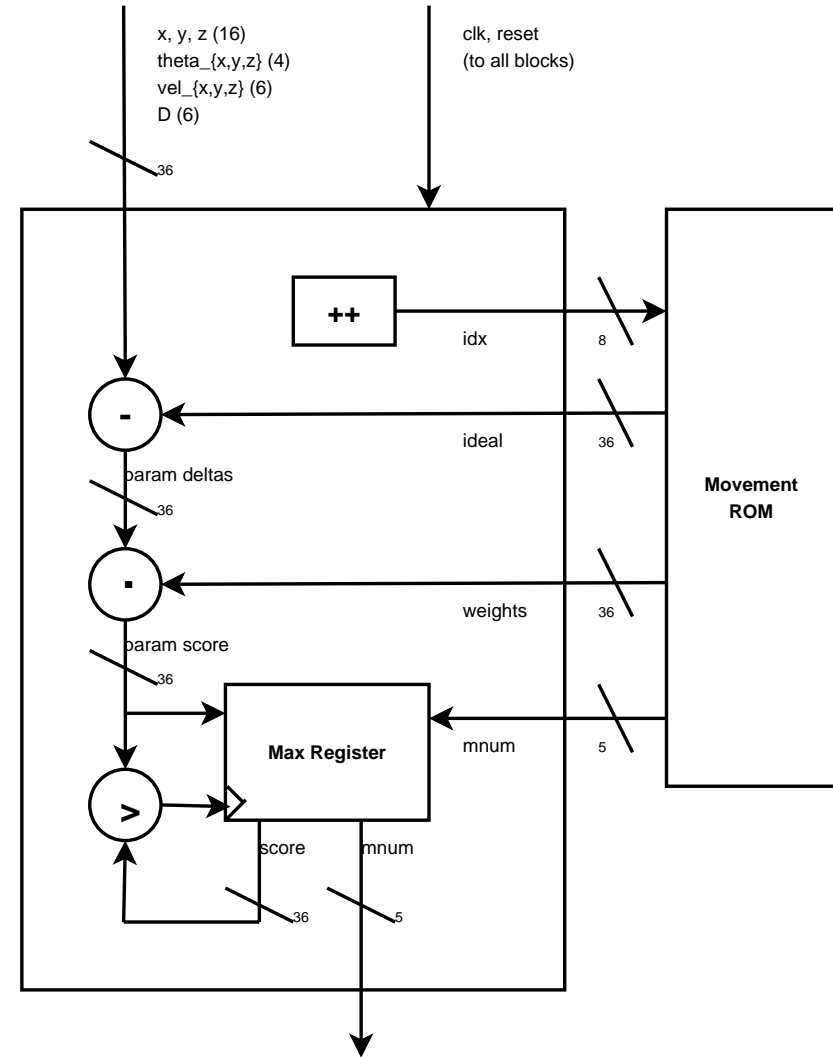
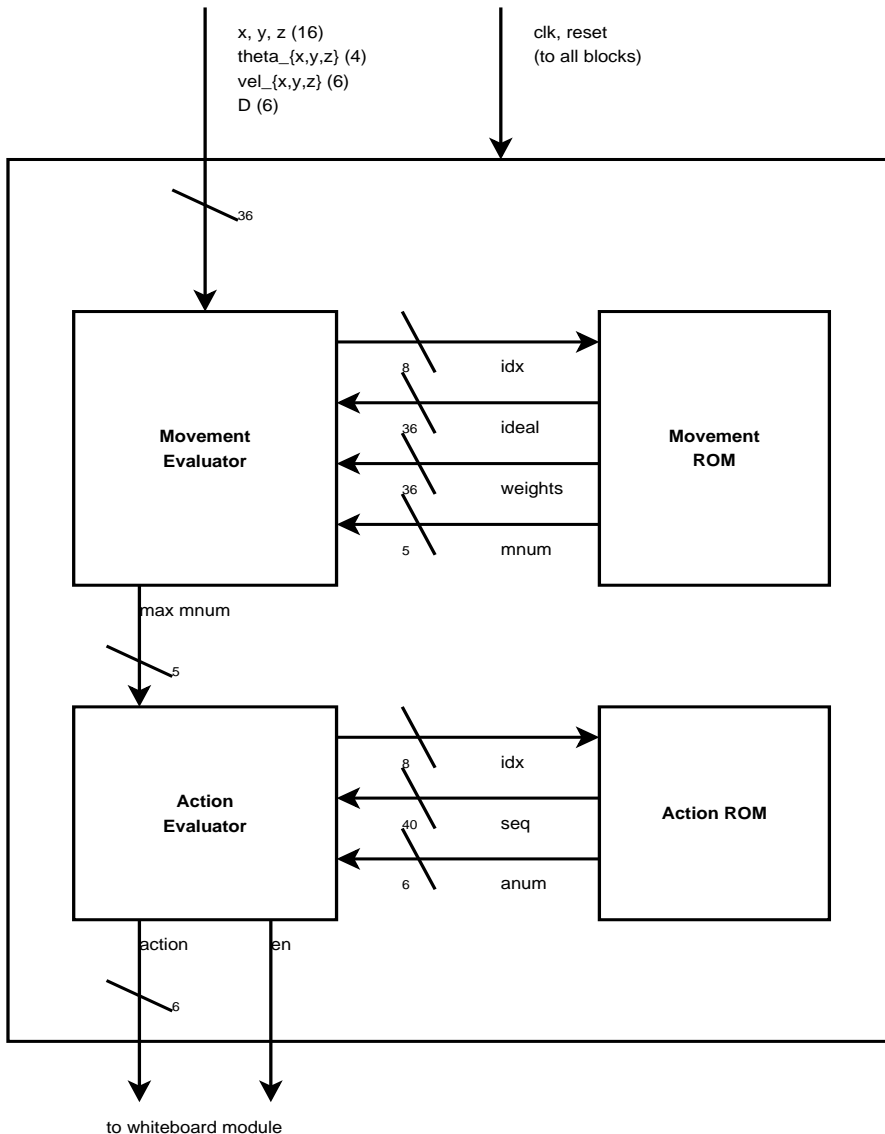

Whiteboard Controller

