

Lecture 13

6.111 Flat Panel Display Devices

Outline

- Overview Flat Panel Display Devices
 - How do Displays Work?
 - Emissive Displays
 - Light Valve Displays
- Display Drivers
 - Addressing Schemes
 - Display Timing Generator
 - Gray Scale / Color Schemes

For more info take graduate course, 6.987 on flat panel displays

Tayo Akinwande

Applications of Flat-Panel Displays

SMALL FORMAT



Medical Defibrillator



MP3 Player



Personal Digital Assistant



Car Navigation & Entertainment

LARGE FORMAT

Courtesy of PixTech



Desktop Monitor (color)



Large Screen Television (color)

Some Display Terminologies

Term	Definition
Pixel	Picture element—The smallest unit that can be addressed to give color and intensity
Pixel Matrix	Number of Rows by the Number of Columns of pixels that make up the display
Aspect Ratio	Ratio of display width to display height; for example 4:3, 16:9
Resolution (ppi)	Number of pixels per unit length (ppi=pixels per inch)
Frame Rate (Hz)	Number of Frames displayed per second
Viewing Angle (°)	Angular range over which images from the display could be viewed without distortion
Diagonal Size	Length of display diagonal
Contrast Ratio	Ratio of the highest luminance (brightest) to the lowest luminance (darkest)

Information Capacity of Displays

(Pixel Count)

Resolution	Pixel	Ratio
Video Graphic Array (VGA)	640 x 480 x RGB	4:3
Super Video Graphic Array (SVGA)	800 x 600 x RGB	4:3
eXtended Graphic Array (XGA)	1,024 x 768 x RGB	4:3
Super eXtended Graphic Array (SXGA)	1,280 x 1,024 RGB	5:4
Super eXtended Graphic Array plus (SXGA+)	1,400 x 1,080 x RGB	4:3
Ultra eXtended Graphic Array (UXGA)	1,600 x 1,200 x RGB	4:3
Quad eXtended Graphics Array (QXGA)	2048 x 1536 x RGB	4:3
Quad Super eXtended Graphics Array (QSXGA)	2560 x 2048 x RGB	4:3

Display Devices, No. 21, Spring 2000, p. 41

How Do Displays Work?

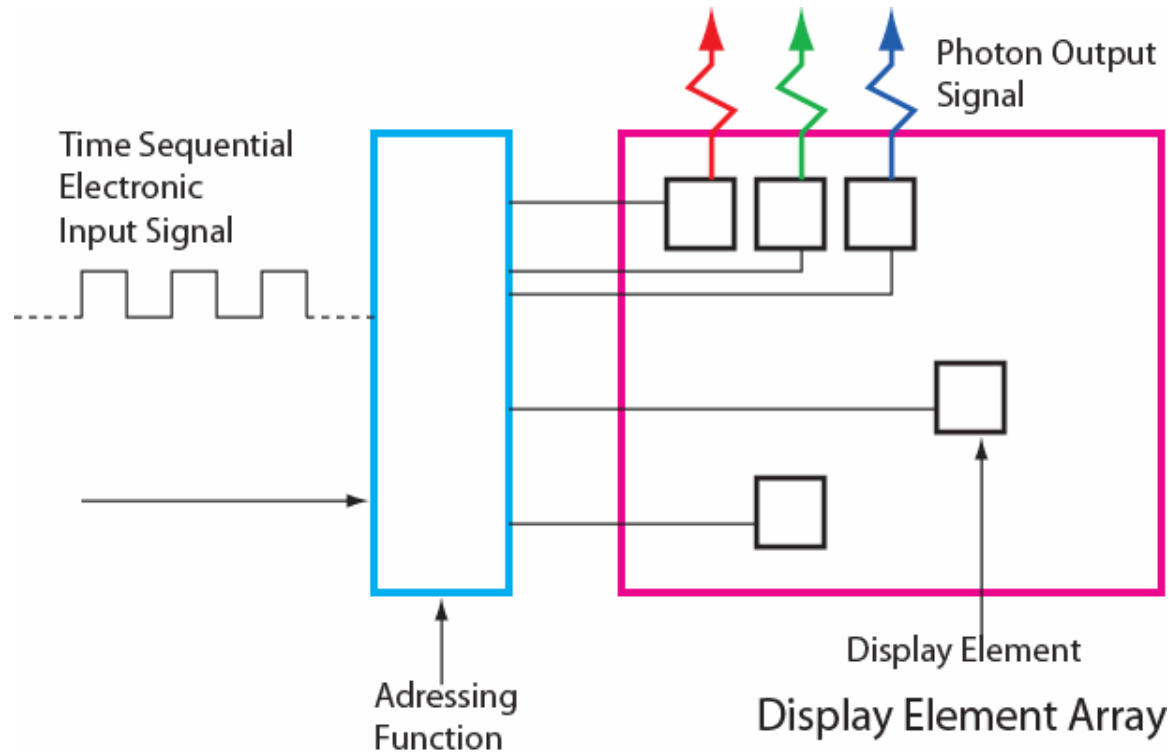

Pankove

- Electronic display converts “**Time Sequential Electrical Signals**” into spatially and temporally configured light signal (**images**).
 - Electrical signals are appropriately routed to the various display elements (**similar to memory addressing**)
 - Display element (pixel) converts the routed electrical signal at its input into light of certain wavelength and intensity (**inverse of image capture**)

Human Eye— Spectral Response

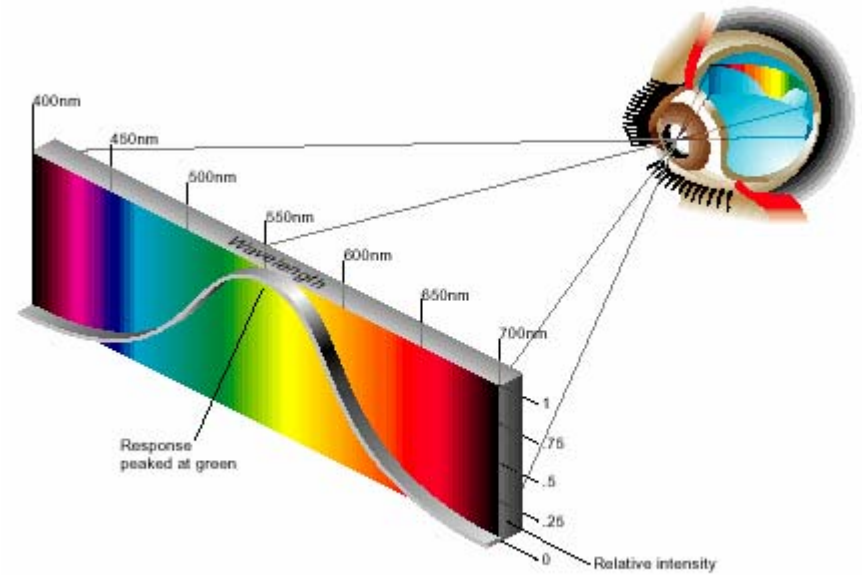
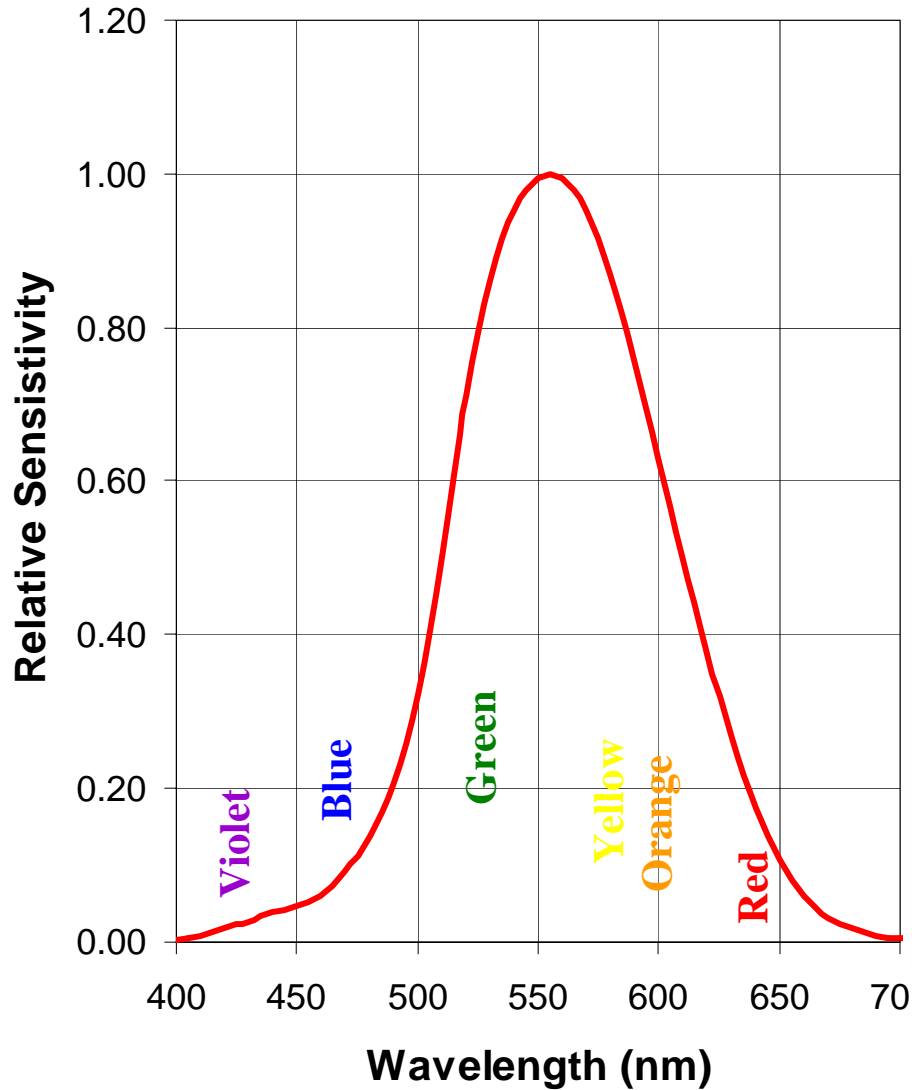

Figure 15. CIE Photopic Curve (Spectral Sensitivity of the Human Eye).

Emissive Displays

- Displays that **generate photons** when an electrical signal is applied between the terminals
- Energy causes excitation followed by excitation relaxation
 - Hole + Electron recombination
 - Exciton formation and annihilation
 - Relaxation of excited radicals in a plasma
- The different types of **Luminescence** differ mostly in the way the holes and electrons are generated
 - holes and electrons are generated by UV in a phosphor which then recombine and generate **red, green or blue** light — **Photoluminescence or Phosphorescence**
 - holes and electrons injected by pn junction or generated by impact ionization or excitation which then recombine and generate **red, green or blue** light — **Electroluminescence**
 - holes and electrons generated by electron beam which then recombine and generate **red, green or blue** light — **Cathodoluminescence**
- Examples of Emissive Flat Panel Displays
 - Electroluminescence (**L**ight **E**mitting **D**iode, **O**rganic-**L**ight **E**mitting **D**evelopments & Inorganic **E**lectroluminescent Displays)
 - Cathodoluminescence (**C**athode **R**ay **T**ube, **V**acuum **F**luorescent **D**isplay, **F**ield **E**mission **D**isplay)
 - Photoluminescence (**P**lasma **D**isplays)

Light Valve Displays

- Displays that “**spatially and temporally**” modulate ambient lighting or broad source of light and redirect to the eye.
- Display element spatially changes the intensity of plane wave of light using
 - Refraction
 - Reflection
 - Polarization change
- These displays are part of a broader class of devices called **Spatial Light Modulators** which in general operate through local
 - Amplitude change
 - Polarization change
 - Phase change
 - Intensity change
- Examples of Light Valve Displays
 - **Liquid Crystal Displays** (active & passive matrix)
 - **Deformable Mirror Displays**
 - **Membrane Mirror Displays**
 - **Electrophoretic Displays** (E-Ink)

Cathode Ray Tube

CRT Display

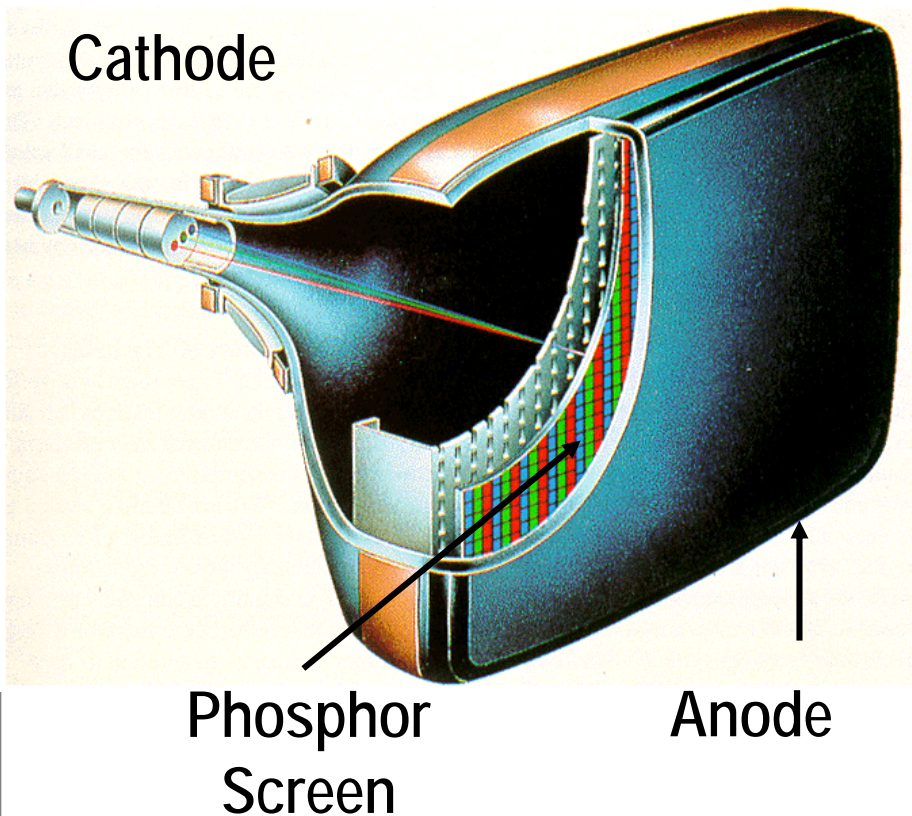

Electrons beam “boiled off a metal” by heat (**thermionic emission**) is sequentially scanned across a phosphor screen by magnetic deflection. The electrons are accelerated to the screen acquiring energy and generate light on reaching the screen (**cathodoluminescence**)

Courtesy of PixTech

Plasma Displays

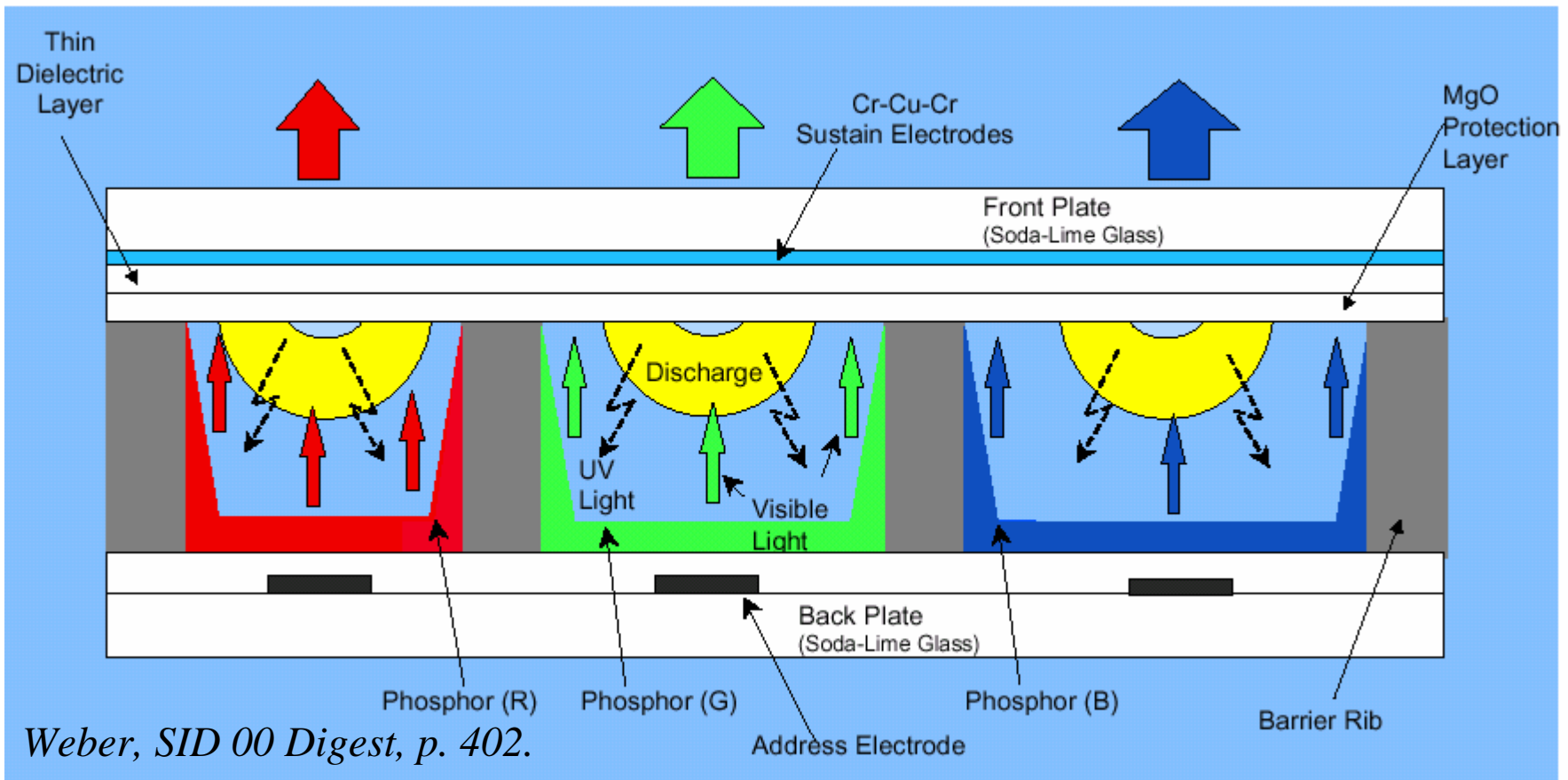

- Electrons are accelerated by voltage and collide with gasses resulting in ionization and energy transfer
- Excited ions or radicals relax to give UV photons
- UV photons cause hole-electron generation in phosphor and visible light emission

Organic Light Emitting Diode

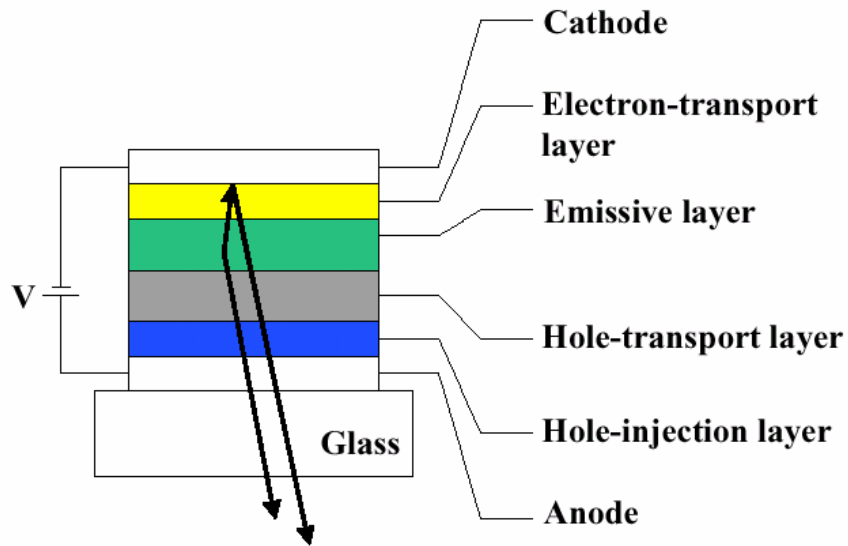

Figure 1. A typical OLED multilayer device structure

Rajeswaran et al., SID 00 Digest, p. 974



17-inch Active Matrix OLED

H.-K. Chung et al., SID 05 Digest, p. 956

Digital Mirror Device

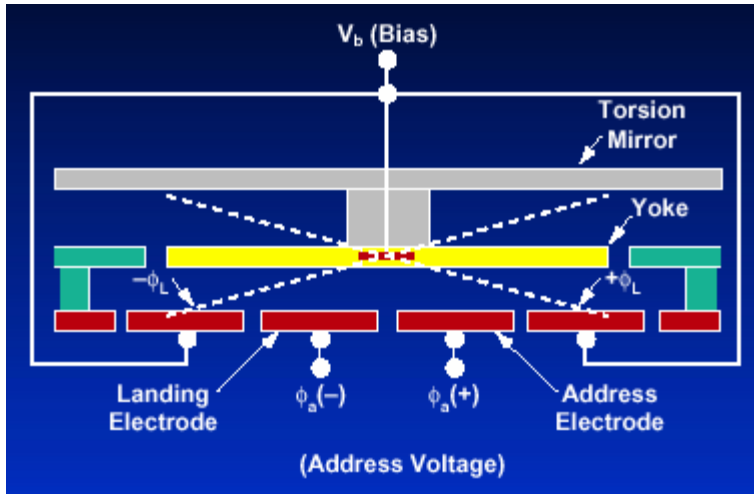

Courtesy of Texas Instruments

Applied voltage deflects
Mirror and hence direct light

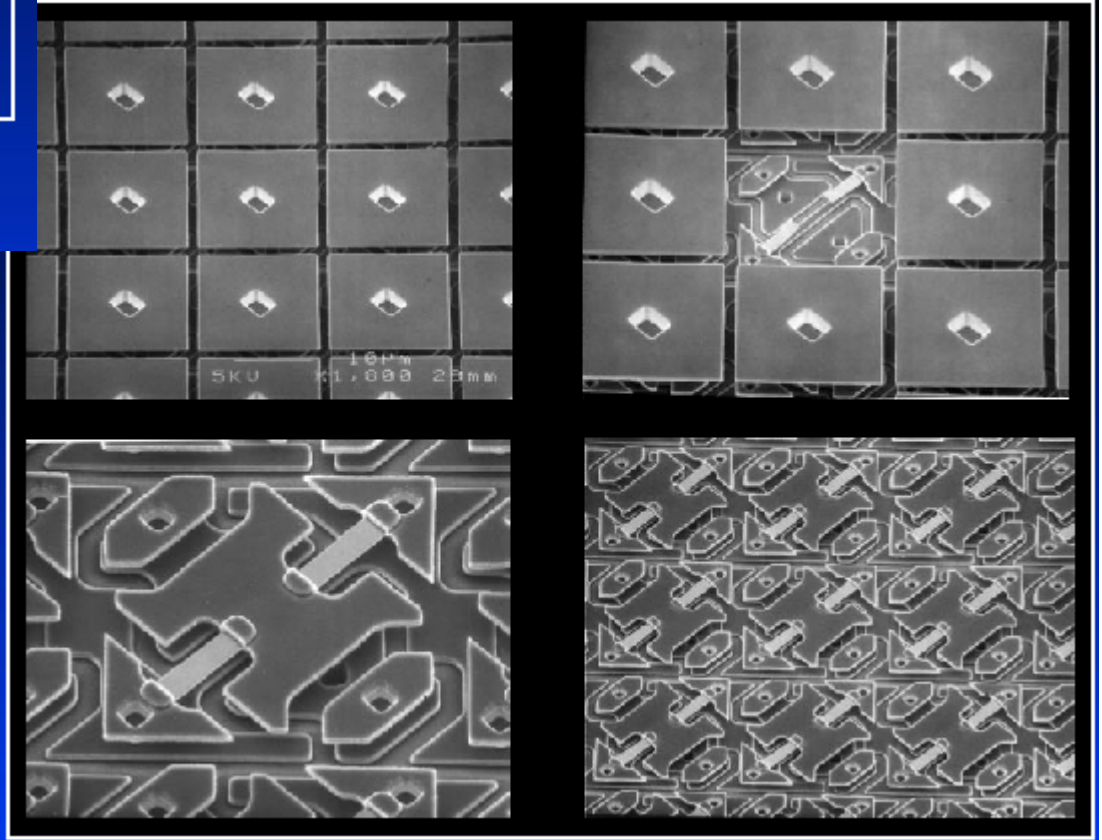

Liquid Crystal Displays

Liquid Crystals rotate the plane of polarization of light when a voltage is applied across the cell

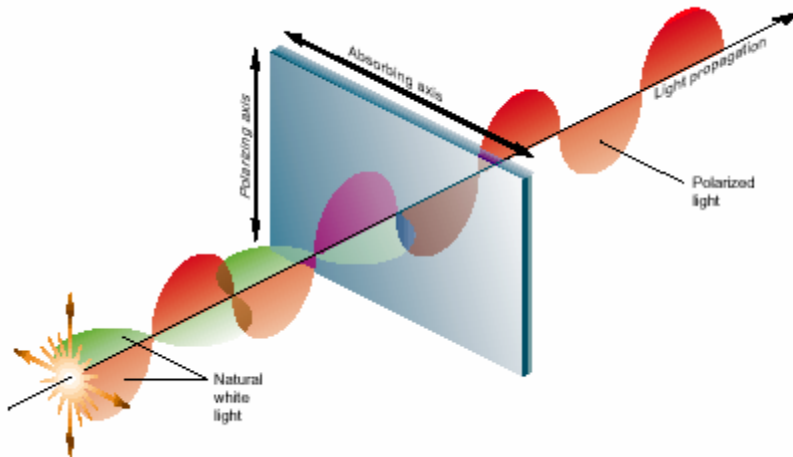
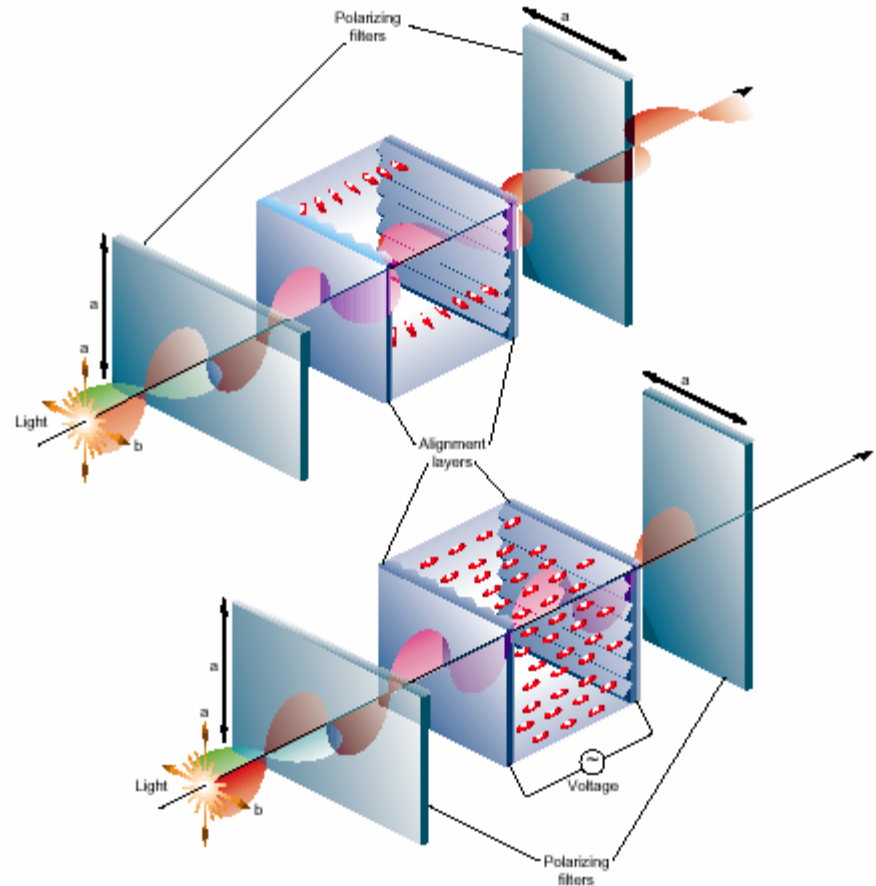
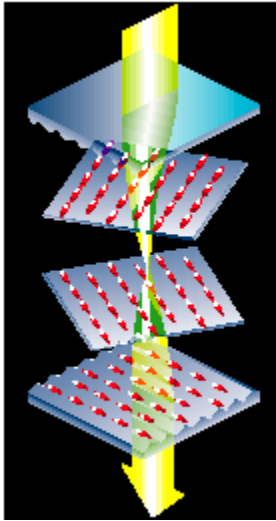

Courtesy of Silicon Graphics

TFT AMLCD

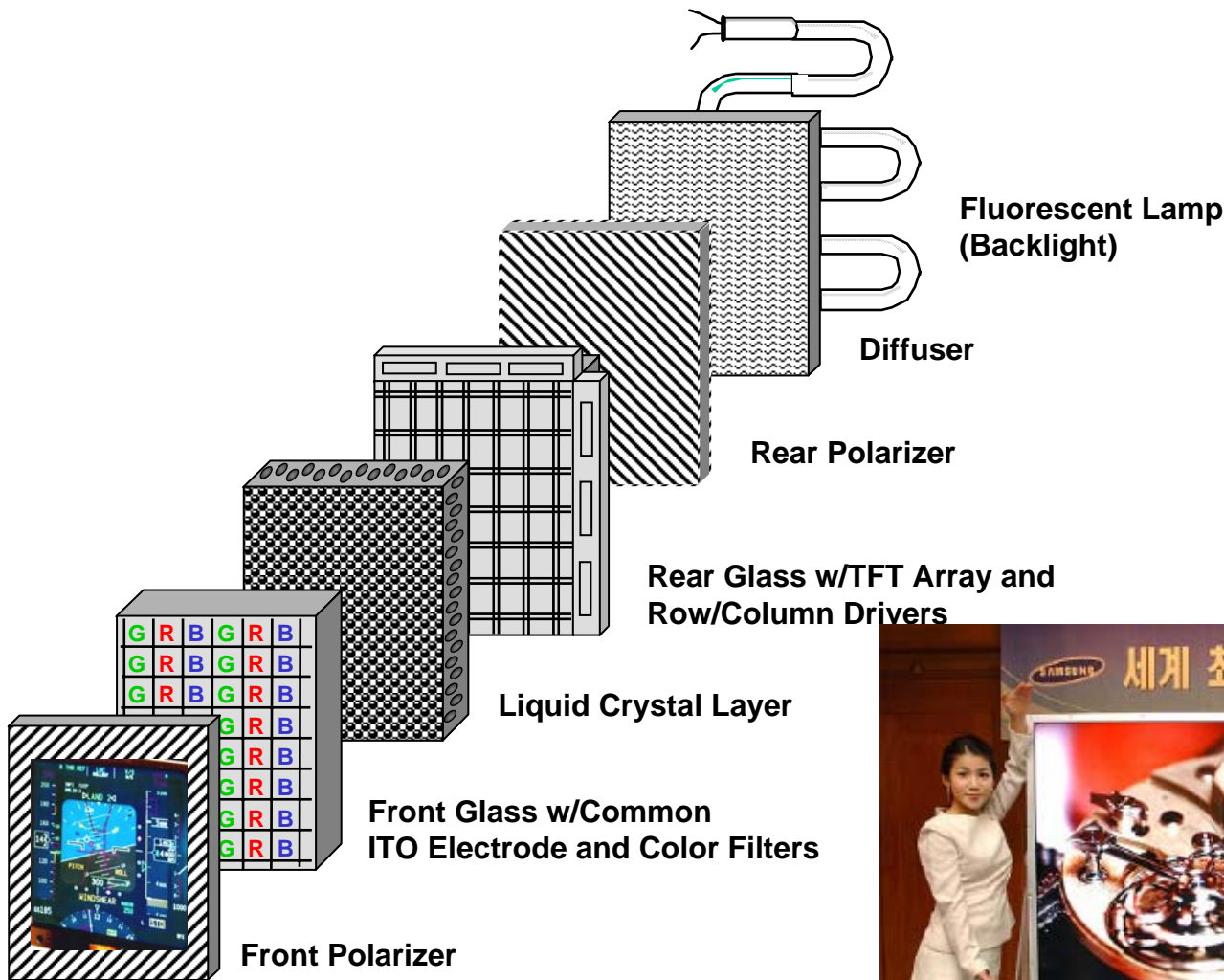

82" TFT AMLCD



K. Sarma

SID 05

Standard Display Addressing Modes

- Sequential Addressing (pixel at a time)
 - CRT, Laser Projection Display
- Matrix Addressing (line at a time)
 - Row scanning, PM LCD, AMLCD, FED, PDPs, OLEDs
- Direct Addressing
 - 7-segment LCD
- Random Addressing
 - Stroke-mode CRT

Sequential Addressing (Raster Scan)

- Time is multiplexed
 - Signal exists in a time cell
- A pixel is displayed at a time
 - Single data line
- Rigid time sequence and relative spatial location of signal
 - Raster scan
- Data rate scales with number of pixels
- Duty cycle scales with number of pixels
- Horizontal sync coordinates lines
- Vertical sync coordinates frames
- Blanking signals (vertical & horizontal) so that retraces are invisible

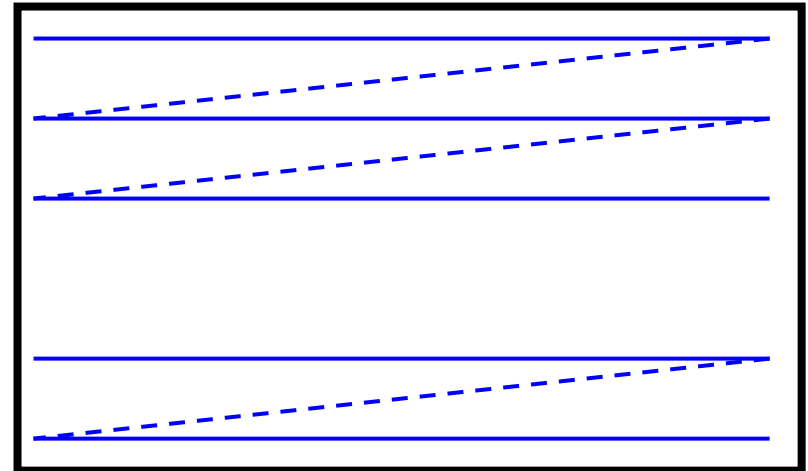
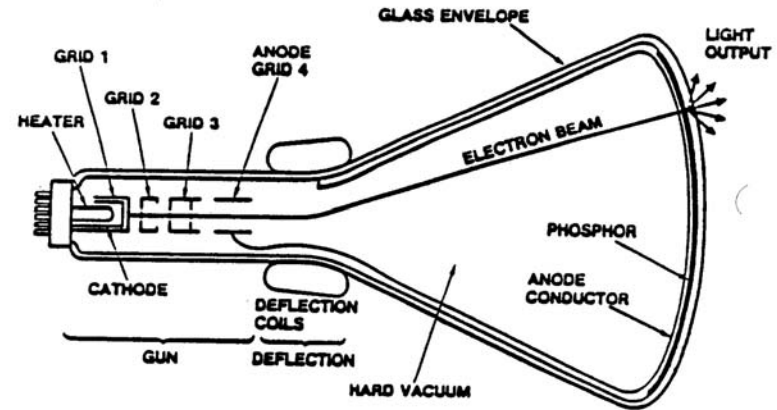

————— Scan Lines
- - - - - Retrace Lines

Composite Frames

- The 'frame' is a single picture (snapshot).
 - It is made up of many lines.
 - Each frame has a synchronizing pulse (vertical sync).
 - Each line has a synchronizing pulse (horizontal sync).
 - Brightness is represented by a positive voltage.
 - Horizontal and Vertical intervals both have blanking so that retraces are not seen (invisible).

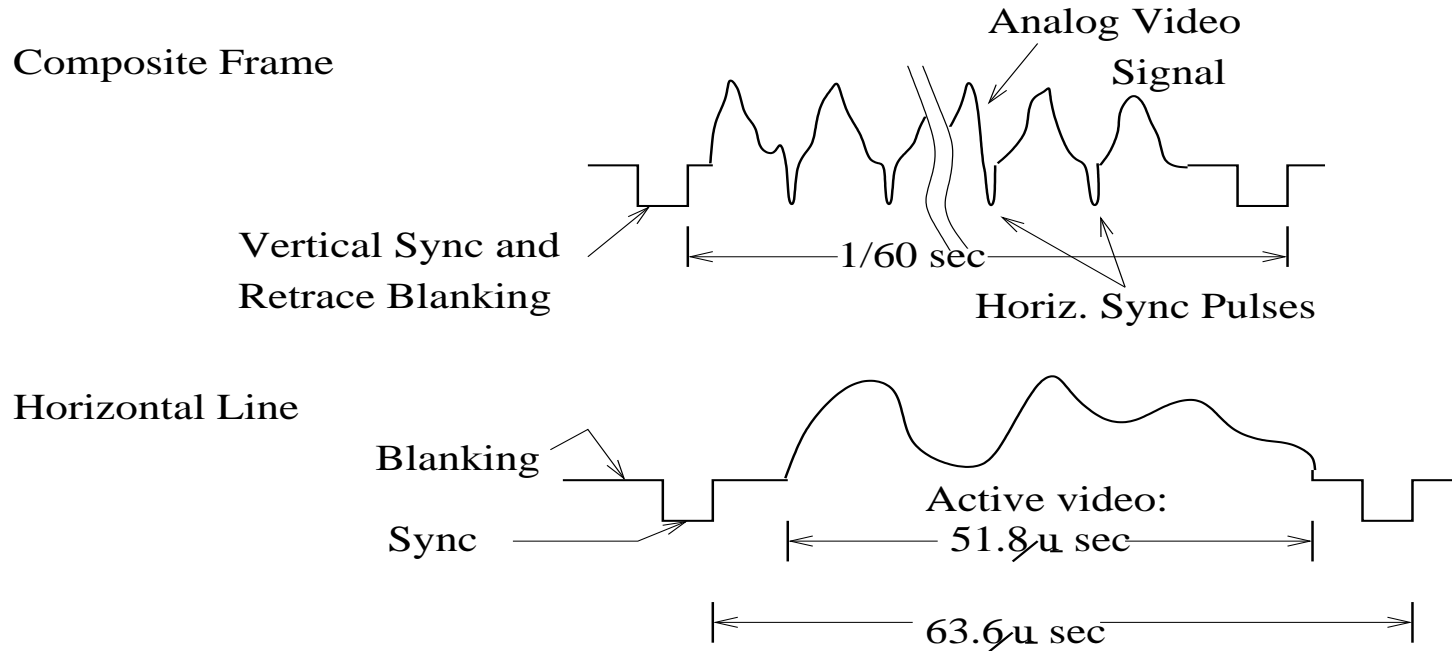

Slide by Professor Don Troxel

Display Timing Generator Parameters

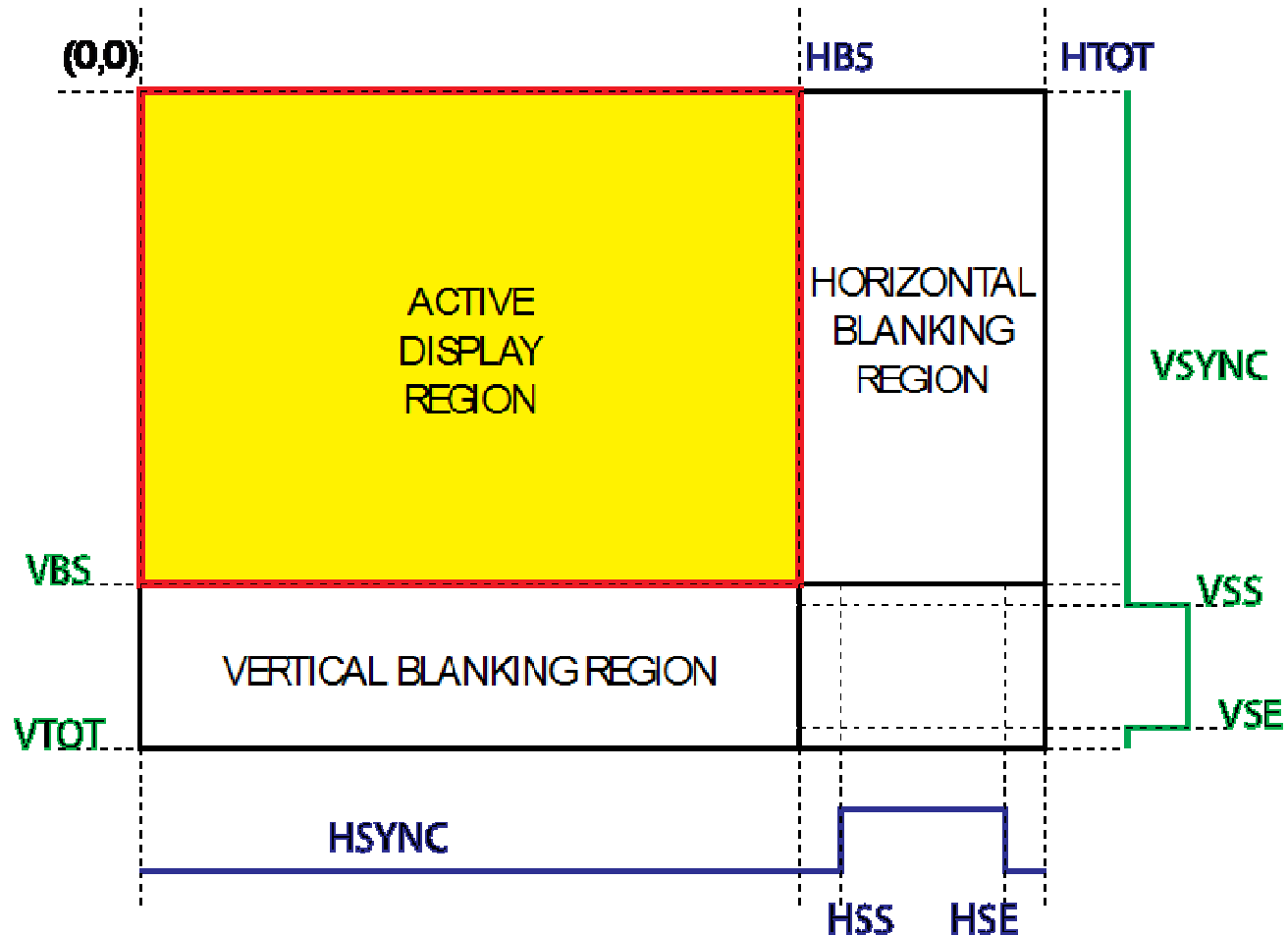

HTOT = Horizontal Total
HBS = Horizontal Blanking Start
HSS = Horizontal Sync Start
HSE = Horizontal Sync End

VTOT = Vertical Total
VBS = Vertical Blanking Start
VSS = Vertical Sync Start
VSE = Vertical Sync End

Direct vs. Matrix Addressing

Direct Driving

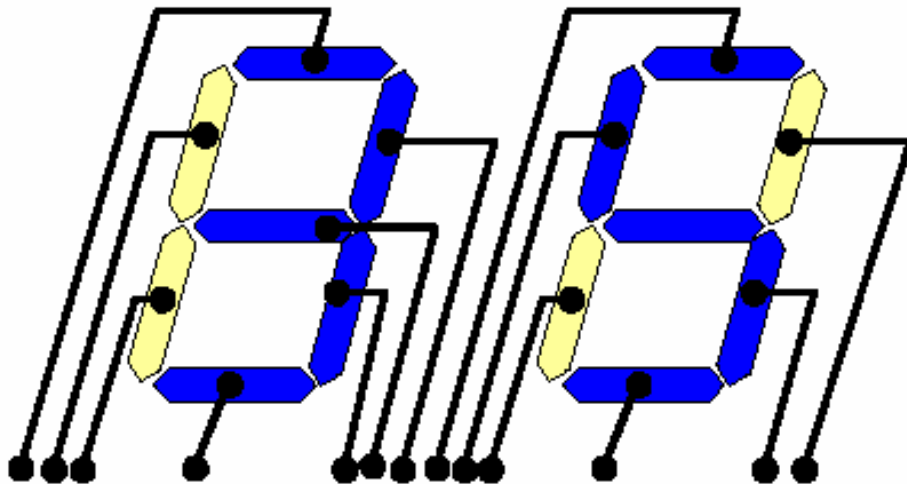

Segment Display
(7-segment)

Multiplex Driving

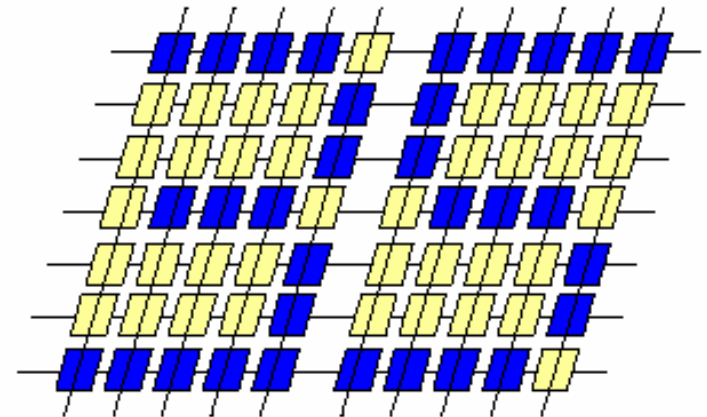

Matrix Display
(dot-matrix)

Matrix Addressing

- Time multiplexed
- Row at a time scanning
 - A column displayed during the time assigned to a row
- For a N rows by M columns display
 - M + N electrodes are required
- Row scanning rate scales with number of rows
- Data rate scales with number of pixels
- Duty cycle scales with number of rows

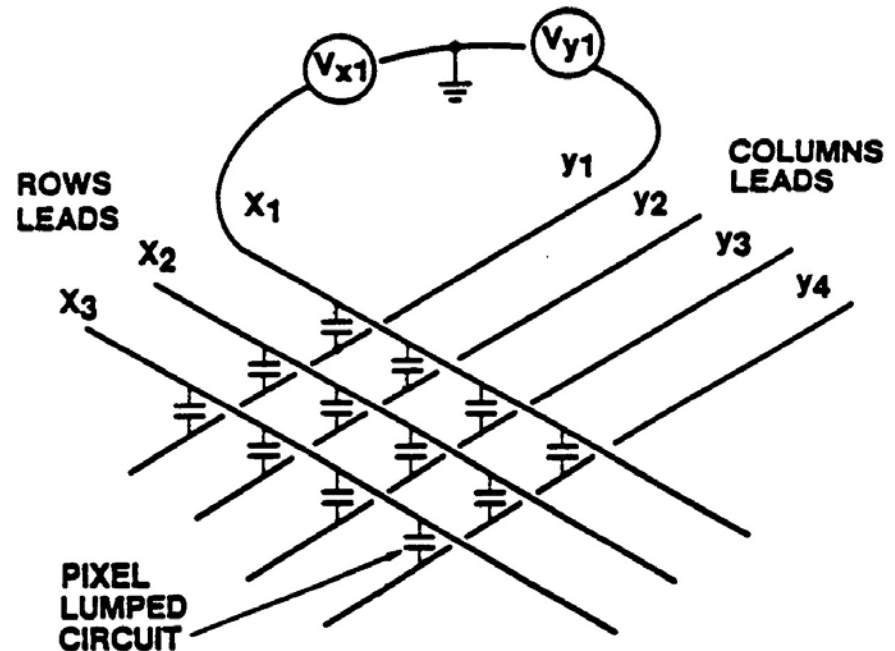

Active Matrix Addressing

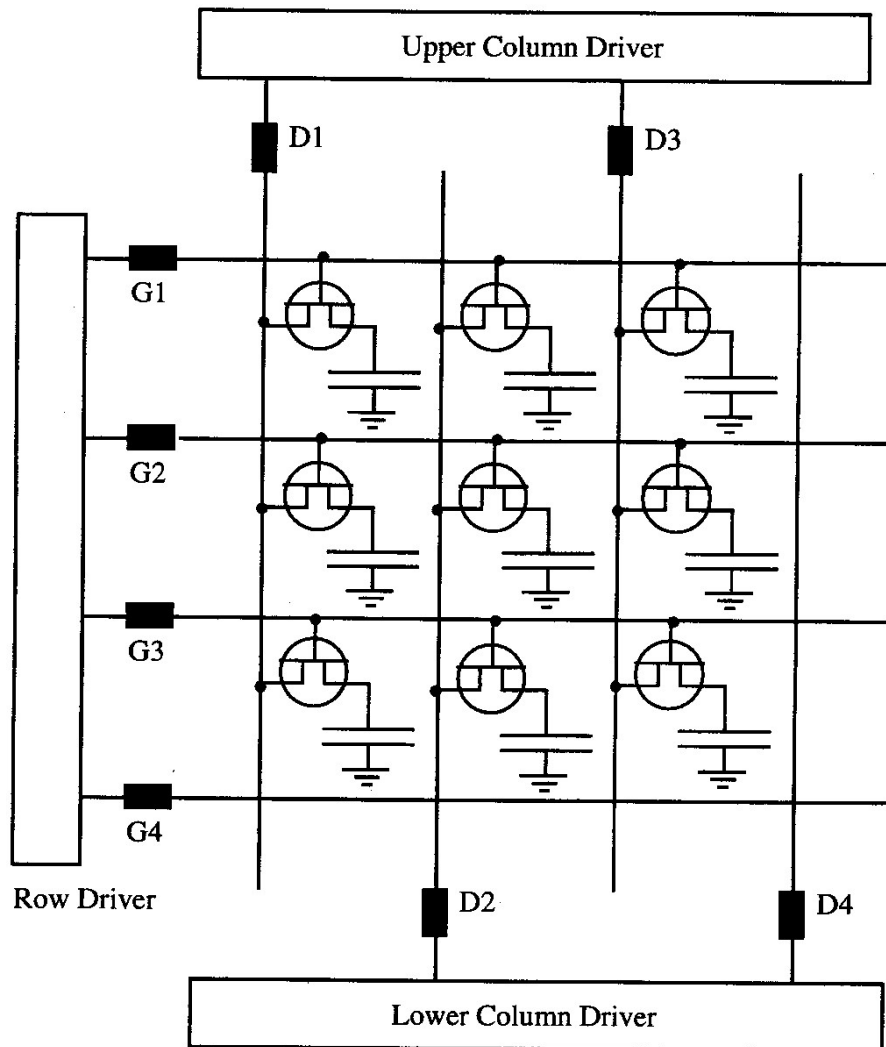

- Introduce non linear device that improves the selection.
- Storage of data values on capacitor so that pixel duty cycle is 100%
- Improve brightness of display by a factor of N (# of rows) over passive matrix drive
- Display element could be LC, EL, OLED, FED etc

Yeh & Gu

Grey Shades Generation Techniques

Spatial Modulation

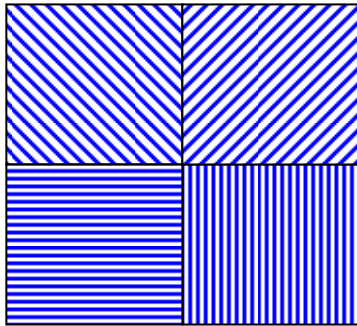

Individually
selectable
Areas per pixel area
per dwell time

Frame Modulation

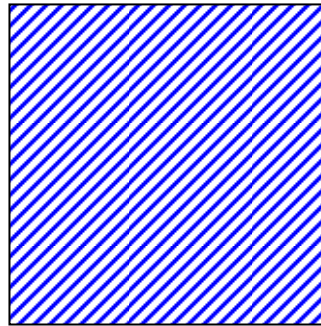

Reduced intensity
by skipping frames
per pixel area

Amplitude Modulation

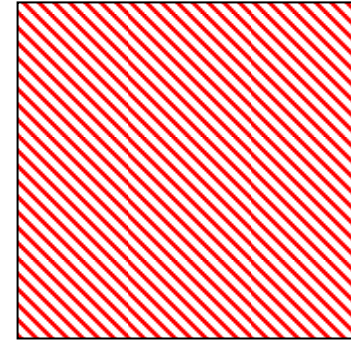

Analog intensity at
full dwell time per
pixel

Grey Scale Generation

(Spatial Modulation / Frame Rate Control)

Dithering

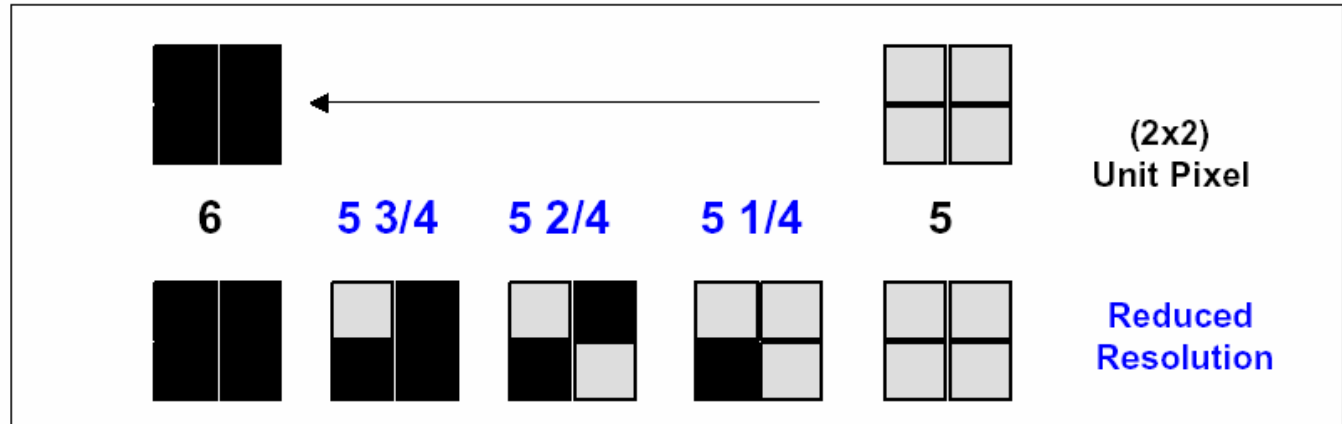

Frame Rate Control (FRC)

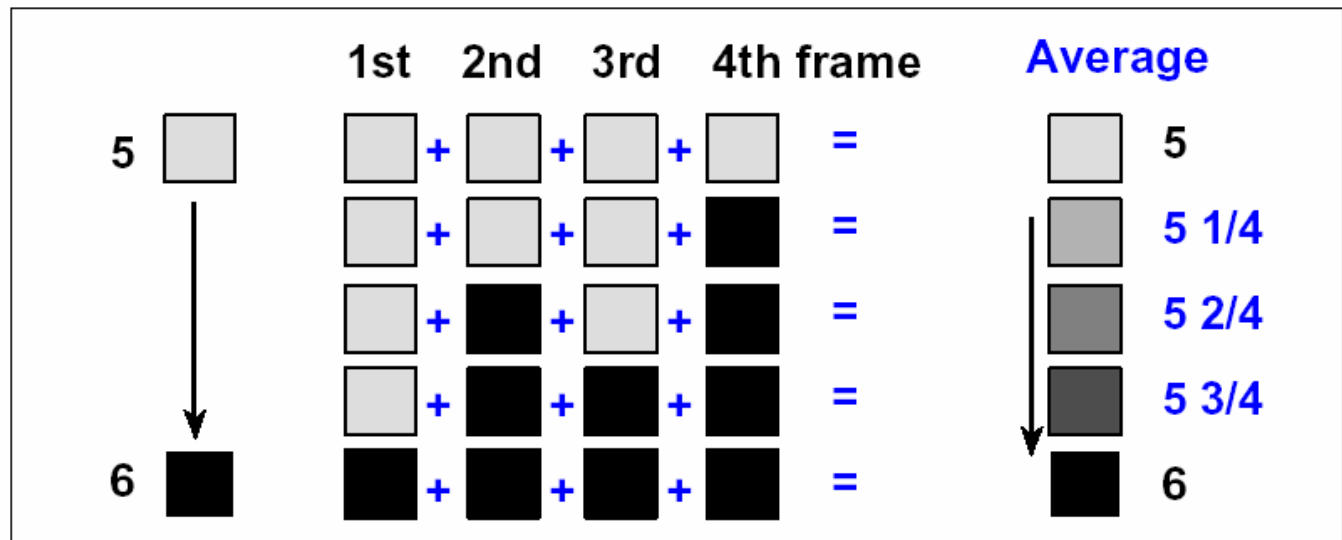

Kim, SID 2001

Grey Scale Generation

(Amplitude Modulation)

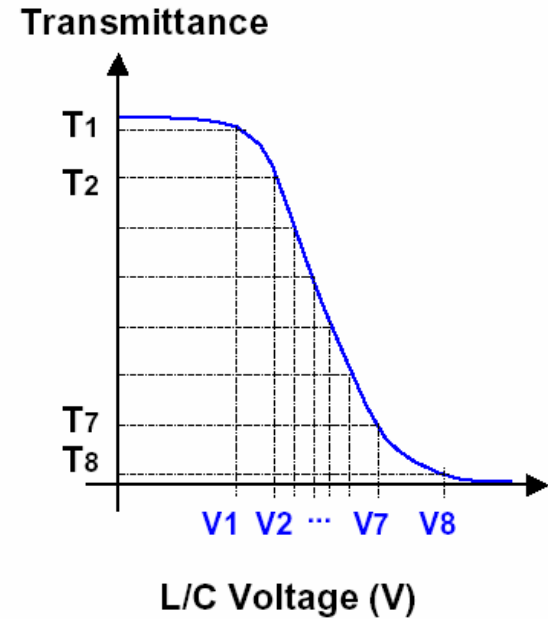
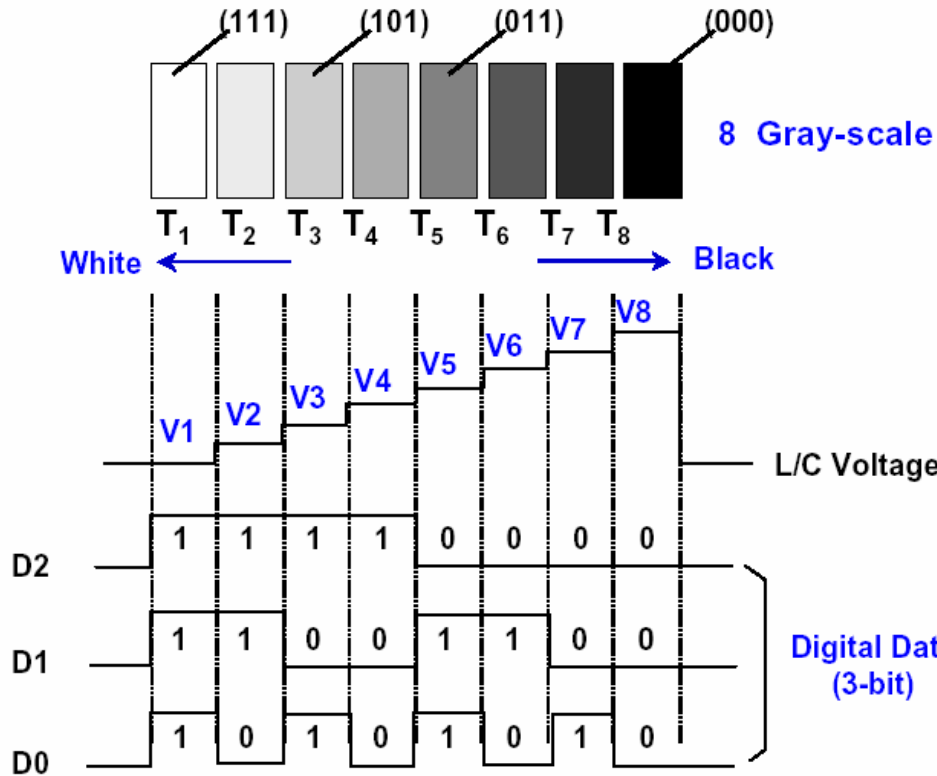

$2^3 = 8 \text{ gray scales}$

Color Generation Techniques

Spatial Color

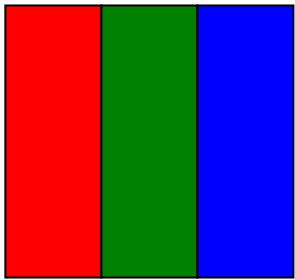

Three selectable color areas per pixel area per dwell time at three times intensity

Sequential Color

One broadband emitter per pixel area addressed three times per dwell time at three times the intensity.

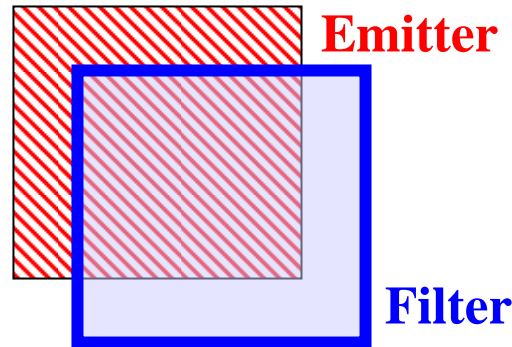

Electronic filter changed three times per dwell time.

Coincident Color

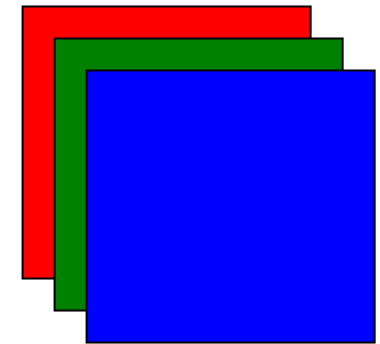

Three selectable transparent color areas per pixel area per dwell time at one times intensity

- Dwell time is allotted for each pixel operation
- Pixel area is total area allotted for spatial information

Driver Circuits

Row
Driver
Circuits

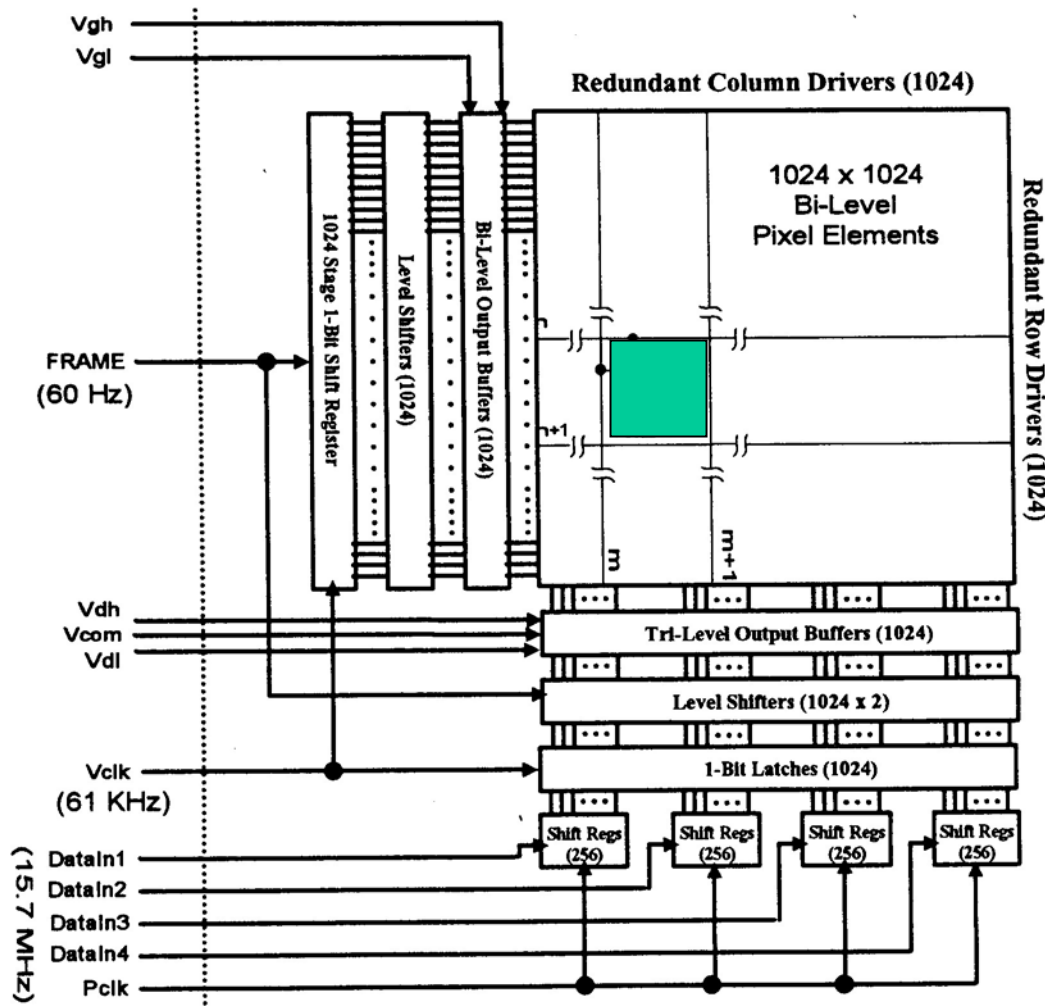

Display
Pixel
Array

Column
Driver
Circuits

Row Driver Circuits

- Shift Registers
 - N stage shift registers
 - Static vs Dynamic
- Level shifters
 - Match outside signal to signal on display
- Output buffers
 - Typically bi-level

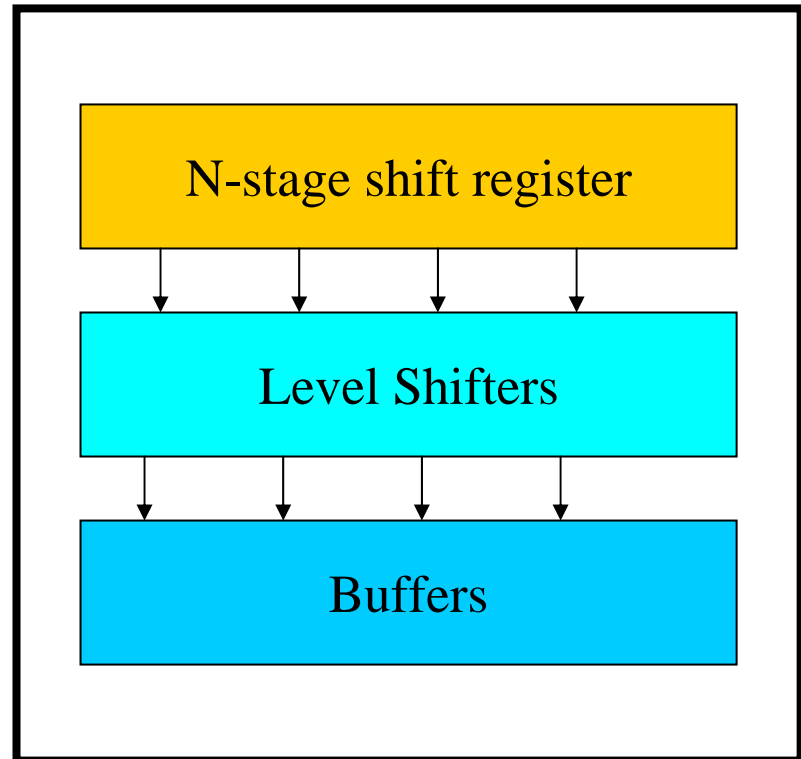

Column Driver Circuits

- Shift Registers
 - N stage shift registers
 - Static vs Dynamic
- Level shifters
 - Match outside signal to signal on display
- Output buffers
 - Typically bi-level

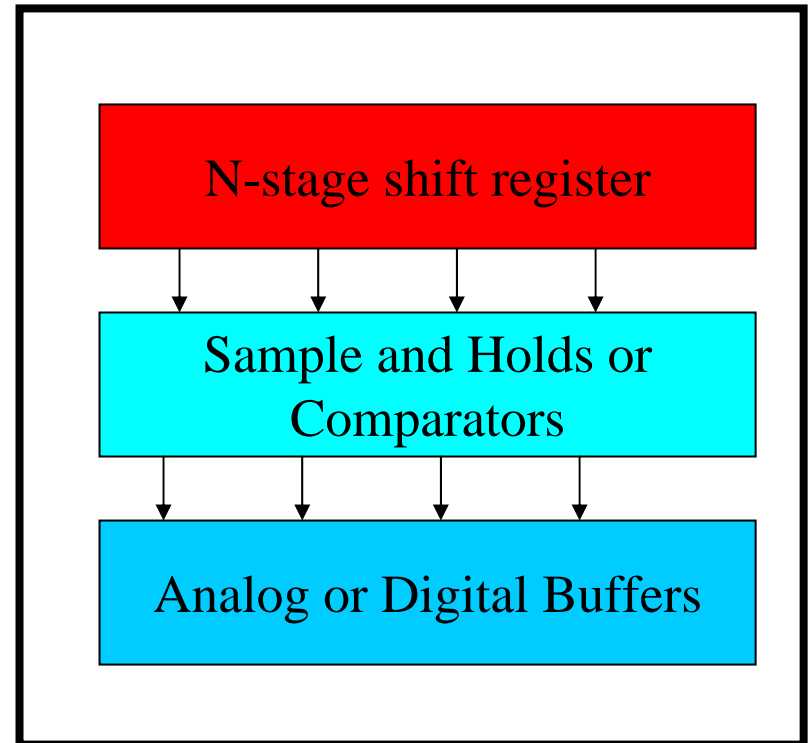

Analog Data Driver

Point at a time

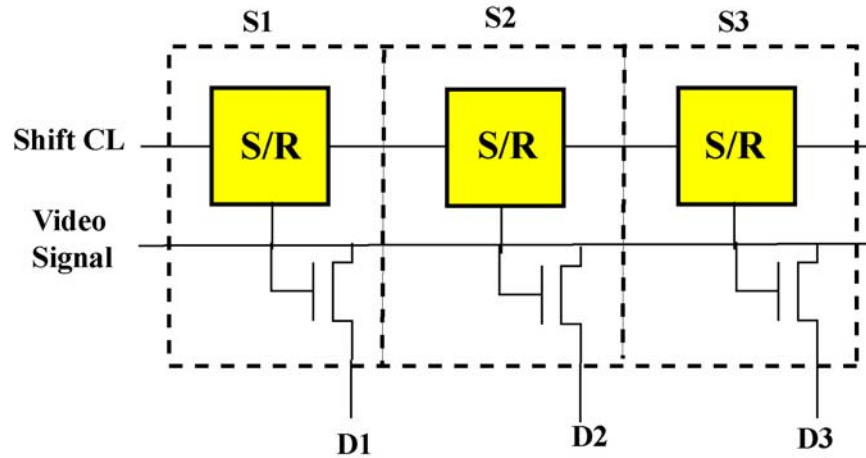

Shift Registers

Line at a time

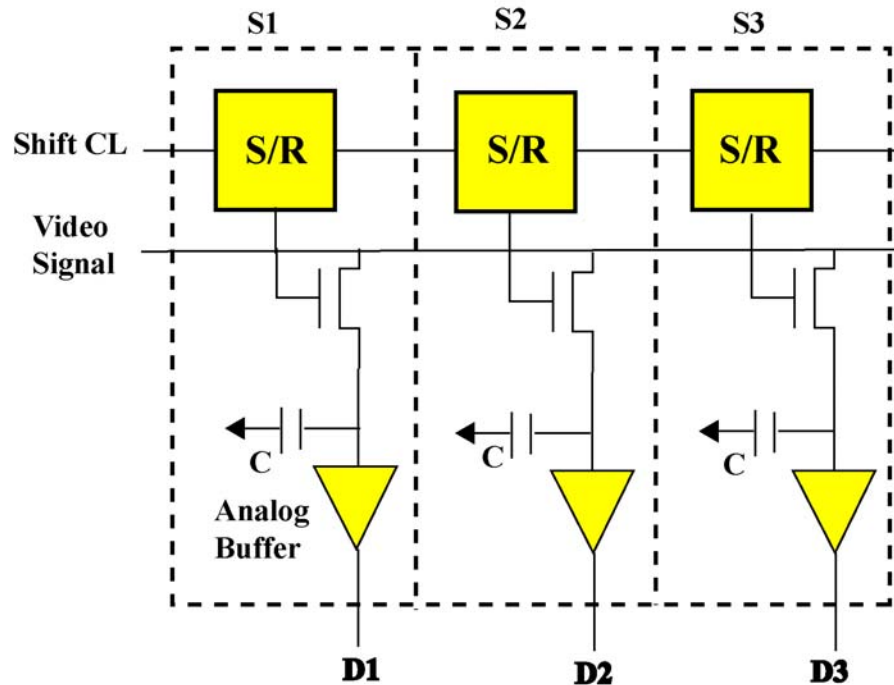

Shift Registers

Morozumi, SID 00
Seminar Notes

Digital Data Drivers

